

United States  
Department of  
Agriculture

**Forest Service**

Forest  
Products  
Laboratory

State and  
Private  
Forestry

General  
Technical  
Report  
FPL-IMP-GTR-3



# Quality Drying in a Hardwood Lumber Predryer Guidebook—Checklist

Eugene M. Wengert  
R. Sidney Boone

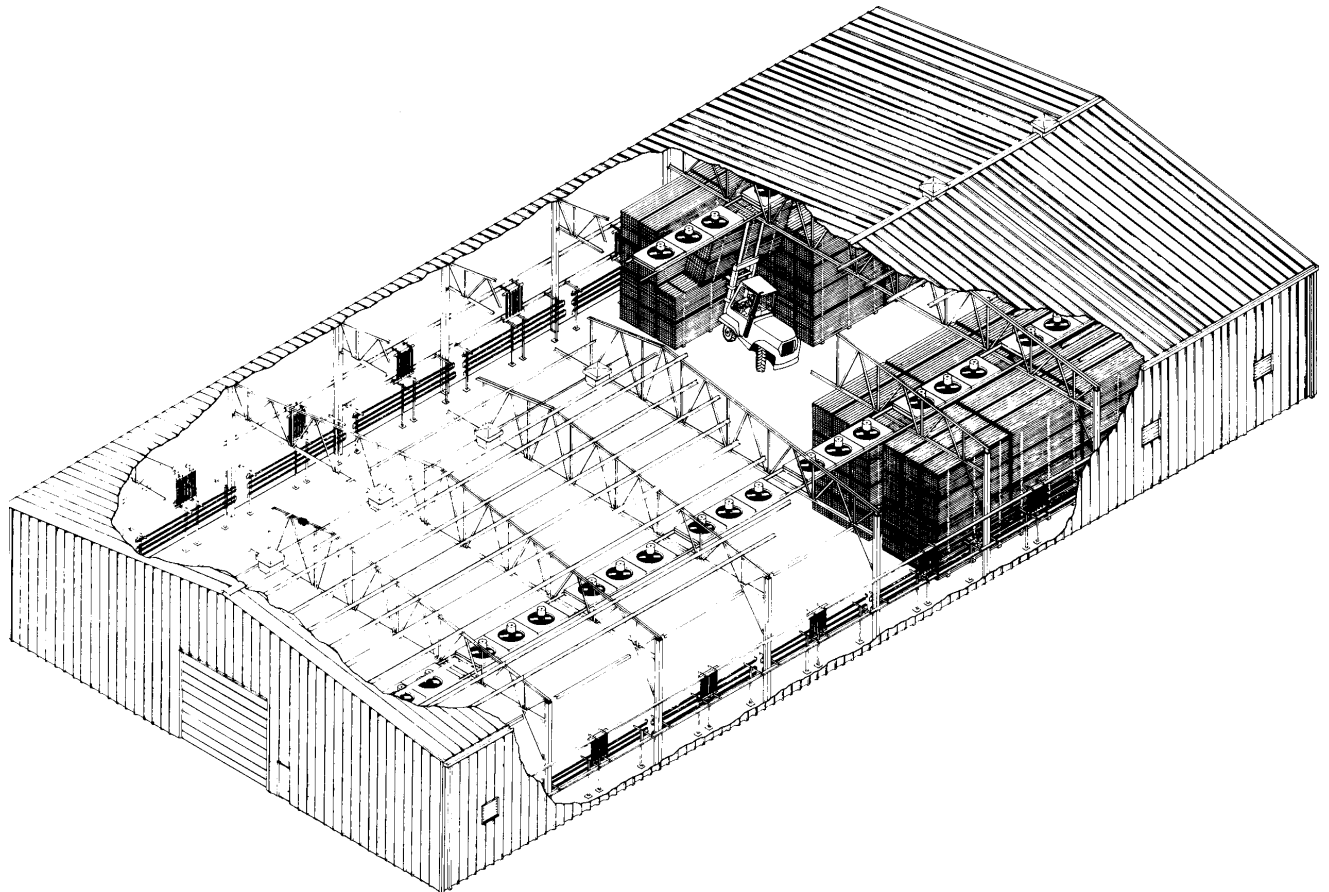

**Lumber Drying Program**

## Abstract

The IMPROVE Lumber Drying Program is intended to increase awareness of the lumber drying system as a critical component in the manufacture of quality lumber. One objective of the program is to provide easy-to-use tools that a kiln/predryer operator can use to maintain an efficient drying operation and therefore improve lumber drying quality. This report is one component of the IMPROVE Program. It is a guidebook–checklist for quality drying in a hardwood lumber predryer that kiln/predryer operators or owners can use to readily evaluate how well their operations rate on those factors that most strongly affect drying quality, with particular emphasis on predryer operation and maintenance and lumber handling. Appendix 1 contains a shortened version of the checklist for easy duplication and filing. Appendix 2 contains the same checklist items; however, the information is arranged by drying system components for convenience in checking individual components.

September 1993

---

Wengert, Eugene M.; Boone, R. Sidney. 1993. Quality Drying in a Hardwood Lumber Predryer: Guidebook–Checklist.

Gen. Tech. Rep. FPL–IMP–GTR–3. Madison, WI: U.S. Department of Agriculture, Forest Service, Forest Products Laboratory. 32 p.

A limited number of free copies of this publication are available to the public from the Forest Products Laboratory, One Gifford Pinchot Drive, Madison, WI 53705–2398. Laboratory publications are sent to more than 1,000 libraries in the United States and elsewhere.

The policy of the United States Department of Agriculture Forest Service prohibits discrimination on the basis of race, color, national origin, age, religion, sex, or disability, familial status, or political affiliation. Persons believing they have been discriminated against in any Forest Service related activity should write to Chief, Forest Service, USDA, P.O. Box 96090, Washington, DC 20090–6090.

## Contents

	<i>Page</i>
Introduction .....	1
Guidebook–Checklist .....	1
Rating System .....	2
Safety Considerations .....	2
Guidebook for Quality Drying in a Hardwood Lumber Predryer .....	3
Standard Operating Practices .....	3
Control Room .....	8
Lumber Stacking and Loading of Predryer .....	9
Operational Checks .....	12
Monitoring Drying Rate and Degrade Formation .....	17
Checklist for Quality Drying in a Hardwood Lumber Predryer .....	19
Standard Operating Practices .....	19
Control Room .....	22
Lumber Stacking and Loading of Predryer .....	22
Operational Checks .....	23
Monitoring Drying Rate and Degrade Formation .....	26
Appendix 1—Summary Checklist for Quality Drying in a Hardwood Lumber Predryer .....	27
Appendix 2—Checklist Arranged by Drying System Components .....	30

# Quality Drying in a Hardwood Lumber Predryer

## Guidebook–Checklist

**Eugene M. Wengert**, Extension Specialist, Wood Processing, Department of Forestry  
University of Wisconsin, Madison, Wisconsin

**R. Sidney Boone**, Research Forest Products Technologist  
Forest Products Laboratory, Madison, Wisconsin

### Introduction

The IMPROVE Lumber Drying Program is intended to increase awareness of the lumber drying system as a critical component in the manufacture of quality lumber. The goals of the program are to help sawmill, furniture, flooring, moulding, and cabinet plant personnel improve lumber quality by identifying sources of drying losses, both grade and volume. Operation of the predryer is only one factor, but often is the most critical factor, that determines lumber drying quality. Each step of the lumber manufacturing process affects lumber drying quality—from the time logs are felled in the woods until the lumber leaves the unstacker after drying. The IMPROVE Lumber Drying Program is designed to systematically evaluate the drying operation and identify areas contributing to poor lumber product quality, both in the drying operation stage and at every prior stage of lumber manufacture. A companion report to this one, *Quality Drying of Hardwood Lumber*,<sup>1</sup> presents a checklist for air- and kiln-drying hardwood lumber. Causes of drying quality losses can be corrected at their source, rather than trying to compensate for them in the kiln.

One objective of the IMPROVE Lumber Drying Program is to provide easy-to-use tools that a kiln operator can use routinely in daily work around the kilns and predryer without having to perform special studies or interfering with production. To help fulfill this objective, this report contains a complete guidebook–checklist for predrying quality hardwood lumber. The guidebook explains the importance of each item on the checklist and describes how to evaluate it. If questions arise

while using the checklist, you can refer to the guidebook for a detailed explanation. The guidebook also provides a quick reference on drying quality. Predryer operators can use the checklist to readily evaluate how well their operations rate on those factors that most strongly affect drying quality. Particular emphasis is given to the operation of the predryer as well as maintenance and lumber handling. In addition to the guidebook and checklist, Appendix 1 contains a summary checklist for easy duplication and filing. Appendix 2 contains the same checklist items but listed according to drying system components for convenience in checking individual components.

### Guidebook–Checklist

Predryers are low temperature dryers that are used to reduce the moisture content of lumber from the green or near green condition to approximately 25%. Because the objective of drying is to ensure a good product at minimum cost and because almost all degrade in drying is initiated in Stage I drying (from green to 2/3 green moisture content), the predryer determines and controls drying quality. The basics of lumber drying reveal that quality in drying is largely a function of three environmental variables: temperature, humidity (or wet-bulb temperature or equilibrium moisture content), and air velocity. Lumber stacking practices also play an important role in quality drying, both in controlling warp and the three environmental variables.

The guidebook–checklist is intended to be used with either steam-heated or dehumidification predryers. It is not our intent to cover all the detailed components or operating techniques of the lumber drying system. We encourage you to use the guidebook–checklist and adapt them to your individual situations. Many other maintenance and operating factors are also important, but these do not have as direct a bearing on drying quality, although they should not be neglected.

<sup>1</sup>Boone, R. Sidney; Milota, Michael R.; Danielson, Jeanne D.; Huber, Dean W. 1991. *Quality Drying of Hardwood Lumber: Guidebook–Checklist*. Gen. Tech. Rep. FPL–IMP–GTR–2. Madison, WI: U.S. Department of Agriculture, Forest Service, Forest Products Laboratory. 56 p.

Chapter 4 of the *Dry Kiln Operator's Manual (DKOM)*<sup>2</sup> contains maintenance checklists and discusses many factors of kiln maintenance. Equipment manufacturers can also supply maintenance checklists and additional information.

The checklist is a working tool and to get the most value from it, you must physically examine various equipment and systems around the predryer. Only by observing the items listed on the checklist can you accurately assess your predryer operation.

For convenience in checking individual systems, such as air circulation or heating, a summary of the checklist items arranged by drying system components is given in Appendix 2.

## Rating System

Each item on the checklist has a rating key based on a scale from 4 (high) to 1 (low). Each level of rating is further described in the guidebook. The high rating of 4 is intended to be attainable, but challenging, for most of the industry. The low score of 1 indicates a strong need for improvement. In a well-maintained and well-operated predryer, most ratings should be 4 and 3.

## Safety Considerations

First and foremost, a predryer must be operated safely. Several important safety criteria are listed below. Common sense must prevail.

### Operator

- Hard hats must be worn when in the predryer. Falling lumber is a significant risk and danger.
- Safety glasses with side shields should be worn to protect against wind blown dust and debris.

## Work Area

- Access doors must open easily and open outward. Exit signs or battery-powered lighting devices are essential in case of electrical failure. There must be at least two exits. Access doors must have a panic bar opening system on the inside rather than a door knob.
- Main loading doors must be equipped with a safety system so that if the door strikes an object when closing, the door will automatically stop and then reopen. These doors must also have a manual release and manual operating system.
- Lighting should be adequate in work areas.
- Water on the floor, especially when the floor is dirty or the concrete is polished, can result in very slippery conditions. Keep floors clean and minimize water on the floor. Remove water from the floor with a squeegee.
- Ice build-up around the doors should be sanded or salted.
- Lock out the fans at the electrical supply panel when it is necessary to work on or near the fans. Each repair person should have his/her own lock.

## Forklift

- Lift truck exhaust from gasoline or diesel engines can be dangerous. Always keep main loading doors open and possibly run exhaust fans when the forklift is in the predryer. Avoid excessive idling of the forklift in the predryer.
- A working audible backup alarm is a must.
- When the main loading door has plastic drive-through strips, the forklift must sound a horn when entering or exiting building.
- If blind areas are present when exiting predryers, install mirrors to assist forklift operator in a safe exit.

---

<sup>2</sup>U.S. Department of Agriculture, Forest Service. 1991. *Dry kiln operator's manual*. Agric. Handb. 188. Washington, DC: U.S. Department of Agriculture, Forest Service. 274 p.

# Guidebook for Quality Drying in a Hardwood Lumber Predryer

For each item in the checklist, the following descriptions summarize how that item affects drying quality and why it is important. Additional descriptions are provided in the *Dry Kiln Operator's Manual* (DKOM)<sup>2</sup> and the companion publication *Quality Drying of Hardwood Lumber: Guidebook–Checklist*.<sup>1</sup>

## Standard Operating Practices

### 1. Maintenance and Inspection

#### 1a. Proper location of dry-bulb sensors

The dry-bulb sensor should be located so it measures the temperature of the air that enters the load. In many downdraft predryers, if the sensor is too close to the wall, it will measure the temperature of the heated air; if too far from the wall, it will measure the temperature of the cooler return air. The correct temperature to measure is a blend of both.

##### Rating

- 4 - Dry-bulb sensors located in the entering air stream
- 3 - Dry-bulb sensors located near the circulating fans
- 2 - Dry-bulb sensors located more than 3 ft from the fans and not in the entering air stream
- 1 - Dry-bulb sensors located close to the wall or roof

#### 1b. Influence of side vents on recorded dry-bulb temperatures

Recorded and measured temperatures should not be affected by the side vents being open or closed. Likewise, the section of a dryer facing the prevailing wind direction should not be cooler than the remainder of the dryer.

##### Rating

- 4 - The dry-bulb sensor located on the west or north side of dryer is within 1°F of dry-bulb temperatures on the east or south side most of the time
- 2 - The dry-bulb sensor located on the west or north side of dryer is more than 1°F lower than the dry-bulb temperatures on the east or south side most of the time

#### 1c. Proper location of the relative humidity (RH) sensor

The RH sensor should be located so it measures the RH of the air that enters the load. In many down-draft predryers, if the sensor is too close to the wall, it will measure the RH of the heated air; if too far from the wall, it will measure the RH of the cooler return air. The correct RH to measure is a blend of both.

##### Ratings

- 4 - RH sensors located in the entering air stream
- 3 - RH sensors located near the circulating fans
- 2 - RH sensors located more than 3 ft from the fans and not in the entering air stream
- 1 - RH sensors located close to the wall or roof

#### 1d. Influence of side vents on recorded RH values

Recorded and measured RH values should not be affected by the side vents being opened or closed. Likewise, the section of the dryer facing the prevailing wind direction should not be drier or wetter than the remainder of the dryer.

Rating

- 4 - The RH on the west or north side should be within 2% RH of the RH on the east or south side most of the time
- 2 - The RH on the west or north side is frequently more than 2% RH higher than the RH on the east or south side

1e. Use of wet-bulbs to determine RH values

The use of a wet-bulb thermometer is common in dry kilns and in many predryers to determine RH. As in a dry kiln situation, if the wet-bulb wick is not clean, it will not give the true wet-bulb temperature. The dirt can be from dust, sawdust, or salts and minerals in the water. For best wet-bulb control, the wick should be replaced weekly; the water to the pan must be clean, plentiful (but not excessive), and about 80°F. The velocity across the wick should be about 600 fpm—usually in a predryer an auxiliary fan blowing across the bulb is required to achieve this velocity.

Rating

- 4 - Wick changed weekly, water is clean, about 80°F, and air velocity across wick is about 600 fpm
- 3 - Wick changed weekly, water is clean, about 80°F, and air velocity across wick is under 400 fpm
- 2 - Wick changed weekly, water is clean, about 80°F, and air velocity across wick is under 200 fpm
- 1 - Wick is changed less than once per week

1f. Use of EMC sensor to determine humidity in predryer

In some predryer control systems, equilibrium moisture content (EMC) is estimated based on electric resistance measurements across a small cellulose pad (EMC wafer). The pad is held by electrodes mounted in the predryer. Like the wet-bulb wick, the cellulose wafer or pad becomes dirty and must be changed at specified intervals for the EMC measurements to be accurate. For best performance and accurate readings, we suggest changing the wafer weekly. Variations in calibration should be less than  $\pm 1/2\%$  EMC.

Rating

- 4 - EMC wafer is changed weekly; calibration is confirmed monthly
- 3 - EMC wafer is changed weekly; calibration is rarely checked
- 2 - EMC wafer is changed less than once a week; calibration is confirmed monthly
- 1 - EMC wafer is rarely checked

1g. Air supply to control instruments and operating valves checked at regular intervals

Compressed air is used to operate many predryer controllers and valves. Many pneumatic controller problems can be traced to dirt or moisture in the air supply. Water must be drained from the compressor daily. Automatic draining is preferred.

Rating

- 4 - Air compressor is checked and drained daily
- 3 - Air compressor is inspected on some other schedule but at least monthly
- 2 - Air compressor is inspected only when a problem is suspected
- 1 - Air compressor is inspected only when the controller or air supply does not work

1h. Drip pans positioned below roof vents

Because of the comparatively high relative humidities maintained in predryers, water may condense on or near the roof vents. Drip pans should be positioned about 4 feet below each roof vent to catch the condensation rather than allowing it to drip onto the floor or possibly the lumber.

Rating

- 4 - Drip pans are positioned below all roof vents and are of sufficient capacity to retain all condensate or have drains provided
- 2 - No drip pans present

1i. Condensation of water on predryer floor

Condensation of water on the floor of the predryer must not occur. Water on the floor presents a safety problem and problems in maintaining appropriate RH setpoints. Condensation will occur whenever the surface temperature of the floor is below the dewpoint. Perimeter foundation insulation is suggested to avoid cold floors.

Rating

- 4 - Condensation on the floor is rarely or never seen
- 3 - On the coldest days, a little condensation may be seen
- 2 - Occasionally a little condensation may be seen
- 1 - Wet spots are frequently seen

1j. Removal of dirt and debris from predryer floor

Over time, considerable dirt and mud will be tracked into the dryer by the forklift or other vehicles and appreciable amounts of sawdust, bark, and dirt will collect on the floor. This should be cleaned at least weekly to avoid increasing the risk of ambrosia beetle infestation and to keep dust off the lumber.

Rating

- 4 - Floor cleaned weekly
- 3 - Floor cleaned once per month
- 2 - Floor cleaned two times a year
- 1 - Floor never cleaned

1k. Roof is free of leaks

Leaking roofs allow water to drip on the lumber or on the floor, both undesirable. Roofs should be inspected for leaks and any needed repairs made.

Rating

- 4 - No leaks seen
- 2 - Roof leaks on days with heavy rains
- 1 - Roof leaks frequently

1l. Traps checked for proper operation and plumbed for ease of checking

Traps are vital in separating condensed water from the steam in the heating system. Traps should be sized large enough to handle the peak load. Even a properly designed and installed trap can malfunction due to dirt. Installing screens just upstream of the traps and flushing traps every 30 days can help prevent malfunctions.

If condensate is not removed from the heating coils, they will fill with condensed water, keeping steam from entering. To ensure even heating throughout the predryer, the traps should be checked frequently. Good predryer design calls for placing traps where they are readily accessible (but as close to the coils as practical) for ease of checking while the predryer is running.

Rating

- 4 - Each bank of coils has its own trap and check valve
- 3 - Each main heat coil is trapped, but side vent heaters are not individually trapped
- 1 - Several banks of coils use one trap or check valves not installed

1m. Circulation fans turning in proper direction and lubricated properly

Uniformity of airflow is one major concern of predryer operation. Critical attention should be paid to observing that each fan is turning in the proper direction to direct the airflow down through the load. It is not that uncommon when replacing a fan motor to reverse the wiring, resulting in the fan turning the opposite direction than desired. Fan motors and assemblies must be lubricated as frequently as recommended by the manufacturers.

Rating

- 4 - All fan motors turn the same direction and are lubricated at manufacturers specified intervals
- 3 - All fan motors turn the same direction, but are NOT lubricated at manufacturers specified intervals
- 2 - Fans seldom checked to see if all running and turning in same direction
- 1 - Fans not checked and are lubricated only when problem occurs

1n. Exhaust fans turning for proper airflow and lids closing properly

Each exhaust fan must turn in the proper direction so that fans exhaust the moist air when required. Exhaust fan lids should open and close properly.

Rating

- 4 - Exhaust fans and lids are checked monthly, lubricated as needed
- 2 - Exhaust fans and lids are not checked monthly and/or not lubricated

1o. Proper functioning of side vents

The purpose of the side intake vents is to bring in outside make-up air to help control the relative humidity in the predryer. The vents are sometimes equipped with movable louvers. These louvers should be capable of opening fully or closing fully, as required.

Rating

- 4 - Proper operation of side vents checked weekly
- 3 - Proper operation of side vents checked monthly
- 2 - Proper operation of side vents checked semi-annually
- 1 - Proper operation of side vents checked only when problems occur

1p. General building inspection: corrosion, insulation, joints

A general inspection should be made of the building, looking for occurrences of corrosion, condensation, and insulation problems. A comprehensive detailed inspection should be made annually, with a brief inspection conducted monthly. Failure to identify and resolve problems with the building early can lead to added expense later.

Rating

- 4 - Thorough check and report provided to management every 6 weeks
- 3 - Thorough check and report provided to management every 3 months
- 2 - Inspection and report provided annually
- 1 - Not inspected; no report prepared



1q. Heating coils clean and free of debris

Air must pass between the fins of the fin pipe to transfer energy from the coil to the air. If the spaces between the fins are obstructed or fins are covered with rust, dirt, or debris, the surface area available for heat transfer is greatly reduced. Boards, scrap lumber, plywood, pallets, or other materials should not be allowed to collect near the heating coils and restrict air flow around the coils.

Rating

- 4 - Coils clean and free of obstructions
- 3 - Coils fairly clean (slight rust) and free of obstructions
- 1 - Coils with heavy rust; coils blocked with debris

**2. Moisture Content Monitoring and Recordkeeping**

2a. Knowledge of history of lumber before going into predryer

Knowing the history of the lumber to be dried in your predryer is important. The lumber may have been purchased through a broker or directly from the sawmill. With woods prone to surface checking (oak and beech) and those prone to stain (maple, hackberry, gum), it is quite helpful to know what has happened to the lumber since it was sawn. How long was it solid piled before being put on stickers? Was it trucked a considerable distance untarped? Was it rained on? Is there or has there been ice and/or snow on the lumber? If you suspect that the lumber you expect to load into your predryer came from several sources or some packages are drier than others, choose your sample boards to give you a representative sample of moisture content (MC) variation. Through use of sample boards, know what the moisture content of the lumber is at time of loading predryer.

Rating

- 4 - History of the lumber and the MC of the lumber going into the predryer are known
- 3 - You can reconstruct the history and have taken a few moisture readings
- 1 - No effort was made to learn the history or to determine the MC

2b. Use of sample boards (kiln samples) to monitor moisture content

Using sample boards (kiln samples) to monitor the changing MC in a charge of lumber during drying has traditionally been considered the preferred method for drying hardwoods. This technique, using short, carefully chosen boards placed at selected locations, especially on the entering air side of the pile, is a dependable method for monitoring MC as drying proceeds. Approximately one sample per 10 to 15 thousand board feet is the suggested minimum. More samples will be needed when the resource varies—mixed thicknesses, mixed species, varying initial MC, lowland oak included, and so on.

Rating

- 4 - Sample boards are always selected, prepared, placed, and used as recommended in Chapter 6 of the DKOM
- 3 - Sample boards are usually used, with minimal attention to selection and usually only two or three boards used per 100,000 board feet
- 2 - Sample boards are rarely used
- 1 - Sample boards are never used

2c. Disposition of lumber after removal from predryer

After the lumber has reached the desired target moisture content, it should be moved directly to the dry kiln to complete the drying or to covered storage.

Rating

- 4 - Lumber always goes directly to the kiln
- 3 - Lumber always goes to kiln or to unheated covered storage building

- 2 - Lumber usually goes to kiln or to unheated storage building
- 1 - Lumber usually goes to unprotected storage

2d. Identification of packages of lumber in predryer

Each package of lumber should be numbered or coded and notation made of initial MC, date of placement and location in predryer. Date of removal and disposition following predrying should also be noted. This will provide records to assist in tracing problems and monitoring progress of drying.

Rating

- 4 - Individual packages are monitored
- 3 - Entire or partial kiln loads are monitored as a group
- 1 - No records are regularly maintained

### **3. Learning Opportunities**

3a. Opportunities to visit other sites and meet other operators

Meeting with other predryer operators and visiting their operations provides a chance to discuss common problems and learn how others may do things differently.

Rating

- 4 - Visit other predryer sites three or more times per year
- 3 - Visit other predryer sites twice a year
- 2 - Visit other predryer sites once a year
- 1 - Never visit other predryer sites

3b. Attend dry kiln association meetings and drying workshops

Dry kiln association meetings and drying workshops are one of the best sources of up-to-date information on the latest equipment. Attending them also gives you a chance to meet other operators and equipment suppliers and to learn more about their approaches to similar situations.

Rating

- 4 - Attend dry kiln association meetings yearly and have attended at least one workshop
- 3 - Regularly attend meetings but have never been to a workshop
- 2 - Attend meetings every 2 or 3 years
- 1 - Never attend meetings or workshops

## **Control Room**

### **4. Environmental Conditions in Control Room Appropriate**

4a. Temperature and relative humidity controlled for good working conditions of personnel and control instrumentation

The temperature and the relative humidity in the control room should be controlled to maintain comfortable working conditions for personnel and to ensure reliable working of the various recording and control instruments housed in the control room.

Rating

- 4 - Control room is always well heated and air conditioned
- 3 - Control room is well heated and air conditioned on most days
- 1 - Temperature and relative humidities in control room considered not important

## **5. Instrument Charts**

### 5a. Correct instrument charts are used

To assure proper calibration and operation, it is very important that the paper charts on the recorder are correct for the model. All recorders do not have the same temperature range and the spacing between lines on the chart may be different. Check the manufacturer's information and compare this to the charts.

#### Rating

4 - Chart paper matches recording instrument

1 - Wrong chart paper is used

### 5b. Chart record is clear and legible

Charts for most instruments are arranged on a 1-week (7-day) cycle. The chart should be changed every week so that recording is clear, sharp, and legible. Charts that have cycled for 2 or more weeks are of little use because of overwriting and illegibility. Ensure that pens are properly inked and leave a clear, sharp line.

#### Rating

4 - Charts are changed weekly with clear legible tracings

1 - Charts are changed infrequently, overwritten, provide no useful recording of conditions

## **Lumber Stacking and Loading of Predryer**

### **6. Sticker and Bolster Thickness**

#### 6a. Sticker thickness uniformity

Stickers are usually 5/8 to 1 in. thick. Regardless of size or thickness, all stickers within a predryer charge should be surfaced to a uniform thickness. Variation in sticker thickness can cause nonuniformity of drying, and if variation is large enough, can contribute to kink or other forms of warp. Stickers that are too thick should be resurfaced, and if they are too thin, broken, or warped, they should be discarded.

Measure and record the thickness near the center of 20 stickers. Because stickers tend to compress after a few uses, try to measure those stickers that are currently in use, selecting them either at the stacker or the unstacker. Use a dial caliper or micrometer for the measurements, if possible.

Subtract the smallest of the 20 measurements from the largest. This gives a value called the range. It is a measure of the sticker thickness variation.

#### Rating

4 - Range of sticker thickness is 1/32 in. (0.031 in.) or less

3 - Range of sticker thickness is 1/16 in. (0.063 in.) or less

2 - Range of sticker thickness is 1/8 in. (0.125 in.) or less

1 - Range of sticker thickness is greater than 1/8 in. (0.125 in.)

#### 6b. Bolster thickness uniformity

Different bolster thickness can cause warp and kink in boards as they bend over the bolster. Also, two different bolster thicknesses under side-by-side packages can raise one package enough so that the sticker spaces are no longer aligned. This can block horizontal airflow through the packages. If the bolsters are not square, make sure they are positioned so the bolster space is the same thickness for all packages.

Measure and record the thickness of 20 bolsters. Bolsters tend to become compressed the first few times in use and damaged from dropping and being hit by forklift tines. Try to use bolsters that have been used

several times as well as some that have only been used a few times so they represent the typical mix of bolsters. Measure more than 3 in. from the end of the bolster to avoid thin spots where the ends are broken or compressed.

Write down the 20 measurements and subtract the smallest from the largest to get the range of thicknesses.

#### Rating

- 4 - Range of bolster thickness is 1/8 in. (0.125 in.) or less
- 3 - Range of bolster thickness is 1/4 in. (0.250 in.) or less
- 2 - Range of bolster thickness is 3/8 in. (0.375 in.) or less
- 1 - Range of bolster thickness is greater than 3/8 in. (0.375 in.)

#### 6c. Uniformity of sticker straightness

In hardwood plants using semiautomatic stackers and stickers up to 7 or 8 ft in length, it is likely that a significant number of stickers will develop a noticeable amount of crook and/or kink after repeated use. Stickers with more than 3 in. of crook or side kink (usually resulting from abnormal shrinkage around or near a knot), as measured by an imaginary line drawn from one end to the other, should not be used. If the plant also uses shorter stickers in other stackers, predryers, or kilns, excessively crooked or kinked stickers can be cut back to shorter lengths and utilized. If not, they should be discarded. Stickers with broken ends that are shorter than the width of the package by 3 in. or more should not be used.

Measure and record the departure from straightness of about 20 stickers having noticeable amounts of crook or kink.

#### Rating

- 4 - All stickers have less than 2 in. of crook or kink
- 3 - No more than 3 of 20 stickers have 2 in. or more of crook or kink
- 2 - No more than 5 of 20 stickers have 2 in. or more of crook or kink
- 1 - More than 5 of 20 stickers have 2 in. or more of crook or kink

#### 6d. Lumber thickness variation

Some variation in lumber thickness is to be expected from normal sawing conditions. However, thickness variation greater than about 1/32 in. (0.031 in.) is usually a result of sawblade or feed problems in the sawmill. Thickness variation greater than this can have a major effect on predryer/kiln drying. Thick lumber dries more slowly than thin lumber, so mixing thick and thin lumber in a charge increases MC variation. When thick and thin pieces are mixed across a course, the thinner pieces are not restrained by the stickers. Thin lumber is then free to cup, twist, and bow.

Look at the ends of 15 packages of green lumber. All the boards should appear the same thickness with the stickers straight and touching all boards. Figure 1 illustrates how to evaluate thickness variation.

#### Rating

- 4 - All boards are uniform and touching stickers; stickers are not bent
- 3 - Fewer than 10 boards per package do not touch stickers or stickers bend slightly over thick and thin lumber
- 2 - Thickness variation is sufficient to bend stickers or show gaps more than 1/8 in. wide above boards
- 1 - Thickness variation is great enough to make stacking visibly irregular

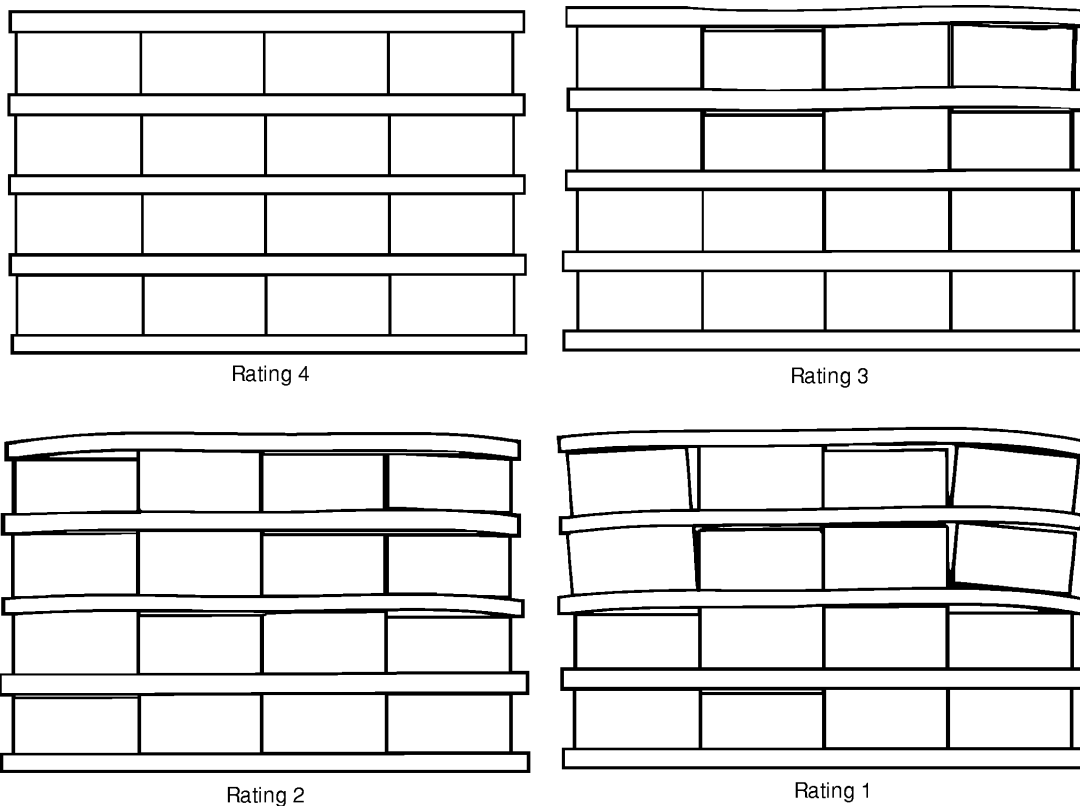

Figure 1. Evaluating lumber thickness variation (end view).

6e. Painted lines on floor help proper positioning of lumber stacks

Easily visible, painted lines or stripes on the floor are necessary to properly position the lumber stacks in the large open bays of the predryer. Otherwise it is difficult for the forklift operator to keep the piles aligned for proper air circulation.

Rating

- 4 - Lines easily seen and properly located
- 2 - Lines obscure or worn away
- 1 - No lines on floor

6f. Plenum width adequate

The placement of the stacks of lumber cannot encroach into the fan plenum area—that is, cannot interfere with the proper air flow from the downdraft fans. Uniform air is a real concern in most predryers and considerable attention must be paid to make airflow as even as possible. Stacks may shift or lean during drying, and the possibility of this occurring must be considered when loading the predryer. Provide adequate room for movement. Plenum width should be no less than about the distance of the total pile height divided by five.

Rating

- 4 - Plenum width (in ft) is at least the total pile height (in ft) divided by 5, and fewer than 1 out of 25 top stacks is slightly in the plenum area
- 3 - Plenum width (in ft) is at least the total pile height (in ft) divided by 5, and fewer than 1 out of 10 top stacks is slightly in the plenum area
- 2 - Fewer than 1 out of 5 top stacks is slightly in the plenum area; plenum width is significantly less than suggested
- 1 - Many stacks are encroaching on the plenum area

## 6g. Spacing between lumber piles

When two or more piles are on each side of the plenum, the suggested spacing between adjacent lumber piles (edge to edge) is 4 in.

### Rating

- 4 - Spacing between adjacent lumber piles is 4 to 5 in., consistently
- 3 - Spacing between adjacent lumber piles is 3 to 8 in., consistently
- 2 - More than 1 out of 4 adjacent piles is closer than 3 in.
- 1 - Spacing is often under 3 in.

## Operational Checks

### 7. Dry-Bulb Temperatures

#### 7a. Appropriate range of operating temperatures

The dry-bulb temperature should typically be between 80°F to 90°F, although a 95°F dry-bulb temperature, or higher, may have to be used if outside temperature is warm and relative humidity (RH) is high. The *absolute* humidity inside the predryer should be 5 grains per cubic foot wetter than outside the predryer. To achieve this difference, increase the dry-bulb temperature in the predryer while keeping the RH unchanged.

### Ratings

- 4 - Dry-bulb temperature is between 80°F to 90°F (85°F to 95°F in summer)
- 2 - Dry-bulb temperature is less than 80°F or more than 90°F

#### 7b. Accuracy of dry-bulb sensors

The dry-bulb temperature indicated on the recorder or readout instrument must be within 1°F of the temperature measured by a dry-bulb thermometer that has 1°F or 1/2°F divisions. A thermometer with only 2°F divisions, commonly used for kiln measurements, is not suitable. Each dry-bulb sensor location must be checked separately. Dry-bulb checks should be made every 3 months. If variation is noted, two additional readings on the next 2 days should be taken to confirm the variation before any recalibration is done. In most predryers, temperatures should be measured under the downdraft fans just before the air enters the stack.

### Rating

- 4 - Dry-bulb temperature is checked every 3 months and is within 1°F of the temperature indicated on the recorder/readout/controller for all sensors
- 3 - Dry-bulb temperature is checked every 3 months and is within 1°F of the temperature indicated on the recorder for 80% of the sensors (2°F on others)
- 2 - Dry-bulb temperature is checked at least every 6 months and is within 2°F of the temperature indicated on the recorder for all sensors
- 1 - Dry-bulb temperature is not checked regularly, or there is a difference of 2°F on one or more sensors

#### 7c. Hourly variation of dry-bulb temperature

The recorded dry-bulb temperature on the chart should be at the desired level and should not vary throughout the day by more than  $\pm 1^\circ\text{F}$ . Any greater variation should (a) be explained and noted on the chart and/or (b) be an indication of needed maintenance. Individual zones should vary no more than 3°F from each other.

### Rating

- 4 - Variation within  $\pm 1/2^\circ\text{F}$  throughout the day
- 3 - Variation within  $\pm 1^\circ\text{F}$  throughout the day
- 2 - Variation within  $\pm 2^\circ\text{F}$  throughout the day
- 1 - Variation more than 2°F throughout the day

#### 7d. Dry-bulb temperature variation within control zone

The dry-bulb temperature within a control zone should not vary from the temperature at the control point more than  $\pm 1^\circ\text{F}$ . This is typically checked by measuring the temperature every 6 to 8 ft along the plenum under the downdraft fans.

##### Rating

- 4 - Variation within  $\pm 1^\circ\text{F}$
- 2 - Variation within  $\pm 2^\circ\text{F}$
- 1 - Variation more than  $\pm 2^\circ\text{F}$

#### 7e. Selecting "controlling" zone dry-bulb temperature for the predryer

The controlling zone dry-bulb sensor should be the one located in the zone with the wettest lumber, except in extenuating circumstances.

##### Rating

- 4 - Controlling bulb/sensor is where the wettest lumber is located
- 1 - Controlling bulb/sensor is NOT where the wettest lumber is located

#### 7f. Possible shut-down of predryer when main door is open

If dry-bulb temperature changes by more than  $2^\circ\text{F}$  when the main door(s) of the predryer are opened, the entire unit should be shut down when the door is open.

##### Rating

- 4 - Fans are turned off when main door is open and dry-bulb temperature changes by  $2^\circ\text{F}$
- 2 - Fans are turned off when main door is open and dry-bulb temperature changes by  $4^\circ\text{F}$
- 1 - Fans always run when main door is open

### **8. Wet-Bulb Temperatures, RH, or EMC**

#### 8a. Accuracy of wet-bulb sensor

The wet-bulb temperature indicated on the recorder or readout instrument must yield a RH in the predryer within  $\pm 2\%$  RH of the value obtained from a sling psychrometer that has thermometers with  $1^\circ\text{F}$  or  $1/2^\circ\text{F}$  divisions. Because of the high speed of readout, a digital hygrometer can be used to indicate %RH. This hygrometer should be checked for accuracy using a  $1^\circ\text{F}$  sling psychrometer every 3 months. Each sensor location should be checked separately. If variation is noted, readings on at least three different days should be noted to confirm the variation before recalibration is done.

##### Rating

- 4 - Wet-bulb sensors are checked every 3 months and are within  $\pm 2\%$  RH
- 3 - Wet-bulb sensors are checked every 3 months and are within  $\pm 4\%$  RH
- 2 - Wet-bulb sensors are checked less frequently than every 3 months and are within  $\pm 2\%$  RH
- 1 - Wet-bulb sensors are rarely checked or are out of calibration

#### 8b. Accuracy of relative humidity or EMC sensor(s)

The relative humidity (RH) indicated on the recorder or readout instrument must be within  $\pm 3\%$  RH of the RH measured by a sling psychrometer that has thermometers with  $1^\circ\text{F}$  or  $1/2^\circ\text{F}$  divisions. A thermometer with only  $2^\circ\text{F}$  divisions, commonly used with kiln measurements, is not suitable. Alternatively, the RH can be measured with a solid state direct RH reading device whose calibration has been verified within the last 3 months. Relative humidity checks should be made once every month. If variation is noted, two additional

readings on the next 2 days should be taken to confirm the variation before any recalibration is done. In most predryers, RH should be measured under the downdraft fans, just before the air enters the stack.

Rating

- 4 - RH sensors are checked monthly and are within  $\pm 2\%$  RH
- 3 - RH sensors are checked monthly and are within  $\pm 4\%$  RH
- 2 - RH sensors are checked less frequently than once a month and are within 2% RH
- 1 - RH sensors are rarely checked or are out of calibration

8c. Daily variation of wet-bulb temperature/RH/EMC

The wet-bulb temperature (RH or EMC) recorded on the chart or indicated on the readout instrument should be at the desired level and should not vary throughout the day by more than  $\pm 1^\circ\text{F}$  ( $\pm 3\%$  RH or  $\pm 1\%$  EMC). Variation(s) greater than this should (a) be explained and noted on the chart and/or (b) be an indication of needed maintenance. Individual zones should vary no more than 5% RH from each other.

Rating

- 4 - Daily variation is within the limits specified
- 2 - Daily variation is within twice the limits specified
- 1 - Daily variation is greater than twice the limits specified

8d. Possible shut-down of fans when main door is open

If the RH in the predryer changes by more than 5% when the main door(s) is opened, the entire unit should be shut down when the door(s) is open.

Rating

- 4 - Fans are turned off when main door is open and RH changes by 5% RH or 1-1/2% EMC
- 2 - Fans are turned off when main door is open and RH changes by 10% RH or 3% EMC
- 1 - Fans always run when main door is open

8e. RH limits in predryer when loading wet lumber

When wet lumber is brought into the predryer, the RH should not exceed the desired value by more than 3% RH. If the predryer is too humid, the incoming lumber should be brought in over a several day interval.

Rating

- 4 - Actual RH exceeds desired value by 3% or less
- 2 - Actual RH exceeds desired value by 3% to 5%
- 1 - Actual RH exceeds desired value by more than 5%

## **9. Fan Operation and Air Velocity**

9a. Fans turning for proper airflow

To dry lumber, air of controlled temperature and humidity must be passed uniformly over the surface of the lumber. This circulating air is the "workhorse" of the predryer or dry kiln. As such, the air performs two tasks: it carries heat to the wood to evaporate the water and it removes the evaporated water vapor. An adequate volume of air must pass uniformly through the courses of lumber to accomplish these two tasks. In the predryer, all fans should be operating, have the same rpm, and have the same blade pitch.



Rating

- 4 - Fans are checked for proper operation (rotation, rpm, pitch) once a year, and all fans are observed each week to determine if all fans are operating
- 3 - Fans are checked for proper operation (see above) once a year, and weekly check indicates all but one fan is operating
- 2 - Fans are checked for proper operation (see above) once a year, and weekly check indicates all but two fans are operating
- 1 - Fans are not checked frequently; only when problems arise

9b. Average air velocity through the load

The air velocity through the load should be measured on the leaving air side of a downdraft predryer in at least 10 locations per bay and the values averaged. The average should be 125 ft/min to assure good uniform drying. This should be checked for every new load of lumber after the predryer is completely loaded.

Rating

- 4 - Air velocity is checked on each load and is 100 to 150 ft/min on the average
- 3 - Air velocity is checked on each load and is 75 to 175 ft/min on the average
- 2 - Air velocity is checked occasionally and is 75 to 175 ft/min on the average
- 1 - Air velocity is rarely checked

9c. Air velocity uniformity/variation

In addition to average velocity of air through the load, the variation around the average is also important. Air velocity through the lumber stacks, as measured on the exit side of the load, should be as uniform as possible. Although some variation is to be expected, an ideal value is  $\pm 25$  ft/min; the maximum suggested variation is  $\pm 50$  ft/min. This uniformity is required vertically (at different height levels in the piles) as well as along the length of the predryer.

Rating

- 4 - Air velocity measurements do not vary by more than  $\pm 25$  ft/min
- 3 - Air velocity measurements do not vary by more than  $\pm 50$  ft/min
- 2 - Air velocity measurements do not vary by more than  $\pm 75$  ft/min
- 1 - Air velocity measurements vary by more than  $\pm 75$  ft/min

9d. Use of baffles in plenum space

Flat baffles should be used in the plenum space of downdraft predryers to assist in obtaining uniform air flow. Two baffles may be required when stacks are more than 18 ft high. If baffles are not used, piles should be reloaded after 2 weeks, with packages reversed top to bottom and bottom to top (Fig. 2).

Rating

- 4 - Plenum baffle always used
- 3 - Plenum baffle usually used
- 1 - Plenum baffle seldom or never used

9e. Use of end baffles

End baffles should be used at the end of the piles that are not within 2 ft of the end of another pile to force air through the piles rather than allowing it to go around.

Rating

- 4 - End baffles always used
- 1 - End baffles NOT used

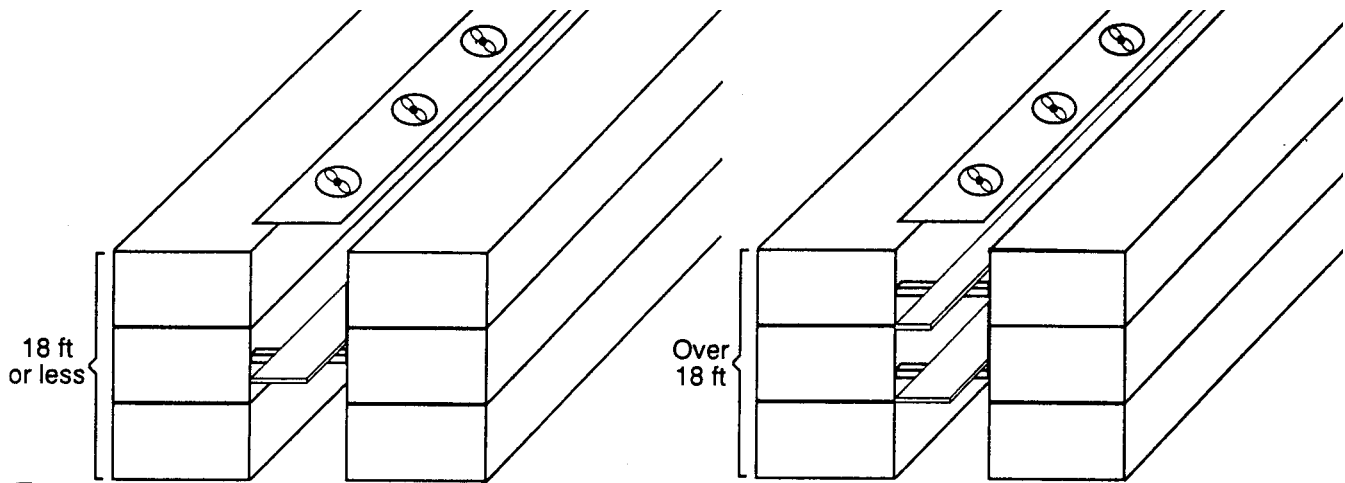

Figure 2. Placement of baffles in plenum space.

#### 9f. Use of tapered bolsters

In a predryer design by Imrie<sup>3</sup>, best performance is obtained by using tapered bolsters. This permits the plenum to be wider at the top than at the floor, by tilting the piles slightly.

Rating

- 4 - Tapered bolsters always used
- 1 - Tapered bolsters NOT used

#### 9g. Burlap wrap for thick lumber

Thick lumber (8/4 and thicker) of refractory species, such as oak and beech, may require wrapping in burlap cloth or plastic "netting fabric" to reduce airflow and rapid drying of the surface that may produce surface checking.

Rating

- 4 - Burlap wrap used as appropriate
- 1 - Burlap wrap rarely or never used

#### 9h. Fan control within a control zone

All predryers should have the fans wired such that all fans in a particular control zone may be turned off if desired. This slows drying of the lumber and avoids increasing RH. The procedure of turning every other fan on or off is not recommended.

Rating

- 4 - Fans in a zone can be turned on/off easily
- 3 - Fans in a zone can be turned on/off with difficulty
- 1 - Fans in a zone cannot be turned on/off independently

<sup>3</sup>The use of trade or firm names in this publication is for reader information and does not imply endorsement by the U.S. Department of Agriculture of any product or service.

## Monitoring Drying Rate and Degradation Formation

### 10a. Use of sample boards to monitor drying rate

The drying rate of the lumber, using properly prepared sample boards (see 2b.), should be checked on a daily basis, especially with greener lumber. Adjustment of conditions in the predryer may be required.

#### Rating

- 4 - Sample boards are used and are checked three times per week
- 3 - Sample boards are used and are checked once a week
- 2 - Sample boards are seldom used
- 1 - Sample boards are never used

### 10b. Monitoring for presence of surface checking on incoming lumber

Incoming oak and beech lumber that is not green-from-the-saw should be checked for the presence of existing surface checks before or as it is being loaded in the predryer. This can be done by cutting a small section (at least 12 in.) from the end of the board (Fig. 3).

#### Rating

- 4 - Oak and beech lumber are always checked for surface checks
- 3 - Oak and beech lumber are often checked for surface checks
- 1 - Oak and beech lumber are seldom checked for surface checks

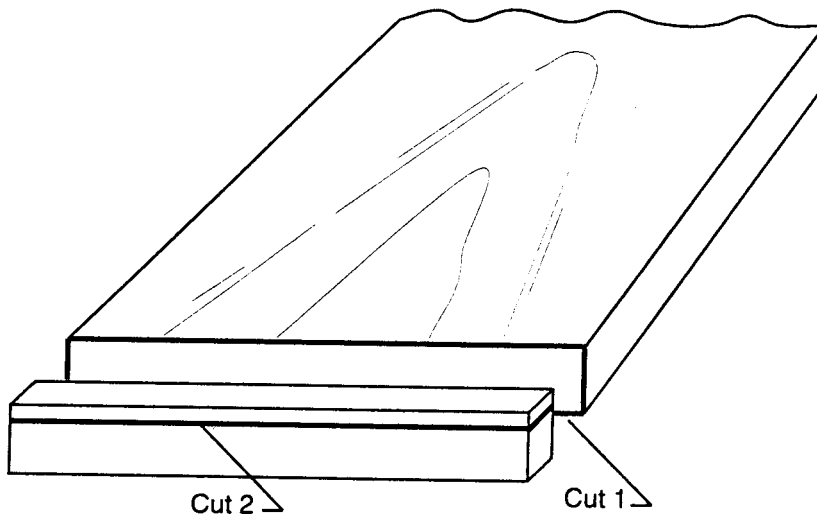

Figure 3. Inspect for surface checks by cutting a small section from end of board.

#### 10c. Recording of final moisture content

When target moisture content (MC) has been reached or when lumber is removed from the predryer to fill a dry kiln, the current or final moisture content should be measured and recorded. Any variation of moisture content with respect to location in the predryer should be noted.

##### Rating

- 4 - At least five MC readings are taken and recorded for each load
- 3 - MC readings are occasionally taken and recorded
- 1 - Final MC is not sampled

#### 10d. Initial set-point conditions of dry kiln for lumber from predryer

The initial conditions of the dry kiln where the lumber from the predryer will be dried to final target should generally be 1% EMC drier than the average moisture content value of the lumber coming from the predryer.

##### Rating

- 4 - Initial condition in the kiln is regularly 1% EMC below that in the predryer
- 3 - Initial condition in the kiln is usually 1% EMC below that in the predryer
- 1 - Initial condition in the kiln is not related to EMC in the predryer

# Checklist for Quality Drying in a Hardwood Lumber Predryer

## Standard Operating Practices

	<i>Low</i>	<i>High</i>
1a. Proper location of dry-bulb sensors .....	1	2 3 4
Rating		
4 - Dry-bulb sensors located in the entering air stream		
3 - Dry-bulb sensors located near the circulating fans		
2 - Dry-bulb sensors located more than 3 ft from the fans and not in the entering air stream		
1 - Dry-bulb sensors located close to the wall or roof		
1b. Influence of side vents on recorded dry-bulb temperatures .....	2	4
Rating		
4 - The dry-bulb sensor located on the west or north side of dryer is within 1°F of dry-bulb temperatures on the east or south side most of the time		
2 - The dry-bulb sensor located on the west or north side of dryer is more than 1°F lower than the dry-bulb temperatures on the east or south side most of the time		
1c. Proper location of the relative humidity (RH) sensor .....	1	2 3 4
Rating		
4 - RH sensors located in the entering air stream		
3 - RH sensors located near the circulating fans		
2 - RH sensors located more than 3 ft from the fans and not in the entering air stream		
1 - RH sensors located close to the wall or roof		
1d. Influence of side vents on recorded RH values .....	2	4
Rating		
4 - The RH on the west or north side should be within 2% RH of the RH on the east or south side most of the time		
2 - The RH on the west or north side is frequently more than 2% higher than on the east or south side		
1e. Use of wet-bulbs to determine RH values .....	1	2 3 4
Rating		
4 - Wick changed weekly, water is clean, about 80°F, and air velocity across wick is about 600 fpm		
3 - Wick changed weekly, water is clean, about 80°F, and air velocity across wick is about 400 fpm		
2 - Wick changed weekly, water is clean, about 80°F, and air velocity across wick is about 200 fpm		
1 - Wick is changed less than once per week		
1f. Use of EMC sensor to determine humidity in predryer .....	1	2 3 4
Rating		
4 - EMC wafer is changed weekly; calibration is confirmed monthly		
3 - EMC wafer is changed weekly; calibration is rarely checked		
2 - EMC wafer is changed less than once a week; calibration is confirmed monthly		
1 - EMC wafer is rarely checked		

	<b>Low</b>			<b>High</b>
1g. Air supply to control instruments and operating valves checked at regular intervals .....	1	2	3	4
Rating				
4 - Air compressor is checked and drained daily				
3 - Air compressor is inspected on some schedule, but at least monthly				
2 - Air compressor is inspected only when a problem is suspected				
1 - Air compressor is inspected only when the controller or air supply does not work				
1h. Drip pans positioned below roof vents .....		2		4
Rating				
4 - Drip pans are positioned below all roof vents, and are of sufficient capacity to retain all condensate or have drains provided				
2 - No drip pans present				
1i. Condensation of water on predryer floor .....	1	2	3	4
Rating				
4 - Condensation on the floor is rarely or never seen				
3 - On the coldest days, a little condensation may be seen				
2 - Occasionally a little condensation may be seen				
1 - Wet spots are frequently seen				
1j. Removal of dirt and debris from predryer floor .....	1	2	3	4
Rating				
4 - Floor cleaned weekly				
3 - Floor cleaned once a month				
2 - Floor cleaned two times a year				
1 - Floor never cleaned				
1k. Roof is free of leaks .....	1	2		4
Rating				
4 - No leaks seen				
2 - Roof leaks on days with heavy rains				
1 - Roof leaks frequently				
1l. Traps checked for proper operation and plumbed for ease of checking .....	1		3	4
Rating				
4 - Each bank of coils has its own trap and check valve				
3 - Each main heat coil is trapped, but side vent heaters are not individually trapped				
1 - Several banks of coils use one trap or check valves not installed				
1m. Circulating fans turning in proper direction and lubricated properly .....	1	2	3	4
Rating				
4 - All fan motors turn the same direction and are lubricated at manufacturers specified intervals				
3 - All fan motors turn the same direction and are NOT lubricated at manufacturers specified intervals				
2 - Fans seldom checked to see if all running and turning in same direction				
1 - Fans not checked and are lubricated only when problem occurs				
1n. Exhaust fans turning for proper airflow and lids closing properly .....		2		4
Rating				
4 - Exhaust fans and lids checked monthly; lubricated as needed				
2 - Exhaust fans and lids not checked monthly and/or not lubricated				

	<b>Low High</b>
1o. Proper functioning of side vents .....	1 2 3 4
Rating	
4 - Proper operation of side vents checked weekly	
3 - Proper operation of side vents checked monthly	
2 - Proper operation of side vents checked semi-annually	
1 - Proper operation of side vents checked only when problems occur	

1p. General building inspection .....	1 2 3 4
Rating	
4 - Thorough check and report provided to management every 6 weeks	
3 - Thorough check and report provided to management every 3 months	
2 - Inspection and report provided annually	
1 - Not inspected; no report prepared	

1q. Heating coils clean and free of debris .....	1 3 4
Rating	
4 - Coils clean and free of obstructions	
3 - Coils fairly clean (slight rust) and free of obstructions	
1 - Coils with heavy rust; coils blocked with debris	

**2. Moisture Content Monitoring and Recordkeeping**

2a. Knowledge of history of lumber before going into predryer .....	1 3 4
Rating	
4 - History of the lumber and the MC of the lumber going into the predryer are known	
3 - You can reconstruct the history and have taken a few moisture readings	
1 - No effort was made to learn the history or to determine the MC	

2b. Use of sample boards (kiln samples) to monitor moisture content .....	1 2 3 4
Rating	
4 - Sample boards are always selected, prepared, placed, and used as recommended in Chapter 6 of the DKOM	
3 - Sample boards are usually used, with minimal attention to selection and usually only 2 or 3 boards used per 100,000 board feet	
2 - Sample boards are rarely used	
1 - Sample boards are never used	

2c. Disposition of lumber after removal from predryer .....	1 2 3 4
Rating	
4 - Lumber always goes directly to the kiln	
3 - Lumber always goes to kiln or to unheated covered storage building	
2 - Lumber usually goes to kiln or to unheated storage building	
1 - Lumber usually goes to unprotected storage	

2d. Identification of packages of lumber in predryer .....	1 3 4
Rating	
4 - Individual packages are monitored	
3 - Entire or partial kiln loads are monitored as a group	
1 - No records are regularly maintained	

**3. Learning Opportunities**

	<b>Low</b>			<b>High</b>
	1	2	3	4
3a. Opportunities to visit other sites and meet other operators .....				
Rating				
4 - Visit other predryer sites three or more times per year				
3 - Visit other predryer sites twice a year				
2 - Visit other predryer sites once a year				
1 - Never visit other predryer sites				
3b. Attend dry kiln association meetings and drying workshops .....				
Rating				
4 - Attend dry kiln association meetings yearly and have attended at least one workshop				
3 - Regularly attend meetings but have never been to a workshop				
2 - Attend meetings every 2 or 3 years				
1 - Never attend meetings or workshops				

**Control Room**

**4. Environmental Conditions in Control Room Appropriate**

4a. Temperature and relative humidity controlled for good working conditions of personnel and control instrumentation .....				
Rating				
4 - Control room is always well heated and air conditioned				
3 - Control room is well heated and air conditioned most days				
1 - Temperature and RH in control room considered not important				

**5. Instrument Charts**

5a. Correct instrument charts are used .....				
Rating				
4 - Chart paper matches recording instrument				
1 - Wrong chart paper is used				
5b. Chart record is clear and legible .....				
Rating				
4 - Charts are changed weekly with clear legible tracings				
1 - Charts are changed infrequently, overwritten, provide no useful recording of conditions				

**Lumber Stacking and Loading of Predryer**

**6. Sticker and Bolster Thickness**

6a. Sticker thickness uniformity .....				
Rating				
4 - Range of sticker thickness is 1/32 in. (0.031 in.) or less				
3 - Range of sticker thickness is 1/16 in. (0.063 in.) or less				
2 - Range of sticker thickness is 1/8 in. (0.125 in.) or less				
1 - Range of sticker thickness is greater than 1/8 in. (0.125 in.)				



	<b>Low</b>			<b>High</b>
6b. Bolster thickness uniformity .....	1	2	3	4
Rating				
4 - Range of bolster thickness is 1/8 in. (0.125 in.) or less				
3 - Range of bolster thickness is 1/4 in. (0.250 in.) or less				
2 - Range of bolster thickness is 3/8 in. (0.375 in.) or less				
1 - Range of bolster thickness is greater than 3/8 in. (0.375 in.)				
6c. Uniformity of sticker straightness .....	1	2	3	4
Rating				
4 - All stickers have less than 2 in. of crook or kink				
3 - No more than 3 of the 20 stickers have 2 in. or more of crook or kink				
2 - No more than 5 of the 20 stickers have 2 in. or more of crook or kink				
1 - More than 5 of the 20 stickers have 2 in. or more of crook or kink				
6d. Lumber thickness variation .....	1	2	3	4
Rating				
4 - All boards are uniform and touching stickers; stickers are not bent				
3 - Fewer than 10 boards per package do not touch stickers or stickers bend slightly over thick or thin lumber				
2 - Thickness variation is sufficient to bend stickers or show gaps more than 1/8 in. wide above boards				
1 - Thickness variation is great enough to make stacking visibly irregular				
6e. Painted lines on floor help proper positioning of stacks .....	1	2		4
Rating				
4 - Lines easily seen and properly located				
2 - Lines obscure or worn away				
1 - No lines on floor				
6f. Plenum width adequate .....	1	2	3	4
Rating				
4 - Plenum width (in ft) is at least the total pile height (in ft) divided by 5 and fewer than 1 out of 25 top stacks is slightly in the plenum area				
3 - Plenum width (in ft) is at least the total pile height (in ft) divided by 5 and fewer than 1 out of 10 top stacks is slightly in the plenum area				
2 - Fewer than 1 out of 5 top stacks is slightly in the plenum area; plenum width is significantly less than suggested				
1 - Many stacks are encroaching on the plenum area				
6g. Spacing between lumber piles .....	1	2	3	4
Rating				
4 - Spacing between adjacent lumber piles is 4 to 5 in., consistently				
3 - Spacing between adjacent lumber piles is 3 to 8 in., consistently				
2 - More than 1 out of 4 adjacent piles is closer than 3 in.				
1 - Spacing is often under 3 in.				

## Operational Checks

### 7. Dry-Bulb Temperatures

7a. Typical range of operating temperatures .....	2			4
Rating				
4 - Dry-bulb temperature is between 80°F to 90°F (85°F to 95°F in summer)				
2 - Dry-bulb temperature is less than 80°F or more than 90°F				

	<b>Low</b>		<b>High</b>
7b. Accuracy of dry-bulb sensors .....	1	2	3 4
Rating			
4 - Dry-bulb temperature is checked every 3 months and is within 1°F of the temperature indicated on the recorder/readout/controller for all sensors			
3 - Dry-bulb temperature is checked every 3 months and is within 1°F of the temperature indicated on the recorder for 80% of the sensors (2°F on others)			
2 - Dry-bulb temperature is checked at least every 6 months and is within 2°F of the temperature indicated on the recorder for all sensors			
1 - Dry-bulb temperature is not checked regularly, or there is a difference of 2°F on one or more sensors			
7c. Daily variation of dry-bulb temperature .....	1	2	3 4
Rating			
4 - Variation within $\pm 1/2^\circ\text{F}$ throughout the day			
3 - Variation within $\pm 1^\circ\text{F}$ throughout the day			
2 - Variation within $\pm 2^\circ\text{F}$ throughout the day			
1 - Variation more than 2°F throughout the day			
7d. Dry-bulb temperature variation within control zone .....	1	2	4
Rating			
4 - Variation within $\pm 1^\circ\text{F}$			
2 - Variation within $\pm 2^\circ\text{F}$			
1 - Variation more than $\pm 2^\circ\text{F}$			
7e. Selecting “controlling zone” dry-bulb temperature .....	1		4
Rating			
4 - Controlling bulb/sensor is where the wettest lumber is located			
1 - Controlling bulb/sensor is NOT where the wettest lumber is located			
7f. Possible shut-down of predryer when main door is open .....	1	2	4
Rating			
4 - Fans are turned off when main door is open and dry-bulb temperature changes by 2°F			
2 - Fans are turned off when main door is open and dry-bulb temperature changes by 4°F			
1 - Fans always run when main door is open			

**8. Wet-Bulb Temperatures, RH, or EMC**

8a. Accuracy of wet-bulb sensor .....	1	2	3 4
Rating			
4 - Wet-bulb sensors are checked every 3 months and are within $\pm 2\%$ RH			
3 - Wet-bulb sensors are checked every 3 months and are within $\pm 4\%$ RH			
2 - Wet-bulb sensors are checked less frequently than every 3 months and are within $\pm 2\%$ RH			
1 - Wet-bulb sensors are rarely checked or are out of calibration			
8b. Accuracy of relative humidity sensor(s) .....	1	2	3 4
Rating			
4 - RH sensors are checked monthly and are within $\pm 2\%$ RH			
3 - RH sensors are checked monthly and are within $\pm 4\%$ RH			
2 - RH sensors are checked less frequently than once a month and are within $\pm 2\%$ RH			
1 - RH sensors are rarely checked or are out of calibration			

	<b>Low</b>	<b>High</b>	
8c. Daily variation of wet-bulb temperature .....	1	2	4
Rating			
4 - Daily variation is within the limits specified			
2 - Daily variation is within twice the limits specified			
1 - Daily variation is greater than twice the limits specified			
8d. Possible shut-down of fans when main door is open .....	1	2	4
Rating			
4 - Fans are turned off when main door is open and RH changes by 5% RH or 1-1/2% EMC			
2 - Fans are turned off when main door is open and RH changes by 10% RH or 3% EMC			
1 - Fans always run when main door is open			
8e. RH limits in predryer when loading wet lumber .....	1	2	4
Rating			
4 - Actual RH exceeds desired value by 3% or less			
2 - Actual RH exceeds desired value by 3% to 5%			
1 - Actual RH exceeds desired value by more than 5%			

**9. Fan Operation and Air Velocity**

9a. Fans turning for proper airflow .....	1	2	3	4
Rating				
4 - Fans are checked for proper operation (rotation, rpm, pitch) once a year, and all fans are observed each week to determine if all fans are operating				
3 - Fans are checked for proper operation (see above) once a year, and weekly check indicates all but one fan is operating				
2 - Fans are checked for proper operation (see above) once a year, and weekly check indicates all but two fans are operating				
1 - Fans are not checked frequently; only when problems arise				
9b. Average air velocity through the load .....	1	2	3	4
Rating				
4 - Air velocity is checked on each load and is 100 to 150 ft/min on the average				
3 - Air velocity is checked on each load and is 75 to 175 ft/min on the average				
2 - Air velocity is checked occasionally and is 75 to 175 ft/min on the average				
1 - Air velocity is rarely checked				
9c. Air velocity uniformity/variation through the stacks .....	1	2	3	4
Rating				
4 - Air velocity measurements do not vary by more than +25 ft/min				
3 - Air velocity measurements do not vary by more than +50 ft/min				
2 - Air velocity measurements do not vary by more than +75 ft/min				
1 - Air velocity measurements vary by more than +75 ft/min				
9d. Use of baffles in plenum space .....	1	3	4	
Rating				
4 - Plenum baffle always used				
3 - Plenum baffle usually used				
1 - Plenum baffle seldom or never used				
9e. Use of end baffles .....	1			4
Rating				
4 - End baffles always used				
1 - End baffles NOT used				

	<b>Low</b>	<b>High</b>
9f. Use of tapered bolsters .....	1	4
Rating		
4 - Tapered bolsters always used		
1 - Tapered bolsters NOT used		
9g. Burlap wrap for thick lumber .....	1	4
Rating		
4 - Burlap wrap used as appropriate		
1 - Burlap wrap rarely or never used		
9h. Fan control within a control zone .....	1	3 4
Rating		
4 - Fans in a zone can be turned on/off easily		
3 - Fans in a zone can be turned on/off with difficulty		
1 - Fans in a zone cannot be turned on/off independently		

### **Monitoring Drying Rate and Degrade Formation**

10a. Use of sample boards to monitor drying rate.....	1	2	3	4
Rating				
4 - Sample boards are used and are checked three times per week				
3 - Sample boards are used and are checked once a week				
2 - Sample boards are seldom used				
1 - Sample boards are never used				
10b. Monitoring presence of surface checking on incoming lumber.....	1	3	4	
Rating				
4 - Oak and beech lumber are always checked for surface checks				
3 - Oak and beech lumber are often checked for surface checks				
1 - Oak and beech lumber are seldom checked for surface checks				
10c. Recording of final moisture content .....	1	3	4	
Rating				
4 - At least five MC readings are taken and recorded for each load				
3 - MC readings are occasionally taken and recorded				
1 - Final MC is not sampled				
10d. Initial set-point conditions of dry kiln for lumber from predryer .....	1	3	4	
Rating				
4 - Initial condition in the kiln is regularly 1% EMC below that in the predryer				
3 - Initial condition in the kiln is usually 1% EMC below that in the predryer				
1 - Initial condition in the kiln is not related to EMC in the predryer				

## **Appendix 1 Summary Checklist for Quality Drying in a Hardwood Lumber Predryer**

Appendix 1 contains all the items from the checklist and in the same order; only the rating system has been omitted. This will shorten the number of checklist pages, and filing the checklist with the kiln records will require less space.

Predryer \_\_\_\_\_

Date \_\_\_\_\_

## Summary Checklist for Quality Drying in a Hardwood Lumber Predryer

### Standard Operating Practices

#### 1. Maintenance and Inspection

	<b>Low</b>	<b>High</b>
1a. Proper location of dry-bulb sensors .....	1	2 3 4
1b. Influence of side vents on recorded dry-bulb temperatures .....	2	4
1c. Proper location of the relative humidity (RH) sensor .....	1	2 3 4
1d. Influence of side vents on recorded RH values .....	2	4
1e. Use of wet-bulbs to determine RH values .....	1	2 3 4
1f. Use of EMC sensor to determine humidity in predryer .....	1	2 3 4
1g. Air supply to control instruments and operating valves checked at regular intervals .....	1	2 3 4
1h. Drip pans positioned below roof vents .....	2	4
1i. Condensation of water on predryer floor .....	1	2 3 4
1j. Removal of dirt and debris from predryer floor .....	1	2 3 4
1k. Roof is free of leaks .....	1	2 4
1l. Traps checked for proper operation and plumbed for ease of checking .....	1	3 4
1m. Circulating fans turning in proper direction and lubricated properly .....	1	2 3 4
1n. Exhaust fans turning for proper airflow and lids closing properly .....	2	4
1o. Proper functioning of side vents .....	1	2 3 4
1p. General building inspection .....	1	2 3 4
1q. Heating coils clean and free of debris .....	1	3 4

#### 2. Moisture Content Monitoring and Recordkeeping

2a. Knowledge of history of lumber before going into predryer .....	1	3 4
2b. Use of sample boards (kiln samples) to monitor moisture content .....	1	2 3 4
2c. Disposition of lumber after removal from predryer .....	1	2 3 4
2d. Identification of packages of lumber in predryer .....	1	3 4

#### 3. Learning Opportunities

3a. Opportunities to visit other sites and meet other operators .....	1	2 3 4
3b. Attend dry kiln association meetings and drying workshops .....	1	2 3 4

### Control Room

#### 4. Environmental Conditions in Control Room Appropriate

4a. Temperature and relative humidity controlled for good working conditions of personnel and control instrumentation .....	1	3 4
---	---	-----

#### 5. Instrument Charts

5a. Correct instrument charts are used .....	1	4
5b. Chart record is clear and legible .....	1	4

## Lumber Stacking and Loading of Predryer

### 6. Sticker and Bolster Thickness

	<b>Low</b>		<b>High</b>
6a. Sticker thickness uniformity .....	1	2 3 4	4
6b. Bolster thickness uniformity .....	1	2 3 4	4
6c. Uniformity of sticker straightness .....	1	2 3 4	4
6d. Lumber thickness variation .....	1	2 3 4	4
6e. Painted lines on floor help proper positioning of stacks .....	1	2	4
6f. Plenum width adequate .....	1	2 3 4	4
6g. Spacing between lumber piles .....	1	2 3 4	4

## Operational Checks

### 7. Dry-Bulb Temperatures

7a. Appropriate range of operating temperatures .....		2	4
7b. Accuracy of dry-bulb sensors .....	1	2 3 4	4
7c. Daily variation of dry-bulb temperature .....	1	2 3 4	4
7d. Dry-bulb temperature variation within control zone .....	1	2	4
7e. Selecting "controlling zone" dry-bulb temperature .....	1		4
7f. Possible shut-down of predryer when main door is open .....	1	2	4

### 8. Wet-Bulb Temperatures, RH, or EMC

8a. Accuracy of wet-bulb sensor .....	1	2 3 4	4
8b. Accuracy of relative humidity sensor(s) .....	1	2 3 4	4
8c. Daily variation of wet-bulb temperature .....	1	2	4
8d. Possible shut-down when main door is open .....	1	2	4
8e. RH limits in predryer when loading wet lumber .....	1	2	4

### 9. Fan Operation and Air Velocity

9a. Fans turning for proper airflow .....	1	2 3 4	4
9b. Average air velocity through the load .....	1	2 3 4	4
9c. Air velocity uniformity/variation .....	1	2 3 4	4
9d. Use of baffles in plenum space .....	1		3 4
9e. Use of end baffles .....	1		4
9f. Use of tapered floor bolsters .....	1		4
9g. Burlap wrap for thick lumber .....	1		4
9h. Fan control within a control zone .....	1		3 4

### 10. Monitoring Drying Rate and Degrade Formation

10a. Use of sample boards to monitor drying rate .....	1	2 3 4	4
10b. Monitoring for presence of surface checking on incoming lumber .....	1		3 4
10c. Recording of final moisture content .....	1		3 4
10d. Initial set point conditions of dry kiln for lumber from predryer.....	1		3 4

## **Appendix 2**

### **Checklist Arranged by Drying System Components**

Appendix 2 contains the same items as the checklist, but it is arranged so that all the components related to one system are together. For example, all items related to fans are grouped together. The item number is the same as in the guidebook section. If you have a question about a particular item, refer to the guidebook by its item number (for example, 7b.).



Predryer\_\_\_\_\_

Date\_\_\_\_\_

## Checklist Arranged by Drying System Components

### Predryer Structure

	<i>Low</i>			<i>High</i>
1h. Drip pans positioned below roof vents .....	2			4
1i. Condensation of water on predryer floor .....	1	2	3	4
1j. Removal of dirt and debris from predryer floor .....	1	2	3	4
1k. Roof is free of leaks .....	1	2	3	4
1p. General building inspection .....	1	2	3	4

### Fans and Motors

1m. Circulating fans turning in proper direction and lubricated properly .....	1	2	3	4
1n. Exhaust fans turning for proper airflow and lids closing properly .....		2		4
9a. Fans turning for proper airflow .....	1	2	3	4

### Baffles and Plenum

6f. Plenum width adequate .....	1	2	3	4
9d. Use of baffles in plenum space .....	1		3	4
9e. Use of end baffles .....	1			4

### Air Velocity and Variation

9b. Average air velocity through the load .....	1	2	3	4
9c. Air velocity uniformity/variation .....	1	2	3	4
9g. Burlap wrap for thick lumber .....	1			4

### Heating System

1b. Influence of side vents on recorded dry-bulb temperature .....		2		4
1l. Traps checked for proper operation and plumbed for ease of checking .....	1		3	4
1q. Heating coils clean and free of debris .....	1		3	4
7a. Appropriate range of operating temperatures .....	1	2	3	4
7b. Accuracy of dry-bulb sensors .....	1	2	3	4
7c. Daily variation of dry-bulb temperature .....	1	2	3	4
7d. Dry-bulb temperature variation within control zone .....	1	2		4
7e. Selecting "controlling zone" dry-bulb temperature .....	1			4
7f. Possible shut-down of predryer when main door is open .....	1	2		4

### Venting-Humidification System

1d. Influence of side vents on recorded RH values .....		2		4
1e. Use of wet-bulbs to determine RH values .....	1	2	3	4
1f. Use of EMC sensor to determine humidity in predryer .....	1	2	3	4
1o. Proper functioning of side vents .....	1	2	3	4
8a. Accuracy of wet-bulb sensor .....	1	2	3	4
8b. Accuracy of relative humidity sensor(s) .....	1	2	3	4
8c. Daily variation of wet-bulb temperature .....	1	2		4
8d. Possible shut-down of predryer when main door is open .....	1	2		4
8e. Relative humidity limits in predryer when loading wet lumber .....	1	2		4

## Control System

	<b>Low</b>			<b>High</b>
1a. Proper location of dry-bulb sensors .....	1	2	3	4
1c. Proper location of relative humidity sensors .....	1	2	3	4
1g. Air supply to control instruments and operating valves checked at regular intervals .....	1	2	3	4
4a. Temperature and relative humidity is controlled for good working conditions of personnel and control instrumentation .....	1		3	4
5a. Correct instrument charts are used .....	1			4
5b. Chart record is clear and legible .....	1			4
9h. Fan control within a control zone .....	1		3	4

## Stacking Practices

6a. Sticker thickness uniformity .....	1	2	3	4
6b. Bolster thickness uniformity .....	1	2	3	4
6c. Uniformity of sticker straightness .....	1	2	3	4
6d. Lumber thickness variation .....	1	2	3	4

## Package Placement

6e. Painted lines on floor help proper positioning of stacks.....	1	2	3	4
6g. Spacing between lumber piles.....	1	2	3	4
9f. Use of tapered floor bolsters.....	1			4

## Moisture Content Checks, Drying Rate, and Degrade

2a. Knowledge of history of lumber before going into predryer .....	1		3	4
2b. Use of sample boards (kiln samples) to monitor moisture content .....	1	2	3	4
2c. Disposition of lumber after removal from predryer .....	1	2	3	4
2d. Identification of packages of lumber in predryer .....	1		3	4
10a. Use of sample boards to monitor drying rate .....	1	2	3	4
10b. Monitoring for presence of surface checking on incoming lumber .....	1		3	4
10c. Recording of final moisture content .....	1		3	4
10d. Initial set-point conditions of dry kiln for lumber from predryer .....	1		3	4

## Communication and Learning Opportunities

3a. Opportunities to visit other sites and meet other operators .....	1	2	3	4
3b. Attend dry kiln association meetings and drying workshops .....	1		3	4