



## Measurement of Earlywood and Latewood Properties in Loblolly Pine

thicker walled with much smaller radial lumen diameters (Fig. 1). But there currently are no means to translate these observations to wood product performance.

The ratio of specific gravity of latewood to earlywood in loblolly pine is typically 2 to 1 or greater. Although the differences in earlywood and latewood specific gravities have been investigated, actual values of the mechanical properties of earlywood versus latewood are rare, and at present, we can only infer the consequences of these differences. We believe that in extreme cases, the latewood may be resisting most of the load, with the earlywood acting primarily as spacing material.

*Figure 1—Micrograph of latewood-earlywood transition in a piece of softwood.*

A large portion of the nation's future dimension lumber resource will come from genetically improved trees grown on intensively managed plantations. The focus of most tree breeders and forest managers is on increasing volume of wood fiber produced (i.e., fast growth). Fast growth can have negative impacts on the structural qualities of the wood products produced.

### Background

Traditional databases do not always characterize this new wood resource. An unacceptably high variability in stiffness and dimensional stability limits the use of the fast growth plantation wood. Earlywood and latewood property differences are believed to be a key contributor to this variability.

Current structural wood product design properties are developed from macroscale tests and visual inspection of products. Latewood percentage is one of the most widely used wood quality characteristics: it provides a visual index of strength and structural properties, is highly correlated with wood specific gravity, and is an important component in lumber and timber grading rules. Clearly defined relationships between latewood structure and solid wood properties do not exist.

We know latewood tracheids can be over twice as strong as earlywood tracheids. Latewood tracheids are also

### Approach

Loblolly trees in a southern pine plantations in Arkansas were hand selected. The fertilization and pruning history of the plantation were recorded as well as the location and directional orientation of each stem. Bolts of 1.5 m (5 ft) were collected from each stem—one at breast height, one approximately 5 m (20 ft), and a third from 8 m (30 ft). The bolts were shipped to the Forest Products Laboratory (FPL) in Madison, Wisconsin.

At FPL, the bolts were cut into toothpick-size specimens, curved arcs, and full-size boards (Fig. 2) and stored under controlled environmental conditions.

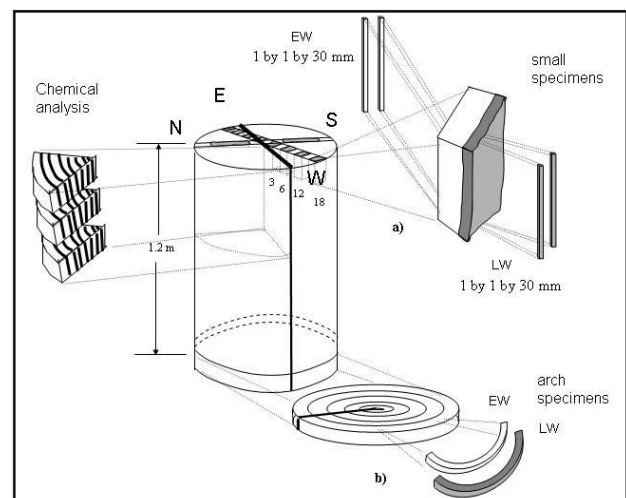

*Figure 2—Cut out pattern from the 5-ft bolt for loblolly pine specimens.*

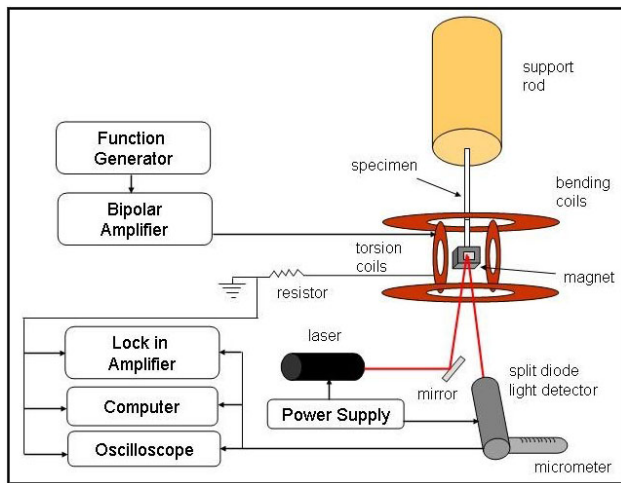

Figure 3—Schematic showing the inner components of the BVS micro tester elastic property measuring device.

### Test Methods

The E and G values were determined from bending and torsion tests, respectively, using a novel micromechanical testing device. This broadband viscoelastic spectroscopy (BVS) micro-testing device has been used extensively to study different viscoelastic materials. A simplified schematic showing the inner workings of the BVS is shown in Figure 3.

The small specimen is deflected by an electromagnetic torque produced by the action of an electric current in the Helmholtz coil upon a permanent magnet at one end. The resulting angular displacement is then measured optically by the split diode light detector. The specimen can be loaded in bending or torsion depending on which pair of coils is connected. Determining E in bending requires the addition of a dove or right angle prism to the micro-mechanics testing instrument. A dove prism must be placed in the beam path to change the direction of the beam motion from vertical to horizontal.

The small specimens are also being measured for longitudinal shrinkage, specific gravity, and microfibril angle using X-ray diffraction.

### What We Have Learned

The average earlywood E was  $630 \times 10^3 \text{ lb/in}^2$  and G was  $112 \times 10^3 \text{ lb/in}^2$ , and the average latewood E was  $1433 \times 10^3 \text{ lb/in}^2$  and G was  $230 \times 10^3 \text{ lb/in}^2$ . Although specific gravity was not a very reliable predictor of expected MOE or G for earlywood, it was slightly better for latewood. The modulus of elasticity of latewood compared to that of earlywood and the corresponding ratio in shear moduli are on average from 2.0 to 2.5 but can have high variability depending on the pith to bark location of sample. The ratios range from 0.6 to 7.0. For MOE, latewood has a more linear relationship with microfibril angle than does earlywood (Figures 4 and 5).

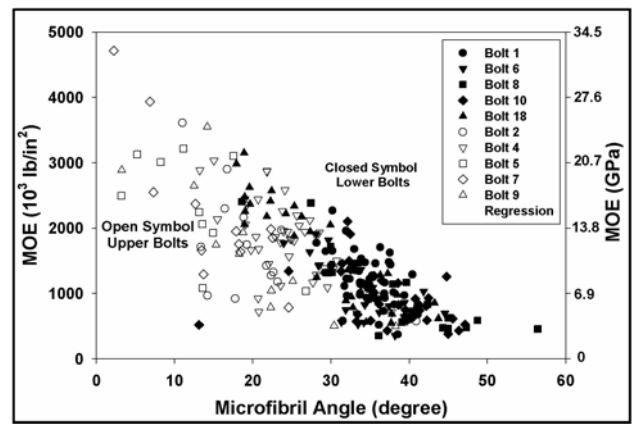

Figure 4—Earlywood MOE compared to Microfibril angle.

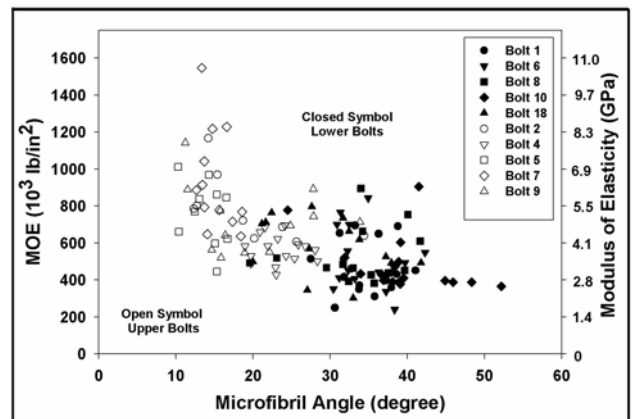

Figure 5—Latewood MOE compared to Microfibril angle.

Little correlation between microfibril angle and G appears to exist. The amount of shrinkage observed in earlywood and latewood is strongly influenced by the fibril angle.

### Learn More About It

Larson, P. R., Kretschmann, D. E., Clark III, A., Isenbrands J. G. 2001. Juvenile wood formation and properties in southern pine. Gen. Tech. Rep. FPL-GTR-129, Madison, WI, U.S. Department of Agriculture, Forest Service, Forest Products Laboratory. 42 p.

Kretschmann, D.E., Cramer, S.M., Lakes, R. Schmidt, T. 2005. Selected Mesostructure Properties in Loblolly Pine from Arkansas Plantations. In: Douglas D. Stokke and Leslie H. Groom, eds. Chapter 12, Characterization of the Cellulosic Cell Wall. Blackwell Publishing, Ames, Iowa.

Verrill, S. P.; Kretschmann, D. E.; Herian, V. L. 2001. JMFA—A graphically interactive Java program that fits microfibril angle X-ray diffraction data. Res. Note FPL-RN-0283. Madison, WI: U. S. Department of Agriculture, Forest Service, Forest products Laboratory. 44p.