

Strength of small-diameter round and tapered bending members

Ron Wolfe
Joe Murphy

Abstract

An early focus on structural use of processed rather than round timber resulted in an underestimation of the structural advantages of retaining the natural form of small-diameter round timber. In the round and tapered form, timbers are not susceptible to the strength-reducing effects of diving grain and exposed juvenile wood. Fiber continuity around knots on the surface of a debarked log rarely exhibits the stress concentration and fracture propagation commonly seen in disrupted grain around knots in lumber. Symmetry of material properties about the centroidal axis in a round timber improves the efficacy of standard section property equations derived for uniform isotropic materials. Ignoring these benefits and comparing the strength of round and processed timbers solely on the basis of section property, the round section has from two to four times the bending load design capacity of any standard-sized processed timber that could be sawn from it.

Dense stands of small-diameter trees (<9 in., 5 ft. [<228 mm, 1.5 m] off the ground) present a threat to our National Forests. Low demand for these trees makes it difficult to encourage thinning by private companies and thinning is prohibitively expensive for the government. One solution appears to be to develop value-added markets for this material, and one potential market is timber frame structures.

Structural use of small-diameter trees represents a major shift from tradition. This is especially true in the western United States, where the abundance of large trees encouraged rapid growth and evolution of the lumber industry. Larger trees yield structural lumber over a variety of standard widths. The mix of sizes results in a 90 percent yield of usable material from these trees. Small trees can be processed into lumber, but the conversion efficiency is reduced with log size.

In addition to the obvious size limitations on yield small trees containing a large proportion of juvenile wood often yield poor lumber quality. Juvenile wood is laid down within the active crown of the tree. It has characteristically lower strength and stiffness, greater longitudinal shrinkage with drying, and a larger proportion of knots than does mature wood that is produced below the active crown. Once the active crown moves higher in the tree to compete in the forest canopy, branches become less active and eventually die. In some cases, branches fall off, leaving a knot to be grown over by mature wood. In any case, knots rarely continue to grow in diameter in the mature wood of trees harvested

for lumber production. Knots therefore take up a smaller portion of the circumference and cross section in mature wood than in juvenile wood.

Reduced efficiency and quality associated with milling structural timbers from small-diameter trees that contain a large proportion of juvenile wood reduces the incentive to harvest these trees. There are, however, some advantages to using the stems from these trees in their natural form. Trees have evolved as structural elements efficiently designed to resist bending stresses. As the tree grows in height to compete for sunlight, it must either lay down stronger (mature wood) fiber or more fiber in the outer layers of the trunk to resist the higher bending moments caused by wind. Retaining this sheath of mature wood around the juvenile-wood core provides a bending element with strength and stiffness that has a higher mean value and lower variability than does lumber that is produced by sawing. Moreover, exposing juvenile wood by sawing can increase the tendency for warp.

Because small-diameter trees are naturally suited to use as bending elements, it seems logical that greater effort be expended to develop opportunities for their structural application in a round form. The only processing required for the debarked log is drying (air or kiln). Production of lumber from small-diam-

The authors are Research General Engineers, USDA Forest Serv., Forest Products Lab., One Gifford Pinchot Dr., Madison, WI 53726-2398. This paper was received for publication in November 2003. Article No. 9801.
©Forest Products Society 2005.
Forest Prod. J. 55(3):50-55.

eter trees requires sawing, grading, removal/recycling of residual sawdust and slabs, and careful stacking and weighting of the lumber for kiln-drying to minimize warp. In addition to lower processing costs, tapered round timber has higher average strength and lower variability than does lumber that is produced from it. These facts support the premise that structural applications of tapered round timbers have great potential for adding the value needed to encourage increased harvest.

The load capacity of any structural element is dependent on its physical dimensions as well as its material strength. Empirical data support the premise that the bending strength of round wood is greater and less variable than that of the lumber it would yield, besides the fact that the effective section properties of round wood are larger than those of lumber produced from it. This premise, however, is based primarily on tests of large poles and of commodity market lumber that had not been sawn from small-diameter trees. Research is being done to obtain a more accurate assessment as applicable to small-diameter trees.

Objective

This paper evaluates the structural advantage of using small-diameter round timber in its natural form compared with sawing this wood to produce structural lumber. The purpose of this exercise is to quantify the potential advantage of promoting the structural use of tapered round timbers on the basis of geometrical considerations.

Literature

There are currently few structural applications for round timbers; they have, however, been used in utility structures for more than 100 years in the United States. Standards are available for the specification and design of round timbers for use in utility structures (ASC 2002), pile foundations (ASTM 1999, 2001), pole frame storage buildings (ASAE 1978, ASTM 2000), and log buildings (ASTM 1996). The Accredited Standards Committee (ASC), which oversees the maintenance of standards for utility poles, has compiled a database comprised of more than 4,000 pole tests for U.S. domestic species that is used to support the derivation of design strength for utility structures. However, timber pile and pole building design values are still based on strength

tests of small, clear wood. Existing design procedures recognize lower variability and lower sensitivity to grade effects for round timbers (AF&PA 1997; ASTM 2000,2001; ASC 2002) as opposed to lumber, but as a result of limited markets, these values are not widely recognized in building codes for applications in more highly engineered applications.

Engineered use of round timber has been demonstrated in a wide variety of structural applications (VTT 1999, Wolfe et al. 2000). Incompatibility with conventional construction and limited understanding of juvenile wood effects on connection capacity appear to be the primary factors that inhibit the development of widely recognized design standards.

Load capacity

The load capacity of any structural member is a function of its material strength and section properties. Naturally, reducing section property reduces load capacity, making any sawn timber weaker than the round timber it was sawn from. Machining the surface of the raw log also creates a perceived material strength loss in that stress concentration points initiate fractures and effectively reduce the calculated extreme fiber stress at failure. These stress concentration points also influence an increased strength variability. The result of reduced section property, lower mean strength, and higher variability for machined sections is a lower design load capacity. This is especially true for timbers loaded in bending. The round tapered section of the natural small-diameter tree stem potentially has two to four times the bending load design capacity of any standard-sized timber that can be sawn from it. A brief review of the section and material properties of round timber provides some support for efforts to promote structural use of small diameter timber in its natural tapered form.

Section properties of round and rectangular beams

In comparing round and rectangular beams, two section properties must be considered. Beam design may be controlled by the moment of inertia (I) or by section modulus (S). Moment of inertia (I), the second moment of the area about the neutral axis of the cross section, multiplied by the bending modulus of elasticity, gives a measure of stiffness or resistance to deflection. Section modulus

($S = I$, divided by distance from extreme fiber to neutral axis), when multiplied by the allowable extreme fiber stress, gives an estimate of the moment or bending-load capacity of the beam.

These two section properties (I and S) are basically composite estimates of the amount of material weighted by its distance from the neutral axis. They are derived assuming that the material properties are uniform throughout the section and are generally applied assuming that the "neutral" axis, referring to an axis of zero stress (where compressive stress on one side is balanced by tensile stress on the other side) coincides with the geometric center or centroidal axis independent of the stress level. This assumption is generally accepted in design and is therefore appropriate for the comparison of round and rectangular timber section properties.

Stress control. — The bending moment capacity of a beam is a product of the bending stress at failure or modulus of rupture (MOR) and the section modulus. As wood is not a uniform isotropic material, sawing can have a significant impact on MOR by exposing juvenile wood or grain deviations (at knots or resulting from natural taper) to regions of high stress. In this paper, we only deal with geometry and assume that MOR is not affected by processing. In this case, the ratio of moment capacities for rectangular as opposed to round sections is simply the ratio of their section moduli. A rectangular section loaded perpendicular to its narrow face (b) would have a section modulus given by Equation [1]:

$$S_{rect} = \frac{bh^2}{6} \quad [1]$$

The round section has a section modulus given by Equation [2]:

$$S_{round} = \frac{\pi d^3}{32} \quad [2]$$

As shown in **Figure 1**, the maximum dimensions of a rectangle of any given aspect ratio ($h:b$) sawn from a circular section can be determined by setting the diameter (d) of the circle to the diagonal of the inscribed rectangle:

$$[3]$$

Given that the diagonal of the rectangular section is always equal to the diameter of the circle, the maximum section modulus ratio ($SR = \text{round:rectangular}$) would fall in the range of 1.5 to 3

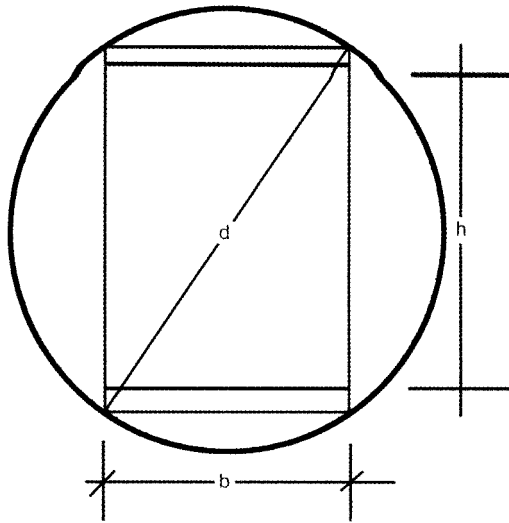

Figure 1. — Rectangular section limited by small-end diameter (d) and standard dimensions ($b \times h$).

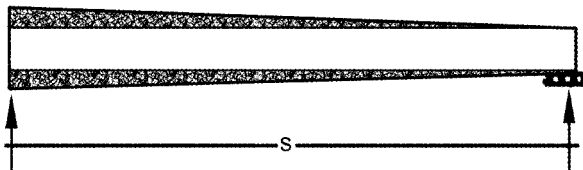

Figure 2. — Tapered beam contains added material (shaded) where moments are largest.

Table 1. — Taper effect on ratio of tapered vs. uniform section beam load capacity.

a (Lt / C_t)	Location of maximum stress in tapered beam ^a		Moment capacity ratio (tapered to uniform)		Effective stiffness ratio (tapered to uniform)	
	Max stress	Max deflection	Uniform load	Center-point load	Uniform load	Center-point load
0.000	0.50	0.50	1.00	1.00	1.00	1.00
0.150	0.45	0.48	1.22	1.24	1.32	1.34
0.200	0.43	0.48	1.28	1.33	1.44	1.46
0.300	0.40	0.47	1.41	1.52	1.70	1.75

^aDistance expressed as fraction of beam length from tip.

(see SR in Appendix) for American Lumber Standard (ALS) sizes taken from round sections ranging from 4 to 9 inches (100 to 230 mm) in diameter. Of course, logs do not grow in standard increments equal to the diagonal dimension of ALS sizes, so the diagonal of standard sawn timber will generally be less than that of the log diameter, resulting in higher SR values. For example, a nominal 3- by 4-inch (standard 64- by 89-mm) timber cut from a 7-inch-(178-mm-) diameter log would yield $SR > 6$.

Some people argue that the ratio is not that great because the rectangular section loaded on its diagonal has a greater section modulus. While valid from a the-

oretical perspective, this argument is impractical from a structural perspective and is not considered here.

Deflection control. — In the majority of cases, timber beam structural applications are controlled by a deflection limit, rather than a stress limit. In these cases, the load capacity ratio (round:rectangular) is a function of the section I . If we assume modulus of elasticity does not change with machining, and again assume uniform sections along the length, the load capacity ratio is simply the ratio of I values for rectangular to round sections.

Following the same logic as that used for deriving the section modulus ratio,

the maximum round-to-rectangular ratio (IR) for sections having the same diagonal/diameter and standard thickness dimensions will range from 1.8 to 3.1. If restricted to ALS standard depth dimensions, this ratio increases to the range of 2.3 to 4.2, giving the round section a load capacity that could potentially range from 1.8 to 4.2 times that of the rectangular section.

Tapered vs. uniform timber

Taper adds to the capacity of a round timber by providing added section where moments are largest. In the case of a simply supported beam (Fig. 2), the maximum stress location varies with load and taper. Under a center-point load, the maximum stress for a tapered log with taper less than the small-end diameter divided by the length (majority of small-diameter logs) will occur at mid-span. For a uniformly loaded beam, the location of maximum stress (M/S) will vary with the taper. The location can be calculated by setting the first derivative of the M/S equation to zero and solving for distance from the tip. This value is given in Table 1 as the fraction of the span from the tip end. The ratio of section modulus at any point over the span of a tapered round beam to that at its tip will be:

$$SR_x = (C_t + kL\tau)^3 / C_t^3 = (l + kL\tau / C_t)^3 \quad [4]$$

where:

C_t = tip circumference (in.)

k = fraction of length from tip end

t = circumference taper expressed as proportion of change in length

L = span length (in.)

To remove the effect of units from this expression, substitute a for Lt/C_t :

$$SR_x = (l + ka)^3 \quad [5]$$

The effective stiffness ratio (Table 1) was calculated as the ratio of the maximum deflection of a uniform vs. a tapered round timber. The maximum deflections for the tapered section under uniform load occurred at 47 to 50 percent of the beam length from the tip. In the case of the center-point loads, maximum stress as well as maximum deflection was assumed to occur at mid-span.

Because the small-diameter logs considered for beams will rarely exceed 20 feet (6 m) with a 2 percent ($t = 0.02$) circumference taper and a 5-inch (127-mm)

Table 2 — Comparison of bending capacity on basis of geometry alone^a

Tip diameter		Sawn timber dimension				Capacity ratio	
		<i>b</i>		<i>h</i>		round	rectangular
(in.)	(mm)	(in.)	(mm)	(in.)	(mm)	Stress	Stiffness
4	100	1.5	38	3.5	89	21	3.5
5	130	3.5	89	3.5	89	22	3.4
6	150	3.5	89	4.5	114	2.2	3.2
7	180	3.5	89	5.5	140	2.3	3.1
8	200	5.5	140	5.5	140	2.2	3.3

^aValues based on a 12-foot (3.6-m) span round beam with 2 percent circumference taper

small-end diameter ($C_1 = 15.7$ in.), the maximum expected value of a would be 0.30. For larger small-end diameters and shorter lengths, the unit-less value of a is reduced, reaching zero at the point the end circumferences are equal or taper is zero.

This analysis shows that taper alone provides a significant increase in the load-carrying capacity of a beam, whether controlled by fiber stress or deflection. Within the range of realistic round timber lengths and taper, beams of tapered section whose design is controlled by fiber stress could have a moment capacity as much as 52 percent higher than that of a beam of uniform diameter. If the design is controlled by deflection, the more likely case, this ratio can exceed 1.7.

Tapered round vs. standard dimension

Adjustments for round vs. rectangular and for tapered vs. uniform section are multiplicative. If we have an option of cutting a standard dimension rectangular timber from a uniform round log having a diameter equal to the diagonal of the rectangular section, the load capacity of the round section will range from 1.5 to 3.0 times that of the rectangular sawn timber (see Appendix), depending on stiffness or deflection control. As shown in Table 1, a tapered round log with $a = 0.15$ could reasonably have 30 percent higher load capacity than that of a uniform round log. Multiplying these factors together suggests that a tapered round log could have a bending load capacity that is 2 to 4 times the capacity of the rectangular section.

Table 2 provides an analysis of a specific set of tapered logs, 12-foot- (3.6-m-) long logs with 2 percent taper. Standard dimension timbers were selected on the basis of log tip dimensions. Load capacities were then evaluated on the basis of section modulus at the maxi-

mum stress location and on the basis of beam deflection ratios.

This analysis suggests that on the basis of geometry alone, the bending load capacity of the tapered round beam is significantly greater than that of the largest sawn timber. This advantage is related to the small-end diameter, which is generally greater for smaller logs. However, the relationship is clouded by the limitations imposed by standard sawn timber sizes.

Other considerations

Other factors to consider when evaluating the effective load capacity of a small-diameter round timber include the effects of grade and variability on beam design, the advantages of round over square shape, and the waste generated by sawing. These factors are associated with reliability and fiber use efficiency and therefore, with cost competitiveness of the end product.

Grade and variability effects

Because round timber has not been widely used for structural applications, it has not received the attention given to sawn timber in terms of the derivation of design values. Experience in the areas of log stringer bridges (Tuomi et al. 1979), utility structures (Wood et al. 1960), and pile foundations (Bodig and Arnette 2000), however, has shown round timber strength to be relatively insensitive to knots and grain deviations. These studies show MOR coefficients of variation (COVs) ranging from 12 to 20 percent for poles of a variety of species and sizes, with lengths from 25 to 80 feet (7 to 24 m) and small-end diameters from < 6 to > 15 inches (< 152 to > 381 mm). Lumber, on the other hand, is sensitive to natural defects and must therefore be sorted to limit the effects of these grade-reducing characteristics on strength variability. Even with visual grading, Doyle and Markwardt (1966) showed graded

lumber to have MOR COV values in the range of 24 percent for No. 1 dense southern pine to 34 percent for No. 2 dense southern pine.

Differences between the strength properties of round and sawn timber are primarily associated with surface continuity. Grain on the surface of a tapered log runs parallel to the surface and flows around knots. In some cases, dead branches fall and mature wood subsequently grows over the knots, preventing the knots from disrupting the flow of stresses on the surface of the timber. When lumber is sawn, hidden knots are once again exposed and the grain deviation around the knot often ends at a rather steep angle to the sawn surface. This “diving” grain can have a major impact on strength at the location of the knot (Gerhards 1972). This effect is exhibited primarily as an increase in strength variability brought on by early failure at stress concentration points where grain comes to the surface. Data are limited on these effects as applied to peeled logs, as opposed to debarked logs. Peeling is generally not as critical in terms of the angle of the fiber to the surface, but it does expose juvenile wood, knots, and reaction wood which act as local areas of weakness.

If there is no significant difference in the average extreme fiber strength for round and sawn timber, the lower variability could result in a design value that is 30 percent greater for a round section. The standard approach to deriving timber design stress is based on strength at the lower 5 percent exclusion of a normal distribution. Assuming the MOR COV is 30 percent for graded lumber and 20 percent for tapered round timber, the ratio (R_d) of lower 5 percent exclusion values for tapered logs vs. lumber would be:

$$R_d = (1 - 1.645[.2]) / (1 - 1.645[.3]) = 1.32 \quad [6]$$

Multiplying this by the section factors of 1.5 to 3 discussed earlier results in a design capacity for the round tapered section that is 2.5 to 5.3 times that of a section sawn from it. A factor of 3 for load capacity of a round tapered section should provide sufficient incentive to develop efficient methods to take advantage of the structural capabilities of this material in its natural form.

Juvenile wood is another physiological property that can reduce mean stre-

Table 3. — Volume conversion, round to sawn timber.^a

Tip diameter		Sawn timber dimensions ^b		Sawn timber/log volume	
		Largest A	Largest S/I	A-match	S/I-match
(in.)	(mm)				
4	100	2 by 4	2 by 4	0.34	0.34
5	130	4 by 4	4 by 4	0.52	0.52
6	150	4 by 5	4 by 5	0.48	0.48
7	180	5 by 5	4 by 6	0.46	0.44
8	200	6 by 6	6 by 6	0.36	0.54
9	225	6 by 6	4 by 8	0.43	0.36

^aAssumes all logs are straight, 12 feet (3.6 m) long, with 2 percent linear circumference taper, no downfall due to degrade, one sawn timber per small-diameter round timber

^bAmerican Lumber Standard Committee, Inc. (1999)

ngth and increase variability for dimension lumber from small-diameter trees. Small-diameter logs maintained in the round form will often encase juvenile wood in a sheath of mature wood. A number of studies (Bendtsen and Senft 1986; Pearson and Gilmore 1971; A. Clark, III, personal communication) have shown that juvenile wood strength may vary from as low as 10 percent of the strength of mature wood at the pith to 90 percent of mature wood strength by 15 years. These values are species specific as well as site specific.

Form effect

Newlin and Trayer (1924) discovered a “form” effect that predicts an 18 percent greater bending moment capacity for a round section than for a square section. Newlin observed that the bending strength of clear wood cut to a uniform round section having a **4-in.**² (25.8-cm²) cross-sectional area had the same bending moment capacity as standard **2-inch** (51-mm) **square** clearwood test specimens. The square specimen, however, has an 18 percent greater section modulus, which means that it should have 18 percent higher bending load capacity. Newlin and Trayer proposed, therefore, that bending stress derived from standard small, clear tests should be increased to account for this form effect when applied to round timbers. Although this phenomenon has never been shown to be applicable to timbers in structural sizes, Newlin’s form factor has been referenced in the derivation of allowable stress for poles (Wood and Markwardt 1965) and piles (ASTM 2001).

Newlin and Trayer’s factor is not a ratio of effective section modulus, as discussed earlier. The effect they observed is most likely due to some inaccuracy in the material assumptions that form the

basis for the stress prediction. They did not note a stiffness advantage, so it is possible that the effect is in some way related to stress redistribution in the cross section beyond the proportional limit. In any case, if this represents a characteristic difference between the behavior of square and round sections, then it implies some inherent advantage for round beams when extreme fiber stress controls and a conventional design procedure is used.

Low-value residuals

Using round timber to produce structural lumber is risky and inefficient from the perspective of quality and use of wood fiber. **Table 3** provides an evaluation of the portion of fiber recovered in the form of sawn timber from round members with small-end diameter **£ 9 inches** (**£ 228 mm**). The fact that sawing primarily removes mature wood and leaves juvenile wood generally means a decrease in overall quality and allowable stress. If we assume that to minimize cost, the mill elects to take only one piece of sawn timber of a structural size from each small-diameter round timber, this also means that < 60 percent of the round timber volume will be recovered in the form of a structural timber product.

Table 3 shows the volume of fiber recovered in the form of sawn timber from 12-foot- (3.6-m-) long logs with a circumference taper of 2 percent. The recovery values range from 34 to 52 percent when sawing for either the maximum possible volume (largest A) or bending strength or stiffness (maximum S or I). These values are also influenced by the fact that the sizes being produced are standard timber sizes. If calculated strictly on the basis of the largest square section that can be obtained the ratios

would range from 0.51 to 0.57, increasing in proportion to the log diameter.

Conclusions

Small-diameter round timber beam elements used in their natural round and tapered form present a more efficient use of small-diameter material than does commodity market sawn lumber or timbers. On the basis of geometric considerations alone, round timber will have between two and four times the load capacity of any solid-sawn structural timber produced from it. Limited data compiled from tests of utility poles, piling, and logs for timber bridges suggest that visual grading has less effect on round timber strength than on lumber strength in part as a result of lower strength variability. The bending strength of round timber has a COV in the neighborhood of 20 percent as opposed to 30 percent for visually graded lumber. Taking this lower variability into account only serves to increase the design advantage of round timbers vs. processed small-diameter timbers. This conclusion needs further confirmation through tests of small-diameter round sections.

The “form” effect has never been confirmed for structural sizes. In a round timber where material properties are symmetric with respect to the centroidal axis, bending stress distribution is more likely to fit standard section property assumptions employed by conventional design equations for bending strength. It therefore seems likely that failure stress is more accurately estimated for round timbers than for sawn timbers. While the form factor is recognized, it is generally not used to the extent suggested by Newlin and Trayer (1924). The appropriateness of this adjustment for structural sizes should be verified.

Tapered beams of approximately round cross section offer many challenges for use in construction. Their tapered section and non-uniform outside dimensions present challenges in the areas of construction details and connections. However, their load capacity, when compared to that of any member that can be sawn from them, strongly supports efforts to promote value-added structural uses as a means of encouraging private industry to harvest and use this resource.

Literature cited

- Accredited Standards Committee (ASC). 2002. American National Standard for wood poles. ANS Institute Standard O5.1. ASC, Alliance

for Telecommunications Industry Solutions, Washington, DC.

American Forest and Paper Association (AF&PA). 1997. National design specification for wood construction. AF&PA, Washington, DC.

American Lumber Standard Committee, Inc. (ALSC) 1999. American softwood lumber standard PS 20. ALSC, Germantown, MD.

American Society of Agricultural Engineers (ASAE). 1978. Design properties of round, sawn and laminated preservative treated construction poles. EP 388. ASAE, St. Joseph, MI.

American Society for Testing and Materials (ASTM). 1996. Standard practices for establishing stress grades for structural members used in log buildings. ASTM D 3957. ASTM, West Conshohocken, PA.

_____. 1999. Standard specifications for round timber piles. ASTM D 25-99. ASTM, West Conshohocken, PA.

_____. 2000. Standard specification and test method for establishing recommended design stresses for round timber construction poles. ASTM D 3200-2000. ASTM, West Conshohocken, PA.

_____. 2001. Standard practice for establishing allowable stresses for round timber piles. ASTM D 2899-01. ASTM, West Conshohocken, PA.

Bendtsen, B.A. and J. Senft. 1986. Mechanical and anatomical properties in individual growth rings of plantation-grown eastern cottonwood and loblolly pine. Wood and Fiber Sci. 18(1):23-38.

Bodig, J. and C.G. Arnette. 2000. In-grade testing of Douglas-fir timber piles. Western Wood Prod. Industry, EDM, Ft. Collins, CO.

Doyle, D.V. and L.J. Markwardt. 1966. Properties of southern pine in relation to strength grading of dimension lumber. Res. Pap. FPL-RP-64. USDA Forest Serv., Forest Prod. Lab., Madison, WI.

Gerhards, C.C. 1972. Relationship of tensile strength of southern pine dimension lumber to inherent characteristics. Res. Pap. FPL-RP-174. USDA Forest Serv., Forest Prod. Lab., Madison, WI.

Newlin, J.A. and G.W. Trayer. 1924. Form factors of beams subjected to transverse loading. Rept. 181 to National Advisory Committee for Aeronautics. Reprinted October 1941 as Rept. 1310. USDA Forest Serv., Forest Prod. Lab., Madison, WI.

Pearson, R.G. and R.C. Gilmore. 1971. Characterization of the strength of juvenile wood of loblolly pine (*Pinus taeda* L.). Forest Prod. J. 21(1):23-31.

Tuomi, R.L., R.W. Wolfe, R.C. Moody, and F.W. Muchmore. 1979. Bending strength of large Alaskan Sitka spruce and western hemlock log bridge stringers. FPL-RP-34. USDA Forest Serv., Forest Prod. Lab., Madison, WI.

VTT Technical Research Center of Finland (VTT). 1999. Round small-diameter timber for construction. A. Ranta-Maunus, ed. Project CT 96-0091. VTT, Espoo, Finland.

Wolfe, R.W., J.R. King, and A. Gjinolli. 2000. Dowel-nut connection in Douglas-fir peeler cores. FPL-RP-586. USDA Forest Serv., Forest Prod. Lab., Madison, WI.

Wood, L.W. and L.J. Markwardt. 1965. Derivation of fiber stress from strength values of wood poles. FPL-RP-39. USDA Forest Serv., Forest Prod. Lab., Madison, WI.

_____, E.C.O. Erickson, and A.W. Dohr. 1960. Strength and related properties of wood poles. ASTM, West Conshohocken, PA.

Appendix. Standard dimension vs. round section properties.

Section properties for rectangular and round sections, 9 inch (228 mm) diameter, with same diagonal (diameter).

<i>b</i>	<i>h</i>	<i>D</i> ^a	<i>A</i>	<i>S</i>	<i>I</i>	<i>A</i> _o	<i>S</i> _o	<i>I</i> _o	<i>AR</i>	<i>SR</i>	<i>IR</i>
1.5	3.5	3.81	5.3	3.1	5.4	11.4	5.4	10.3	2.2	1.8	1.9
1.5	4.5	4.74	6.8	5.1	11.4	17.7	10.5	24.9	2.6	2.1	2.2
1.5	5.5	5.70	8.3	7.6	20.8	25.5	18.2	51.8	3.1	2.4	2.5
2.5	3.5	4.30	8.8	5.1	8.9	14.5	7.8	16.8	1.7	1.5	1.9
1.5	7.25	7.40	10.9	13.1	47.6	43.0	39.8	147.5	4.0	3.0	3.1
3.5	3.5	4.95	12.3	7.1	12.5	19.2	11.9	29.5	1.6	1.7	2.4
2.5	5.5	6.04	13.8	12.6	34.7	28.7	21.6	65.4	2.1	1.7	1.9
3.5	4.5	5.70	15.8	11.8	26.6	25.5	18.2	51.8	1.6	1.5	2.0
2.5	7.25	7.67	18.1	21.9	79.4	46.2	44.3	169.8	2.5	2.0	2.1
3.5	5.5	6.52	19.3	17.6	48.5	33.4	27.2	88.7	1.7	1.5	1.8
4.5	4.5	6.36	20.3	15.2	34.2	31.8	25.3	80.5	1.6	1.7	2.4
3.5	7.25	8.05	25.4	30.7	111.1	50.9	51.2	206.2	2.0	1.7	1.9
5.5	5.5	7.78	30.3	27.7	76.3	47.5	46.2	179.7	1.6	1.7	2.4
5.5	7.25	9.10	39.9	48.2	174.7	65.0	74.0	336.6	1.6	1.5	1.9

^aSection diagonal $D = \sqrt{(b^2 + h^2)}$.