

GEOMETRIC MODEL FOR SOFTWOOD TRANSVERSE THERMAL CONDUCTIVITY. PART I

Hong-mei Gu,

Post-Doctoral Research Associate
USDA Forest Products Laboratory
Madison, WI

and

Audrey Zink-Sharp

Associate Professor
230 Cheatham Hall-0323
Department of Wood Science & Forest Products
Virginia Polytechnic Institute & State University
Blacksburg, VA 24061

(Received April 2002)

ABSTRACT

Thermal conductivity is a very important parameter in determining heat transfer rate and is required for development of drying models and in industrial operations such as adhesive cure rate. Geometric models for predicting softwood thermal conductivity in the radial and tangential directions were generated in this study based on observation and measurements of wood structure. Modeling effective thermal conductivity in the radial and tangential directions is helpful in understanding the heat transfer mechanism in the two directions and predicting the values for a wide range of moisture contents (MC) when practical experiments for obtaining those values are unrealistic. Theoretical estimations indicate that radial thermal conductivity of softwood species is greater than tangential thermal conductivity when the MC is below the fiber saturation point (FSP) due to structure differences in the two directions. A linear relationship was found between MC and radial thermal conductivity in the range of 0%–30%. Both radial and tangential thermal conductivity increases with an increase in latewood percentage. When MC is above the FSP, tangential and radial thermal conductivity increases dramatically and nonlinearly with moisture content. However, no significant difference was found between radial and tangential thermal conductivity above the FSP. Geometric differences in the two directions had little effect on the model-estimated thermal conductivity when free water occupied a portion of the cell lumen.

Keywords: Transverse thermal conductivity, heat transfer, geometric thermal conductivity model.

INTRODUCTION

Wood is a porous material with good insulating properties. Wood's low thermal conductivity and good strength make it of special interest for building construction, refrigeration, automobile applications, and cooperage, among others (Ward 1960). Softwood structure mainly consists of thick-walled latewood tracheids and thin-walled earlywood tracheids aligned in a longitudinal direction parallel to the tree stem. Wood ray cells extend in the radial-transverse direction. Therefore, it is the cell structure of

wood that makes it an anisotropic material. Many of the material properties of wood, including thermal conductivity, are structure-dependent. For example, thermal conductivity varies with the direction of heat flow with respect to the grain. Theoretical models for examining the relationship between wood structure and thermal conductivity have been proposed (Kollmann and Malmquist 1956; Siau et al. 1968; Couturier et al. 1996), but values for wood thermal conductivity in the three directions—longitudinal, radial, and tangential—have not

been modeled. In addition, no prediction of the thermal conductivity change with structure and moisture content has been available prior to this study.

Thermal conductivity of wood is usually measured by the steady-state method, which generally requires some time for wood samples to reach equilibrium. If the samples have high moisture content, it will take a fairly long time for the moisture distribution to reach the equilibrium state. Therefore, it is unrealistic to measure thermal conductivity of high moisture wood samples with the current experimental methods. With the help of theoretical modeling, it will be possible to predict the change of thermal conductivity throughout an extended range of moisture contents. Knowledge of thermal conductivity in a large range of moisture contents is important for kiln-drying operations, hot-pressing of wood-based composites, thermal degradation, and other processes in which wood is subjected to a temperature change.

BACKGROUND

Anatomical structure differences of softwood species in the three orthogonal directions have been studied thoroughly (Haygreen and Bowyer 1982; Hoadley 1980). The majority components of softwood species are long, slender cells called longitudinal tracheids. Tracheids that are formed early in a growing season are thin-walled cells with larger diameters, while those formed later in the year are thick-walled cells with smaller diameters. Tracheids give softwoods the mechanical strength required (especially the thick-walled latewood tracheids) and provide for heat and mass transport. Heat transfer in wood is mainly by conduction through cell walls, and partly by convection of air in cell lumens.

Thermal conductivity, k , is expressed in terms of quantity of heat, Q , that flows across unit thickness, x , of a material with a unit cross-section, A , under unit temperature difference between the two faces, T , in unit time, t :

$$k = \frac{Q * x}{A * T * t} \quad (1)$$

Thermal conductivity of wood has been shown to relate to the structure and moisture content. Wangaard (1940, 1943) tried to predict thermal conductivity on the basis of specific gravity and moisture content from his experimental results with several wood species. A linear relationship between thermal conductivity and density of wood was found by Van Dusen (1920), Rowley (1933), MacLean (1941), and Urakami and Kukuyama (1981). Significant variables affecting the rate of heat flow in wood were found to be: 1) density, 2) moisture content, 3) direction of heat flow with respect to the grain, and 4) relative density of latewood and earlywood and proportion of latewood and earlywood.

Influence of the grain orientation on thermal conductivity has been examined (Griffiths and Kaye 1923; Wangaard 1940; MacLean 1941; Hendricks 1962; Suleiman et al. 1999). Conductivity in the longitudinal direction was found to be about 2.25 to 2.75 times the transverse conductivity. Griffiths and Kaye (1923) found thermal conductivity in the radial direction to be about 5% to 10% greater than in the tangential direction. According to Steinhagen's (1977) review, it appears that the ratio of tangential to radial conductivity is primarily determined by the volume of ray cells in hardwoods and by the latewood volume in softwoods.

Investigations on wood thermal conductivity for the past 80 years have provided empirical models for predicting thermal conductivity from density or specific gravity, moisture content, and temperature. Some theoretical models were based on a single cell's structure (Kollmann and Malmquist 1956; Siau 1995; Siau et al. 1968; Couturier et al. 1996), without considering the macro-structure of wood such as cell arrangement and earlywood/latewood interaction. Also, the models did not differentiate for different directions of wood structure.

EXPERIMENTAL RESEARCH ON ANATOMICAL STRUCTURE

Due to the anisotropic character of wood created by the structure differences in different directions, the purpose of this part of the study was

to quantify the general structure differences in the radial and tangential directions. Two softwoods—southern yellow pine (*Pinus spp.*) and Scots pine (*P. sylvestris*)—were selected because they are the most popular construction lumber types in the United States and Europe. Two to four 6- \times 6- \times 6-mm cubes with smooth, clear cross-sections were cut from each species. Sample cubes were subjected to conventional oven-drying to remove all moisture before the scanning electron microscope (SEM) observations that required completely dry samples to work in the vacuum environment. To compare cell-wall percentage on the cross-section between dry and wet samples, saturated Scots pine sample cubes were examined using a Philips XL30-Field Emission Environmental SEM (FE-SEM). This ESEM equipment eliminates the need for a high vacuum in the microscope chamber of conventional SEMs, and it allows observation in a normal environment, i.e., in a humid atmosphere with normal air pressure. So, cell-wall thickness on the cross-section could be measured under the “original” wet condition to compare with dry samples.

Twenty SEM images were collected from each species, 10 of which were from the latewood area (Fig. 1A), and the other 10 were from the earlywood area (Fig. 1B). Wet sample images were collected using the ESEM and Scots pine samples (Figs. 2A and 2B).

It can be clearly shown from the images that the cells are aligned nearly perfectly in the radial direction with several small rays between the aligned tracheids. The cells are less systematic in the tangential direction. If one randomly draws a line in the tangential direction across the image, there is no one single line that crosses cell wall only. It will always cross cell wall and cell lumen alternately. But in the radial direction, there is a part of the image with full cell walls running through whole radial lines (this would be vertical lines on the image). This part is the side walls of radially aligned cells.

Microscopic images were loaded into an image analysis software program for measurement. Ten random lines were drawn on each image horizontally and vertically where a horizontal direction in the image corresponds to the tangential direction of wood and vertical direction corresponds to the radial direction. Cell-wall percentages in the radial and tangential direction for the two softwood species were measured, averages calculated, and values are shown in Table 1. Side-wall percentages in the radial direction were also measured and shown in this table. Each result was averaged from 50 (for Scots pine) or 100 (for southern yellow pine) measurements. The large number of the data measured provides confidence to assume a normal distribution for these data. Therefore, statistical ANOVA can be applied to examine differ-

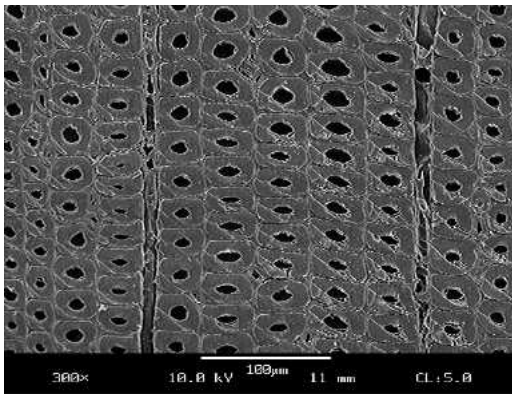

A

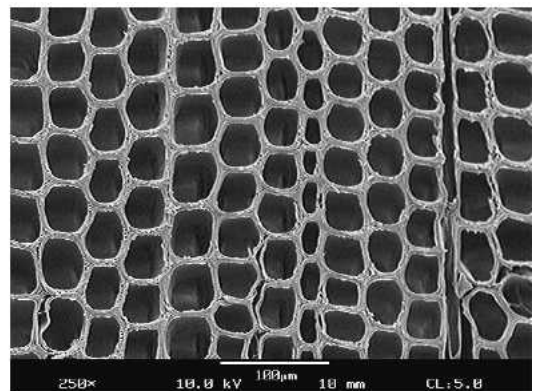

B

FIG. 1. Southern yellow pine images. A-latewood, B-earlywood.

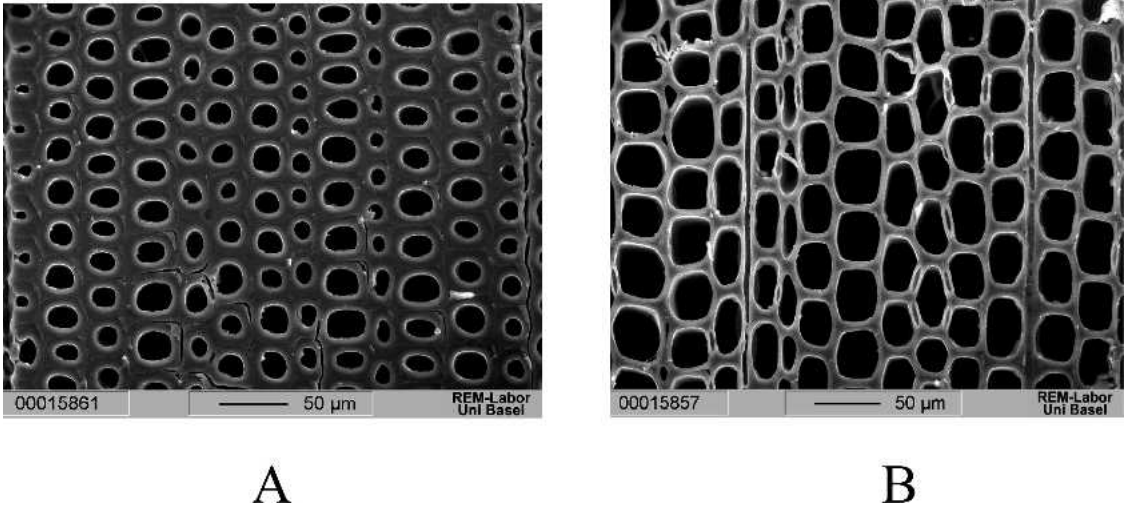

Fig. 2. Scots pine images, wet condition. A-latewood, B-earlywood.

ences between species, between earlywood and latewood, and between the radial and tangential direction.

Generalized random block design (GRBD) statistical analysis showed that the cell-wall percentages in the tangential direction were significantly greater than the cell-wall percentages in the radial direction for both earlywood and latewood in the two softwood species. If there is a difference for the cell-wall substance in the radial and tangential directions, the heat transfer property—thermal conductivity—may show differences in the two directions too, because heat transport in wood mainly takes place through the cell-wall part. No significant differences between the cell-wall percentages in the two softwood species were found.

Cell-wall substance will be swollen if there is moisture in wood. A randomized complete block design (with subsamplings) model was used to examine differences in cell-wall percentages between dry and wet samples. No significant difference between dry and wet samples for the cell-wall percentage in latewood area was found. But, there is significant difference between the two sets of data for the earlywood cell-wall percentage. This is explained by the fact that latewood cells are small in diameter with thick walls and small lumens, but the earlywood cells are

bigger and have very thin walls and much bigger lumens. Although thick walls may give latewood cells more swelling than the thin-walled cells, the less void or lumen space in the latewood area prevents the swelling. While the thinner cell walls of the earlywood tracheids may not be able to swell by themselves as much as the latewood tracheids, they can be forced to some extent to swell with their neighbors—latewood tracheids. And the large lumens provide the space for the cell walls to swell. So, the cell walls in the earlywood were significantly increased for the wet samples. Consequently, in the model estimation process described in the next section, the cell-wall percentage parameters required as model inputs must be different for the dry wood model and the wet wood model since they are significantly different.

ANALYTICAL RESEARCH ON WOOD TRANSVERSE THERMAL CONDUCTIVITY MODELING

Geometric models for thermal conductivity in the radial and tangential directions proposed in this study were based on consideration of earlywood/latewood percentage and arrangement and cell-wall percentage and arrangement in the two directions. Latewood percentage and cell-wall percentage are the two major contributing factors to specific gravity of wood. Inclusion of

these two components in the model made it a closer representation of the wood structure influence on the properties than the previous models proposed by Kollmann and Malmquist (1956) and Siau et al. 1968. In those models, only single cells were chosen as the structure basis for the geometric model.

Since the microscopic structure of softwoods does not vary greatly from species to species, except for inclusion of resin canals in some species (Haygreen and Bowyer 1982; Panshin and deZeeuw 1980, among others), the parameters were not statistically different as demonstrated in microscopic tests fully described in Gu (2001). Therefore, the model-estimated thermal conductivity should be the same for both species.

Model development

Geometric models were set up based on the microscopic observations. Assumptions made for the models are:

- Heat transfer path in the two directions is represented by cell wall, cell lumen arrangement and amount, and percentage in the two directions.
- Shrinkage/swelling in the cell wall is not considered in the model until reaching the FSP. Cell-wall percentage is assumed constant below FSP. When FSP (MC of 30%) is reached, cell-wall percentages are increased to new values for both radial and tangential directions due to full saturation of bound water in the cell wall.
- Earlywood/latewood are separated for heat transport in the geometric models due to the different cell-wall amount in earlywood and latewood.

A simplified model structure for softwoods is

shown in Fig. 3. Notice in Fig. 3 that earlywood and latewood are arranged in parallel for the tangential direction and in series for the radial direction. The total cell-wall percentages in the radial and tangential direction for both earlywood and latewood are given by microscopic measurement tests (Table 1). Within earlywood and latewood, cell wall and cell lumen were arranged in series for the tangential direction and side walls were arranged in parallel with the series layout of the cross walls (top and bottom walls of cells) and cell lumen. The subsequent analytical model for transverse thermal conductivity is based on the simplified structure as seen in Fig. 3.

An example illustration of the moisture change in a single cell is shown in Fig. 4. There are 3 states for water existing in wood: bound water, water vapor, and free water. When wood is under oven-dry condition, there is no moisture in the wood. Below FSP, moisture exists as bound water in the cell walls and vapor in the cell lumens. FSP is when bound water is occupying all the possible hydrogen-bonding sites in the cell wall and cell lumens are full of saturated water vapor, but there is no free water in the lumen. When MC is over the FSP, some free water will appear in the lumens. When the lumen is filled with all the free water, the maximum MC is reached. When free water takes part of the cell lumens, there will be significant change in the estimated effective thermal conductivity in both directions because water has a much greater thermal conductivity value than air and vapor. Since the arrangement of free water and vapor in the cell lumen is difficult to model due to the surface tension between free water and vapor, a mixture of free water and vapor is assumed to exist in the cell lumen. The weighted average of free water thermal conductivity and air/vapor conductivity values in the lumen is

TABLE 1. *Cell-wall percentages.*

	Earlywood cell wall			Latewood cell wall		
	Radial	Tangential	Side walls	Radial	Tangential	Side walls
Southern yellow pine	16.49%	31.50%	15.94%	44.37%	66.94%	50.77%
Scots pine	13.69%	31.46%	13.50%	52.98%	71.51%	50.83%

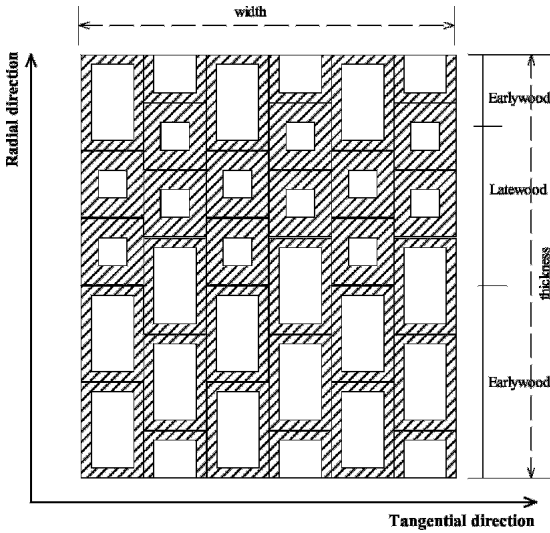

FIG. 3. Simplified structure model for softwoods.

used in the geometric models for MC over the FSP. Geometric models for wet softwood samples (with MC above the FSP) are the same as the ones for MC below FSP, except the pure vapor thermal conductivity is replaced by the weighted average thermal conductivity in the cell lumen.

The percentage of air and/or vapor in the cell lumen can be calculated based on Siau's (1995) wood porosity (V_a) definition:

$$V_a = 1 - G \left(\frac{1}{G_0^w} + 0.01MC \right) \quad (2)$$

where, G is specific gravity;

G_0^w is oven-dry cell-wall specific gravity, = 1.53;

MC is moisture content (%);

V_a is calculated based on total volume V of wood. According to Gong (1992), to base V_a on the volume of cell lumen, it must be multiplied by V/V_{lumen} , which is the inverse of V_a at $MC = 0$. So,

$$V_l = \frac{1 - G \left(\frac{1}{G_0^w} + 0.01MC \right)}{1 - G \frac{1}{G_0^w}} \quad (3)$$

This V_l is the percentage of porosity (contains air and vapor) in the cell lumen at certain MC above FSP. The fraction for the free water in the lumen will be:

$$V_{fw} = 1 - V_l \quad (4)$$

The weighted average of thermal conductivity for vapor and free water in the cell lumen is:

$$k_{aw} = V_l * k_a + (1 - V_l) * k_w \quad (5)$$

where k_a , k_w , are known thermal conductivity of air/vapor and water; $k_a = 0.046 \text{ W/m} \cdot \text{K}$ (Maku 1954); $k_w = 0.59 \text{ W/m} \cdot \text{K}$ (Siau 1995).

Theoretical derivation of thermal conductivity

Thermal resistance model.—An analogous electrical resistance system can be applied to derive the overall thermal conductivity as a resultant value from the known thermal conductivities of its substances. Thermal resistance models for radial and tangential directions generated from the geometric models are shown in Fig. 5.

Introducing the electrical conductance defini-

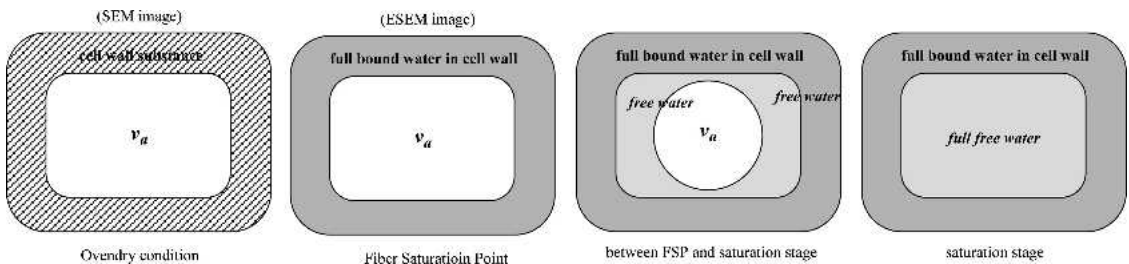

FIG. 4. Single cell structure change from dry to fully saturated condition.

tion into the thermal system gives the thermal conductance as:

$$g = k \frac{A}{L} \quad (6)$$

where, g is thermal conductance, W/K;

k is thermal conductivity, W/m · K;

A is cross-section of the heat flow, m²;

L is length of the heat flow, m.

Thermal resistance (R) is the inverse of the thermal conductance:

$$R = \frac{1}{g} = \frac{L}{kA} \quad (7)$$

Tangential thermal conductivity derivation.—

According to overall electrical resistance calculation in parallel systems (earlywood and latewood are in parallel for the tangential direction, see Figs. 3 and 5a), the effective thermal conductivity in tangential direction is calculated by:

$$\frac{1}{R_{T,eff}} = \frac{1}{R_{Ew}} + \frac{1}{R_{Lw}} \quad (8)$$

where, $R_{T,eff}$ is total effective thermal resistance in tangential direction;

R_{Ew} is total thermal resistance from the earlywood part;

R_{Lw} is total thermal resistance from the latewood part.

Within the earlywood or latewood area, cell-wall substance and air in the lumens are arranged in series. So for a series system, total thermal resistance is calculated by:

$$\begin{aligned} R_{Ew} &= R_{Ew,wall} + R_{Ew,air} \\ R_{Lw} &= R_{Lw,wall} + R_{Lw,air} \end{aligned} \quad (9)$$

where, $R_{Ew,wall}$ is resistance from earlywood cell-wall substance;

$R_{Ew,air}$ is resistance from air in earlywood cell lumen;

$R_{Lw,wall}$ is resistance from latewood cell-wall substance;

$R_{Lw,air}$ is resistance from air in latewood cell lumen.

By the definition and anatomical measurement results, each of these resistances can be calculated by:

$$R_{Ew,wall} = \frac{TEwD * L}{k_c * Ew * A}; \quad (10a)$$

$$R_{Ew,air} = \frac{(1 - TEwD) * L}{k_a * Ew * A}; \quad (10b)$$

$$R_{Lw,wall} = \frac{TLwD * L}{k_c * Lw * A}; \quad (11a)$$

$$R_{Lw,air} = \frac{(1 - TLwD) * L}{k_a * Lw * A}; \quad (11b)$$

$$R_{T,eff} = \frac{L}{k_{T,eff} * A} \quad (12)$$

where, k_c is thermal conductivity of cell-wall substance = 0.41 W/m · K (Maku 1954)

$TEwD$ is cell-wall percentage in tangential direction of earlywood dry sample;

Ew is earlywood percentage measured in wood samples;

$TLwD$ is cell-wall percentage in tangential direction of latewood dry sample;

Lw is latewood percentage measured in wood samples.

By inserting all these resistances into Eq. (9) then Eq. (8), the effective tangential thermal conductivity for the dry softwood samples can be calculated.

For the wet sample model (MC above FSP), thermal resistance in the cell lumen is assumed to be a mixture of vapor and free water. Total thermal resistance in the tangential direction is calculated the same as derived above. The only difference in the thermal resistance from the cell lumen is the weighted average thermal conductivity of vapor and water instead of pure air/vapor thermal conductivity value. The cell-wall percentages in earlywood and latewood are slightly different as provided in Table 1 for wet samples.

Radial thermal conductivity derivation.—

With the series arrangement of earlywood and latewood in the radial direction (see Fig. 3 and

Fig. 5B), the total effective thermal resistance in the radial direction is:

$$R_{R,eff} = R_{Ew} + R_{Lw} \quad (13)$$

Within a radial earlywood or latewood area, the thermal resistance arrangement is more complicated than in the tangential direction. Part of the cell walls (side walls) are arranged in parallel with the series arrangement of the other part of cell wall (cross walls) and air in cell lumen. So the resistances from earlywood and latewood are:

$$\frac{1}{R_{Ew}} = \frac{1}{R_{Ew,side\ wall}} + \frac{1}{R_{Ew,air} + R_{Ew,cross\ wall}}$$

$$\frac{1}{R_{Lw}} = \frac{1}{R_{Lw,side\ wall}} + \frac{1}{R_{Lw,air} + R_{Lw,cross\ wall}} \quad (14)$$

where, $R_{Ew,side\ wall}$ is resistance from earlywood side walls;

$R_{Ew,air}$ is resistance from air in earlywood cell lumens;

$R_{Ew,cross\ wall}$ is resistance from earlywood cross walls;

$R_{Lw,side\ wall}$ is resistance from latewood side walls;

$R_{Lw,air}$ is resistance from air in latewood cell lumens;

$R_{Lw,cross\ wall}$ is resistance from latewood cross walls.

By definition and anatomical measurement results, each of these resistances can be calculated:

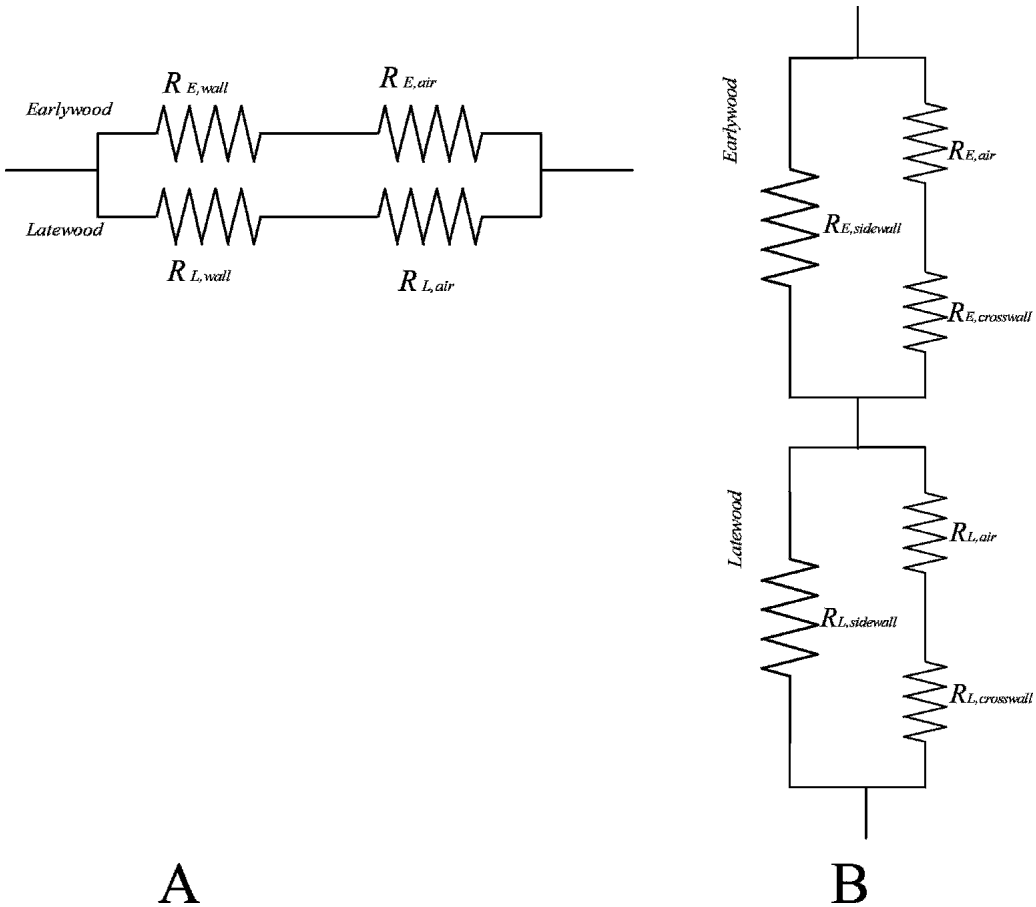

FIG. 5. Thermal resistance model for softwood species. A-tangential direction, B-radial direction.

$$R_{Ew, sidewall} = \frac{Ew * L}{k_c * SEwRD * A}; \quad (15a)$$

$$R_{Ew, air} = \frac{Ew * (1 - CEwRD) * L}{k_a * (1 - SEwRD) * A}; \quad (15b)$$

$$R_{Ew, crosswall} = \frac{Ew * CEwRD * L}{k_c * (1 - SEwRD) * A}; \quad (15c)$$

$$R_{Lw, sidewall} = \frac{Lw * L}{k_c * SLwRD * A}; \quad (16a)$$

$$R_{Lw, air} = \frac{Lw * (1 - CLwRD) * L}{k_a * (1 - SLwRD) * A}; \quad (16b)$$

$$R_{Lw, crosswall} = \frac{Lw * CLwRD * L}{k_c * (1 - SLwRD) * A}; \quad (16c)$$

$$R_{R, eff} = \frac{L}{k_{R, eff} * A} \quad (17)$$

where, *SEwRD* is side wall percentage in earlywood radial direction of dry sample;

CEwRD is cross wall percentage in earlywood radial direction of dry sample;

SLwRD is side wall percentage in latewood radial direction of dry sample;

CLwRD is cross wall percentage in latewood radial direction of dry sample;

All these parameters were obtained from the anatomical tests in the previous section. The effective radial thermal conductivity for dry wood samples can be obtained using Eq. (14) then Eq. (13). For MC above FSP, the derivation is the same, except the thermal resistance from cell lumen is taken from the mixture of vapor and water instead of pure air/vapor.

Numerical results for the model estimation

Estimation of thermal conductivity below FSP.—Since the two species have similar structure parameters and the same models, estimations of thermal conductivity are the same for both species. Thermal conductivities in the two directions were performed in *Mathematica* software based on the resistance models and derivations described above. Since the latewood (or earlywood) percent on the cross-section may vary from sample to sample, the program esti-

mated *k* values for latewood% ranging from 1% to 99%. Thermal conductivity value for air (k_a) in the lumen is set as a constant of 0.046 W/m · K, while thermal conductivity value for the cell-wall substance k_c is defined as a function of moisture content based on the relationship given by Siau (1995):

$$k_{qT} = G (0.2 + 0.0038 * MC) + 0.024 \quad [W/m \cdot K] \quad \text{for } MC < 40\% \quad (18)$$

where, k_{qT} —the transverse thermal conductivity;
G—specific gravity.

If $k_c = 0.41$ W/m · K is the assumed value (Maku 1954) at the oven-dry condition (MC = 0%), and the specific gravity of the cell wall at the oven-dry condition is 1.45 (Kellogg and Wangaard 1969), then the k_c as a function of MC can be simplified as:

$$k_c = 0.41 + 0.0055 * MC \quad \text{for } MC \leq 30\% \quad (19)$$

Above the FSP (30%), k_c values will stay constant because cell-wall composition does not change when MC is over FSP.

Estimation values for thermal conductivity of southern yellow pine are shown in Table 2 (tangential direction) and Table 3 (radial direction). Two-dimensional plots for the radial and tangential thermal conductivity changes with MC and latewood percent in the sample are shown in Figs. 6 and 7.

From the tables and figures, it can be seen that there is a significant difference for model-predicted thermal conductivity values between the radial and tangential directions. Radial thermal conductivity is higher than the tangential values. Latewood (LW) percentage has a substantial effect on the transverse thermal conductivities. This is consistent with previous literature results.

Tangential thermal conductivity (TTC) is predicted to change linearly with LW percent, but change insignificantly with MC. Radial thermal conductivity (RTC) changes linearly with MC, and non-linearly with LW percentage. RTC is an inverse function of earlywood percentage (earlywood% = 1-latewood%), which gives the

TABLE 2. Model-predicted tangential thermal conductivity values for latewood percentages from 10% to 99% and MC from 0% to 30%.

Latewood percentage	Moisture content									
	0%	5%	10%	11%	12%	13%	14%	15%	20%	30%
10%	0.0688	0.0691	0.0694	0.0695	0.0695	0.0696	0.0696	0.0697	0.0699	0.0703
20%	0.0738	0.0742	0.0746	0.0747	0.0747	0.0748	0.0749	0.0749	0.0753	0.0758
30%	0.0788	0.0793	0.0798	0.0799	0.0800	0.0801	0.0801	0.0802	0.0806	0.0813
40%	0.0837	0.0844	0.0850	0.0851	0.0852	0.0853	0.0854	0.0855	0.0860	0.0868
45%	0.0862	0.0869	0.0876	0.0877	0.0878	0.0879	0.0880	0.0881	0.0887	0.0896
50%	0.0887	0.0895	0.0902	0.0903	0.0904	0.0905	0.0907	0.0908	0.0913	0.0923
55%	0.0912	0.0920	0.0927	0.0929	0.0930	0.0932	0.0933	0.0934	0.0940	0.0951
60%	0.0937	0.0945	0.0953	0.0955	0.0956	0.0958	0.0959	0.0961	0.0967	0.0979
70%	0.0986	0.0996	0.1005	0.1007	0.1009	0.1010	0.1012	0.1013	0.1021	0.1034
80%	0.1036	0.1047	0.1057	0.1059	0.1061	0.1063	0.1064	0.1066	0.1074	0.1089
90%	0.1086	0.1098	0.1109	0.1111	0.1113	0.1115	0.1117	0.1119	0.1128	0.1144
99%	0.1130	0.1144	0.1156	0.1158	0.1160	0.1162	0.1164	0.1166	0.1176	0.1194

TABLE 3. Model-predicted radial thermal conductivity values for latewood percentages from 10% to 99% and MC from 0% to 30%.

Latewood percentage	Moisture content									
	0%	5%	10%	11%	12%	13%	14%	15%	20%	30%
10%	0.1171	0.1219	0.1267	0.1276	0.1286	0.1295	0.1305	0.1315	0.1362	0.1458
20%	0.1243	0.1295	0.1347	0.1358	0.1368	0.1378	0.1389	0.1399	0.1451	0.1554
30%	0.1325	0.1382	0.1439	0.1450	0.1461	0.1472	0.1484	0.1495	0.1552	0.1664
35%	0.1370	0.1430	0.1489	0.1501	0.1513	0.1525	0.1536	0.1548	0.1607	0.1725
40%	0.1418	0.1481	0.1543	0.1556	0.1568	0.1580	0.1593	0.1605	0.1667	0.1791
45%	0.1470	0.1536	0.1601	0.1614	0.1628	0.1641	0.1654	0.1667	0.1732	0.1862
50%	0.1525	0.1595	0.1664	0.1678	0.1692	0.1706	0.1719	0.1733	0.1802	0.1939
55%	0.1586	0.1659	0.1732	0.1747	0.1761	0.1776	0.1790	0.1805	0.1878	0.2022
60%	0.1650	0.1728	0.1806	0.1821	0.1837	0.1852	0.1868	0.1883	0.1960	0.2113
70%	0.1798	0.1886	0.1974	0.1991	0.2009	0.2026	0.2044	0.2061	0.2149	0.2322
80%	0.1974	0.2075	0.2176	0.2196	0.2217	0.2237	0.2257	0.2277	0.2377	0.2577
90%	0.2188	0.2307	0.2425	0.2449	0.2472	0.2496	0.2519	0.2543	0.2660	0.2895
99%	0.2425	0.2564	0.2703	0.2731	0.2758	0.2786	0.2814	0.2841	0.2980	0.3256

trend as the lower the earlywood percentage (higher latewood percentage), the higher the RTC, and the increase of RTC is greater with the decrease of earlywood percentage (corresponding to the increase of latewood percentage). The ratio for RTC over TTC is basically controlled by the RTC because RTC is much greater than and changes more significantly than TTC. The ratio ranges from 1.2 to 2.5 for the whole range shown in Fig. 8.

Estimation of thermal conductivity above FSP.—Although the models are the same for wet and dry wood thermal conductivity, some parameters such as the anatomical structure parameters, are different for wet wood calculations.

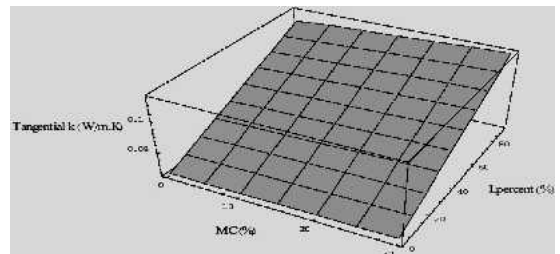

FIG. 6. Model-predicted tangential thermal conductivity values for latewood percentages from 10% to 99% and MC from 0% to 30%.

The maximum moisture content that Scots pine can have under the fully saturated condition was calculated by the equation given by Siau (1995):

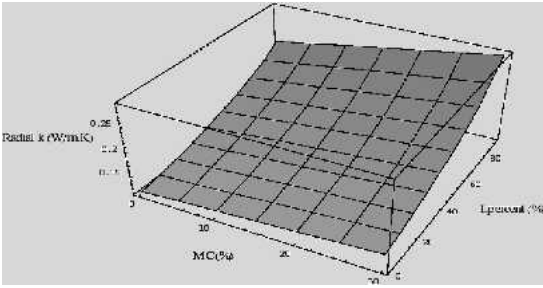

FIG. 7. Model-predicted radial thermal conductivity values for latewood percentages from 10% to 99% and MC from 0% to 30%.

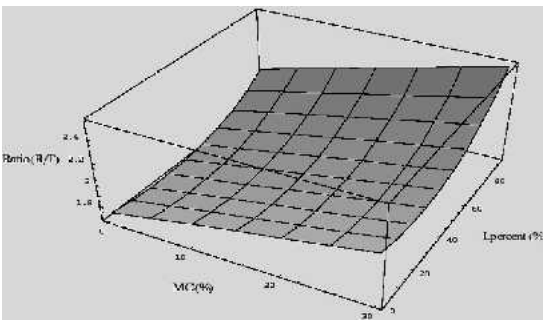

FIG. 8. Model-predicted ratio of radial versus tangential thermal conductivity values.

$$MC_{max} = \frac{100}{G_{dry}} - 65.3 = 178\% \quad (20)$$

Model outputs are shown in Tables 4 and 5 and Figs. 9–11. Results indicate that tangential thermal conductivity increases dramatically

when free water appears in wood (MC > 30%) as seen in Fig. 9. Above the FSP, the moisture content shows much more impact on the tangential thermal conductivity than it does below the FSP. Before the free water appears, air in the lumen contributes very little to the total effective conductance in the tangential direction. The thermal conductivity of free water is much higher than that of air. Appearance of free water in the lumen increases the total effective conductance in the tangential direction. Moisture content or free water appearance also has a positive influence on the total effective conductance in the radial direction (see Fig. 10), but not as significant as the tangential direction. Thermal conductivity increases nonlinearly with moisture content above the FSP in both radial and tangential directions. Thermal conductivities in the two directions were predicted to be close with the ratio near 1 for MC above FSP.

As seen in Fig. 11, the ratio of the two thermal conductivities predicted by the model in the whole range changed dramatically at the FSP. Below the FSP, the ratio tends to follow the radial thermal conductivity change because radial values and changes are much more significant than the tangential ones. At the FSP, the ratio (R/T) dropped straight down to near 1.0, which means that the tangential thermal conductivity jumps close to the radial thermal conductivity when free water appears in the sample according to the model’s prediction. The thermal

TABLE 4. Model-predicted tangential thermal conductivity values for Scots pine and latewood percentages from 5% to 99% and MC from 0% to maximum 178%.

Latewood percent	Moisture content (%)											
	0%	5%	15%	30%	40%	60%	80%	100%	120%	140%	160%	178%
5%	0.0669	0.0672	0.0677	0.0682	0.2023	0.2789	0.3465	0.4066	0.4606	0.5093	0.5535	0.5900
10%	0.0700	0.0704	0.0710	0.0717	0.2083	0.2848	0.3516	0.4108	0.4636	0.5111	0.5541	0.5895
20%	0.0763	0.0768	0.0776	0.0787	0.2202	0.2966	0.3620	0.4192	0.4697	0.5148	0.5554	0.5886
30%	0.0825	0.0831	0.0843	0.0857	0.2321	0.3083	0.3724	0.4275	0.4757	0.5184	0.5566	0.5877
40%	0.0887	0.0895	0.0909	0.0926	0.2440	0.3201	0.3827	0.4359	0.4818	0.5221	0.5579	0.5868
50%	0.0949	0.0959	0.0976	0.0996	0.2559	0.3318	0.3931	0.4442	0.4879	0.5258	0.5591	0.5859
60%	0.1011	0.1023	0.1042	0.1066	0.2678	0.3436	0.4035	0.4526	0.4939	0.5294	0.5604	0.5850
70%	0.1073	0.1086	0.1109	0.1135	0.2797	0.3553	0.4138	0.4610	0.5000	0.5331	0.5616	0.5842
80%	0.1136	0.1150	0.1175	0.1205	0.2916	0.3671	0.4242	0.4693	0.5061	0.5368	0.5629	0.5833
90%	0.1198	0.1214	0.1242	0.1275	0.3035	0.3789	0.4346	0.4777	0.5121	0.5404	0.5641	0.5824
99%	0.1254	0.1271	0.1301	0.1338	0.3142	0.3894	0.4439	0.4852	0.5176	0.5437	0.5652	0.5816

TABLE 5. Model-predicted radial thermal conductivity values for Scots pine and latewood percentages from 5% to 99% and MC from 0% to maximum 178%.

Latewood percent	Moisture content (%)											
	0%	5%	15%	30%	40%	60%	80%	100%	120%	140%	160%	178%
5%	0.1038	0.1077	0.1155	0.1272	0.2410	0.2998	0.3555	0.4084	0.4587	0.5065	0.5521	0.5913
10%	0.1071	0.1111	0.1193	0.1315	0.2464	0.3052	0.3605	0.4127	0.4620	0.5086	0.5528	0.5907
20%	0.1143	0.1188	0.1277	0.1410	0.2580	0.3166	0.3709	0.4215	0.4687	0.5129	0.5544	0.5895
30%	0.1227	0.1276	0.1374	0.1521	0.2707	0.3288	0.3819	0.4307	0.4756	0.5173	0.5559	0.5884
40%	0.1324	0.1379	0.1488	0.1650	0.2847	0.3420	0.3936	0.4403	0.4828	0.5217	0.5575	0.5873
50%	0.1437	0.1499	0.1621	0.1803	0.3003	0.3564	0.4060	0.4503	0.4902	0.5262	0.5590	0.5861
60%	0.1571	0.1642	0.1781	0.1987	0.3177	0.3720	0.4192	0.4608	0.4978	0.5308	0.5606	0.5850
70%	0.1734	0.1815	0.1975	0.2214	0.3372	0.3890	0.4333	0.4718	0.5056	0.5355	0.5622	0.5839
80%	0.1933	0.2028	0.2218	0.2499	0.3593	0.4076	0.4484	0.4834	0.5137	0.5403	0.5638	0.5827
90%	0.2184	0.2299	0.2528	0.2867	0.3844	0.4281	0.4646	0.4955	0.5220	0.5451	0.5654	0.5816
99%	0.2474	0.2614	0.2892	0.3307	0.4102	0.4485	0.4802	0.5069	0.5298	0.5496	0.5668	0.5806

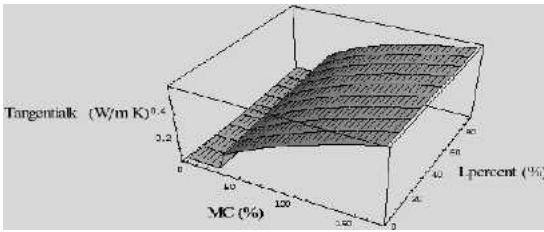

FIG. 9. Tangential thermal conductivity values predicted for Scots pine for latewood percentage from 5% to 99% and MC from 0% to maximum 178%.

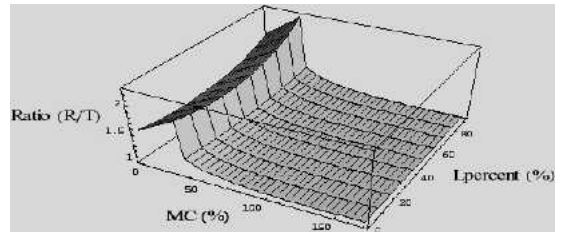

FIG. 11. Ratio of radial versus tangential thermal conductivity values predicted for Scots pine.

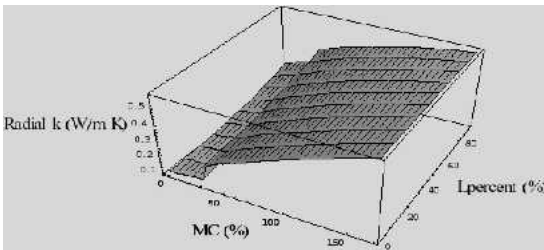

FIG. 10. Radial thermal conductivity values predicted for Scots pine for latewood percentage from 5% to 99% and MC from 0% to maximum 178%.

conductivities in the two directions are not significantly different from each other above the FSP.

SUMMARY AND CONCLUSIONS

Observation of wood anatomical structure of two softwood species gave the basis and requisite parameters to develop geometric and ther-

mal resistance models for radial and tangential thermal conductivity. Results from observation and image analysis measurements showed structural differences between the radial and tangential direction on wood cross-section. Regular (close to square)-shaped cells aligned in the radial direction gave a different arrangement for the cell wall and cell lumen in the radial and tangential direction as described in the models. There is more cell-wall substance in the tangential direction than in the radial direction. Different percentages of cell-wall substance in the radial and tangential direction between the dry and wet condition was also examined.

Because the geometric models developed in this study include earlywood-latewood interaction and cell-wall percentage and arrangement in the two transverse directions, they better represent wood structure than previous models found in the literature. An analogous electrical resistance circuit was applied to generate thermal resistance models. Estimations of radial and tan-

gential thermal conductivities were provided in a wide MC range for different latewood percentages. Comparison of model predictions with experimental values has been completed and is described in a separate paper.

Above the FSP, both tangential and radial thermal conductivity increase dramatically with moisture content changes, but no significant difference was found between the two. Therefore, we conclude that the geometric difference in the two directions has little influence on the thermal conductivities when free water occupies part of the cell lumen.

ACKNOWLEDGMENTS

The authors wish to acknowledge the financial support of U.S. Department of Energy (DOE) project—DE-FC07-97ID13537—Moisture Distribution and Flow During Drying of Wood and Fiber.

REFERENCES

- COUTURIER, M. F., K. GEORGE, M. H. SCHNEIDER. 1996. Thermophysical properties of wood-polymer composites. *Wood Sci. Tech.* 30:179–196.
- GONG, L. 1992. A theoretical numerical and experimental study of heat and mass transfer in wood during drying. Ph.D. Thesis, Dept. of Mechanical and Material Engineering, Washington State University, Pullman, WA.
- GRIFFITHS, E. AND G. W. C. KAYE. 1923. *Proc. Roy. Soc. Lond. Ser. A* 104:71.
- GU, H. M. 2001. Structure-based, two-dimensional anisotropic, transient heat conduction model for wood. Ph.D. Dissertation, Virginia Polytechnic Institute and State University, Blacksburg, VA.
- HAYGREEN, J. G., AND J. L. BOWYER. 1982. *Forest products and wood science: An introduction*. 3rd Ed. Iowa State University Press, Ames, IA.
- HENDRICKS, L. 1962. Thermal conductivity of wood as a function of temperature and moisture content. Thesis, State University College of Forestry at Syracuse University, Syracuse, NY.
- HOADLEY, B. R. 1980. *Identifying wood: Accurate results with simple tools*. The Taunton Press, Newtown, CT.
- KELLOGG, R. M. AND F. F. WANGAARD. 1969. Variation in the cell density of wood. *Wood Fiber* 1:180–204.
- KOLLMANN, F., AND L. MALMQUIST. 1956. Über die Waimeleitzahl von Holz und Holzwerkstoffen. *Holz Roh-Werkst.* 14:201–204.
- PANSHIN, A. J. AND C. DE ZEEUW. 1980. *Textbook of wood technology*. 4th ed. McGraw-Hill Book Company, New York, NY.
- MACLEAN, J. D. 1941. Thermal conductivity of wood. *Heating, Piping and Air Conditioning* 13:380–391.
- MAKU, T. 1954. Studies on the heat conduction in wood. *Wood Res. Bull.* 13:1–80. Kyoto University, Kyoto, Japan.
- ROWLEY, F. B. 1933. The heat conductivity of wood at climatic temperature differences. *Heating, Piping, and Air Conditioning* 5:313–323.
- SIAU, J. F. 1995. *Wood: Influence of moisture on physical properties*. Department of Wood Science and Forest Products, Virginia Tech., Blacksburg, VA.
- , R. W. DAVIDSON, J. A. MEYER, AND C. SKAAR. 1968. A geometrical model for wood-polymer composites. *Wood Science* 1(2):116–128.
- STEINHAGEN, H. P. 1977. Thermal properties of wood, green or dry, from -40°C to $+100^{\circ}\text{C}$: A literature review. USDA Forest Service General Tech. Rept. FPL-9, Forest Products Laboratory, Madison, WI.
- SULEIMAN, B. M., J. B. LARGELDT, AND M. GUSTAVSSON. 1999. Thermal conductivity and diffusivity of wood. *Wood Sci. Technol.* 33:465–473.
- URAKAMI, H. AND M. KUYUYAMA. 1981. The influence of specific gravity on thermal conductivity of wood. *Bull. Kyoto Prefect Univ. For.* 25:38–45.
- VAN DUSEN, M. S. 1920. The thermal conductivity of heat insulators. *J. Am. Soc. Heat. Vent. Eng.* 26:625–656.
- WANGAARD, F. F. 1940. Transverse heat conductivity of wood. *Heating, Piping and Air Conditioning.* 12:459–464.
- , 1943. The effect of wood structure upon heat conductivity. *Transactions of the A.S.M.E.* February, 1943: 127–135.
- WARD, R. J. 1960. A dynamic method for determining specific heat and thermal conductivity of wood based materials as a function of temperature. Thesis, State University College of Forestry at Syracuse University, Syracuse, NY.