

TECHNICAL NOTE NUMBER 242

FOREST PRODUCTS LABORATORY
MADISON, WISCONSIN

UNITED STATES FOREST SERVICE
AUGUST, 1940

PICTURED GOOD AND POOR PRACTICE IN FRAME HOUSE CONSTRUCTION DETAILS

The following sketches, which are self explanatory, were taken from U. S. Department of Agriculture Farmers' Bulletin No. 1756, "Selection of Lumber for Farm and Home Building," which can be obtained from the Superintendent of Documents, Washington, D. C., for 5 cents per copy.

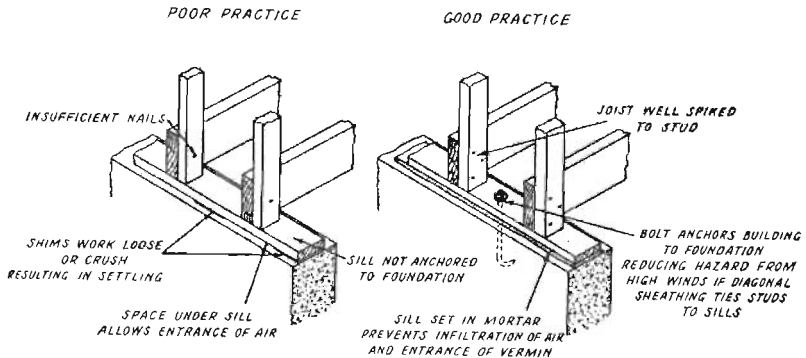

FIGURE 1.—Good and poor practice with foundation sills.

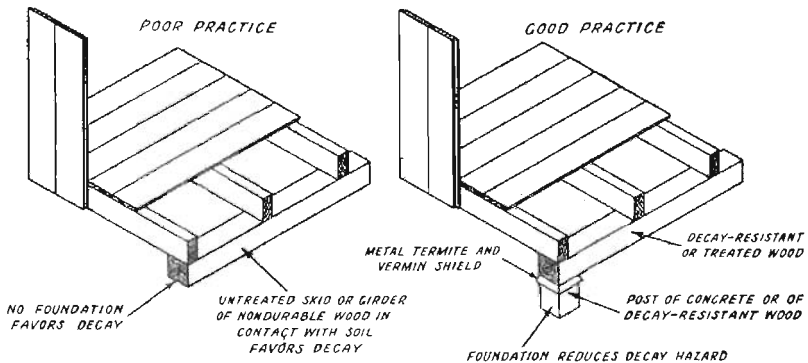
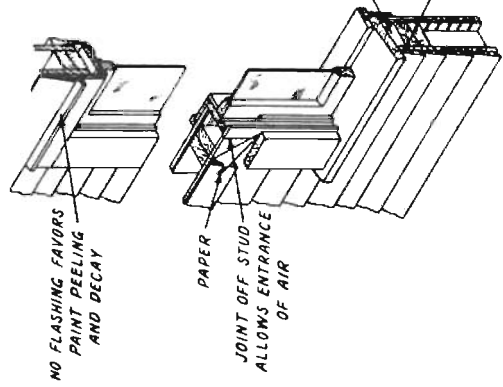

FIGURE 2.—Good and poor practice for foundations of temporary buildings.

POOR PRACTICE



GOOD PRACTICE

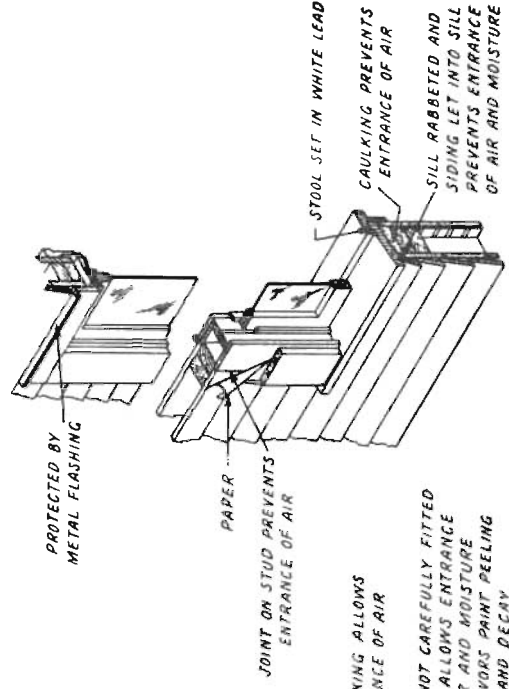

Figure 3.--Good and poor practice with window sash and frames

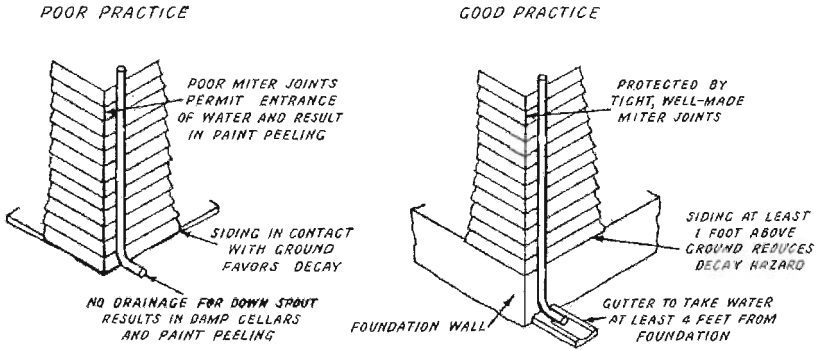

FIGURE 4.—Good and poor practice with siding and down spouts.

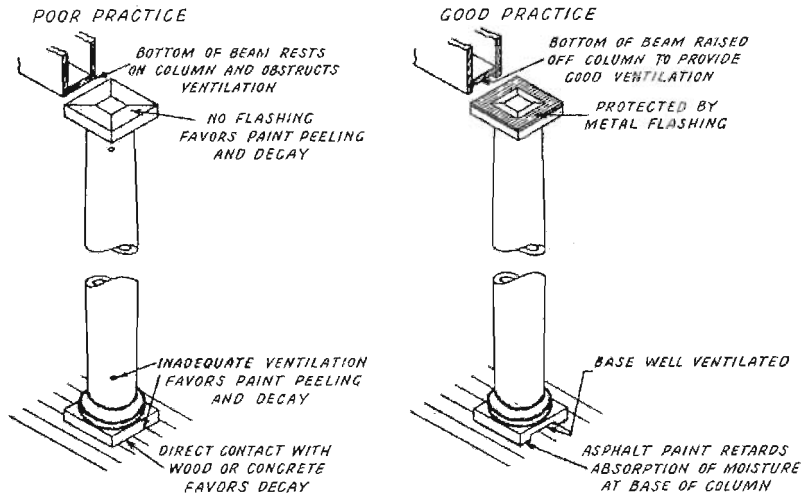

FIGURE 5.—Good and poor practice with porch columns.

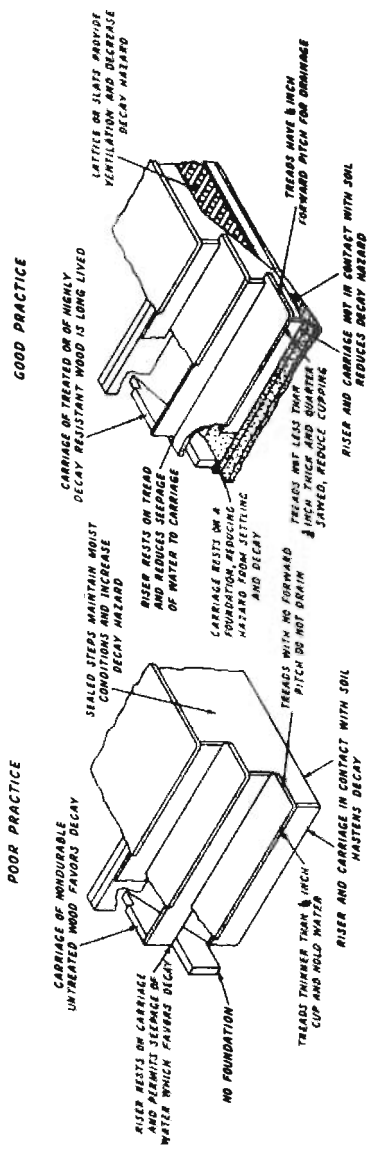

FIGURE 6.—Good and poor practice with porch steps.

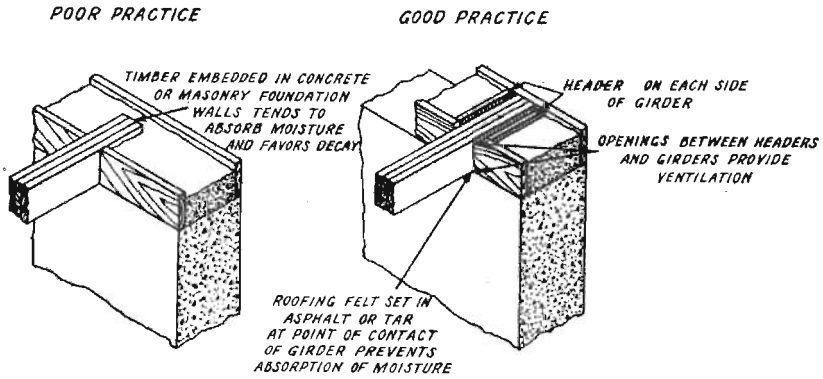

FIGURE 7.— Good and poor practice with girders embedded in concrete or masonry.

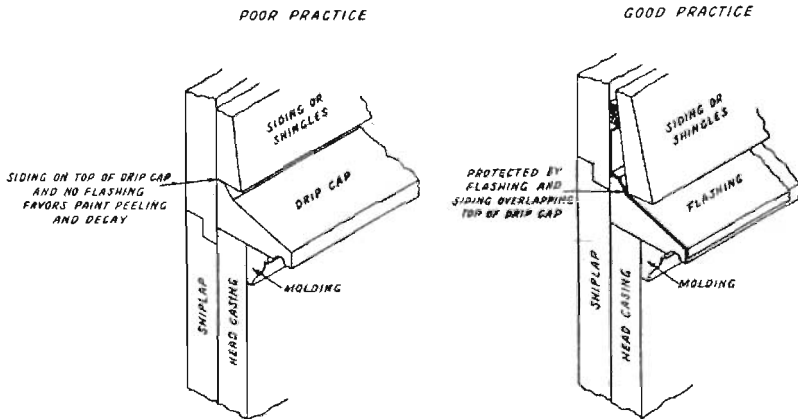

FIGURE 8.— Good and poor practice with drip caps.

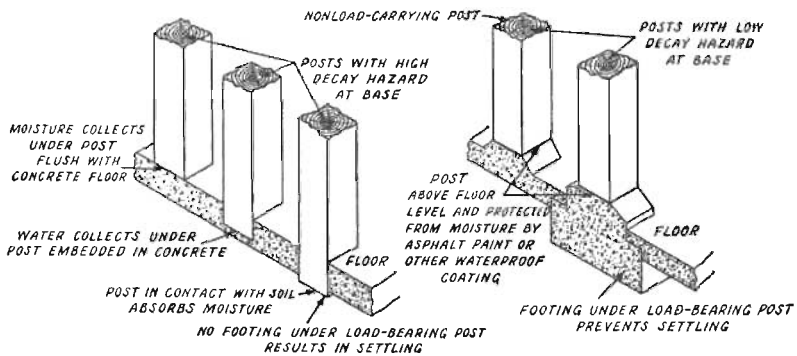

FIGURE 9.—Good and poor practice with posts.

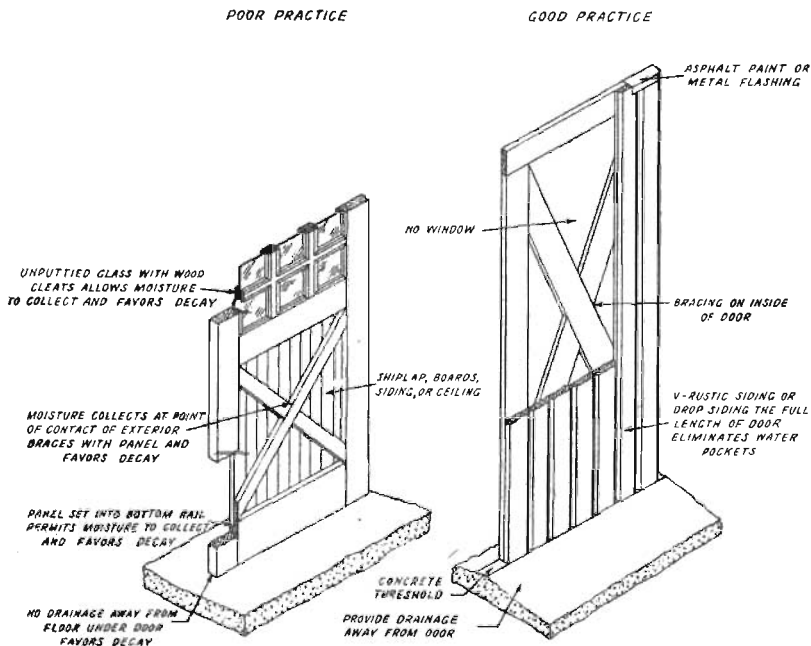
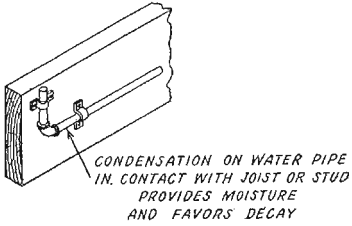

FIGURE 10.—Good and poor practice with garage doors.

POOR PRACTICE



GOOD PRACTICE

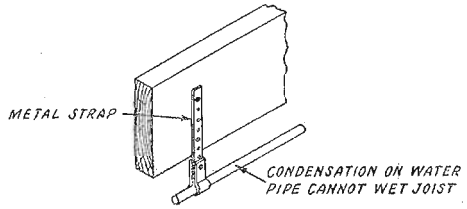
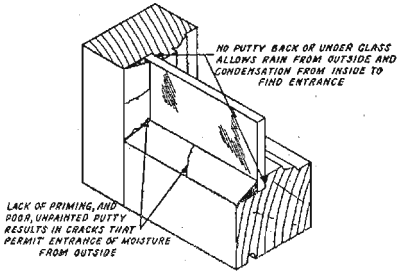

FIGURE 11.—Good and poor practice with water pipes.

POOR PRACTICE



GOOD PRACTICE

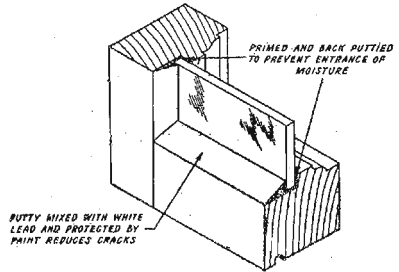

FIGURE 12.—Good and poor practice with window glass.

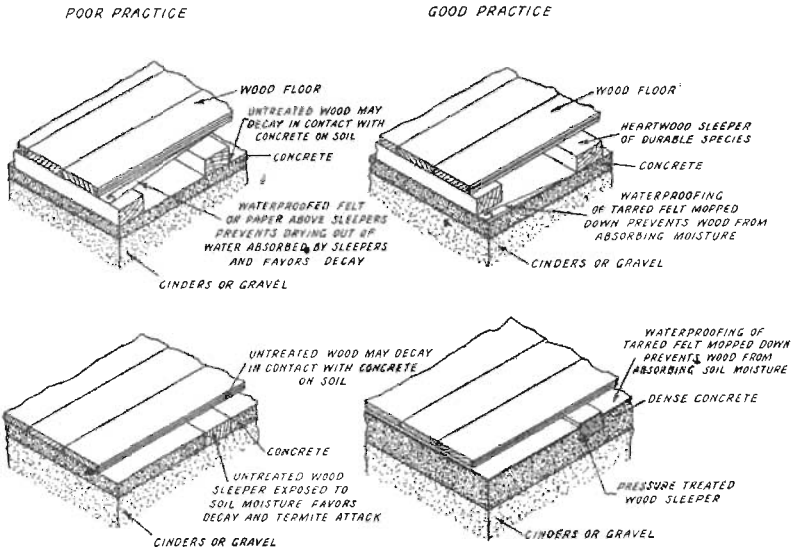

FIGURE 13. —Good and poor practice with timber on concrete or masonry.

For additional illustrations and explanation of the above and other construction details see U. S. Department of Agriculture Miscellaneous Publication No. 358, "Use and Abuse of Wood in House Construction," which can be obtained from the Superintendent of Documents, Washington, D. C., at ten cents per copy.