

U. S. FOREST SERVICE
RESEARCH PAPER
- FPL 29 -
JUNE 1965

U. S. DEPARTMENT OF AGRICULTURE • FOREST SERVICE
FOREST PRODUCTS LABORATORY • MADISON, WIS.

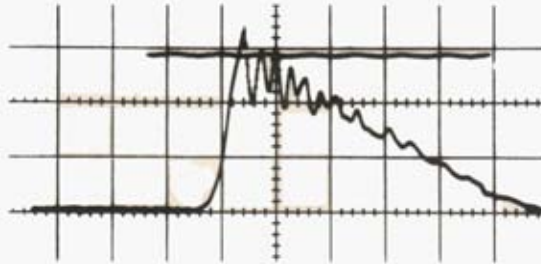

*Performance of Container Fasteners Subjected
to Static and Dynamic Withdrawal*

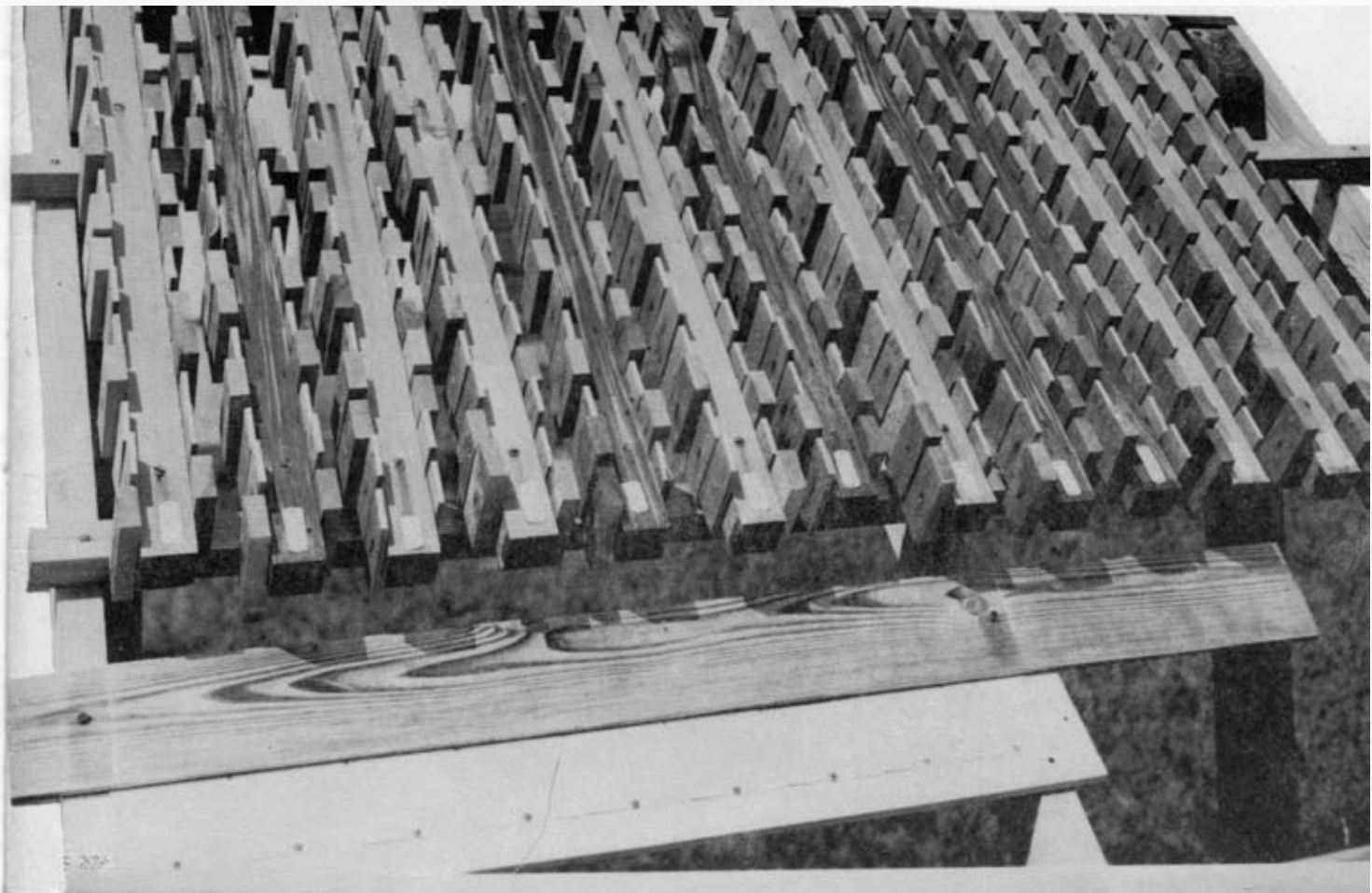

SUMMARY

The performance of 15 different types of metal fasteners was studied in simulated container applications. The specimens were assembled at 20 percent moisture content and subjected to indoor storage under controlled conditions of temperature and relative humidity, and to outdoor storage. Impact and static withdrawal forces were applied after various periods of storage. The instrumentation used to measure maximum loads and time duration of impacts is fully described. Analyses of variance are used to evaluate the data. Helically threaded nails and nylon-coated staples retained their initial resistance to withdrawal after a year of storage at 73° F. and 50 percent relative humidity, while other fasteners exhibited a marked decrease in withdrawal resistance 2 weeks after driving. Helically threaded nails exhibited the best performance after 1 year on an outdoor exposure fence. Some fastener coatings offered resistance to corrosion but did not improve resistance to withdrawal. In general, dynamic withdrawal loads were significantly higher than corresponding static-withdrawal values.



Performance
of
Container
Fasteners
Subjected
to
Static
and
Dynamic
Withdrawal

by

R. S. Kurtenacker, Engineer

FOREST PRODUCTS LABORATORY¹ FOREST SERVICE
U. S. DEPARTMENT OF AGRICULTURE

INTRODUCTION

During the past few years, many new and promising fasteners and fastener coatings have made their appearance. Many of these fasteners are driven by portable pneumatically operated tools and, in general, are designed to be used with wood or products made of wood.

Considerable quantities of wood are used in boxes, crates, pallets, and other packaging applications. In order to ascertain some of the per-

formance characteristics of these new fasteners, the U.S. Forest Products Laboratory undertook an evaluation of fasteners used to assemble two components in a simulated container application. The performance of the fasteners was studied under both static and dynamic withdrawal forces. Withdrawals were made after various periods of storage up to a maximum of 1 year of outdoor storage.

¹Maintained at Madison, Wis., in cooperation with the University of Wisconsin

MATERIALS

The test specimens were of two pieces of wood simulating container applications, such as the fastening of sheathing, side, top, bottom boards, or plywood panel materials to skids, ends, or cleats (fig. 1). The main member of this specimen was of Douglas-fir and measured 36 inches long by 2 inches wide and 2 inches deep. These were cut from a timber that measured approximately 22 feet long by 8 inches wide and 16 inches deep. After dressing the timber to remove surface marks, it was cut into three flitches (A, B, and C) measuring approximately 22 feet long by 16 inches wide by 2 inches thick. These flitches were then ripped and dressed into sticks 2 inches wide by 2 inches thick. The sticks were cut into 36-inch lengths, eliminating wherever possible defects such as knots which might influence the withdrawal performance of the fasteners. The numbering system and method of cutting timber to obtain test specimens is shown in figure 2. To retard change in the initial moisture content of approximately 20 percent, all Douglas-fir specimens were end coated and stored in polyethylene bags at 38° F. and 83 percent relative humidity until ready for use.

The other portion of the two-part specimen consisted of either 1/4-inch-thick, three-ply,

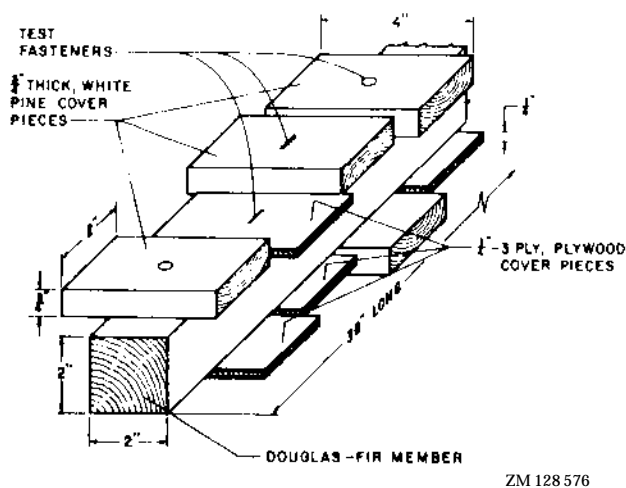

Figure 1.--Arrangement and details of test specimens. Fasteners are located 2-1/4 in. on center, and staggered 1/2 in. Top and bottom locations are offset to avoid interference.

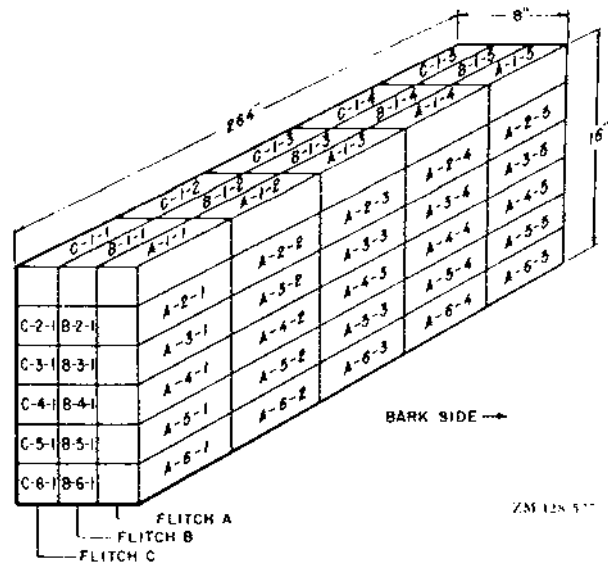

Figure 2.--Numbering system and method of cutting timber to obtain test specimens.

container-grade gum plywood or 3/4-inch-thick white pine. These pieces measured 4 inches in length (parallel to the grain of the face plies of the plywood and parallel to the grain of the white pine) and 2 inches in width.

In general, the 3/4-inch-thick white pine cover piece was used with fasteners 2-1/2 inches long, while the 1/4-inch plywood was used with fasteners 2 inches long so that the penetration of the fastener into the Douglas-fir member was 1-3/4 inches. There was one exception to this, however, because a suitable fastener of the proper length was not available.

The 15 different fasteners evaluated in this study were:

- (1) 0.099--by 2--inch smooth box nail through 1/4--inch plywood.
- (2) 0.112--by 2--inch common bright nail through 1/4--inch plywood.
- (3) 0.131-- by 2-1/2--inch common bright nail through 3/4--inch white pine.
- (4) 14--gage (0.080), 7/16--inch crown, 2--inch leg, plain staple through 1/4--inch plywood.
- (5) 16--gage (0.0625), 7/16--inch crown, 2--inch leg, plain staple through 1/4--inch plywood.

- (6) 16-gage (0.0625), 7/16-inch crown, 2-inch leg, nylon-coated staple through 1/4-inch plywood.
- (7) 0.099- by 2-inch plain T-nail through 1/4-inch plywood.
- (8) 0.099- by 2-inch epoxy-coated T-nail through 1/4-inch plywood.
- (9) 0.097- by 2-inch acid-etched T-nail through 1/4-inch plywood.
- (10) 0.113- by 2-1/2-inch plain T-nail through 3/4-inch white pine.
- (11) 0.113- by 2-1/2-inch epoxy-coated T-nail through 3/4-inch white pine.
- (12) 0.113- by 2-1/2-inch irridite-coated T-nail through 3/4-inch white pine.
- (13) 0.131- by 2-1/2-inch plain T-nail through 3/4-inch white pine.
- (14) 0.100- by 2-1/4-inch helically threaded nail through 3/4-inch white pine.
- (15) 0.131- by 2-1/2-inch common nail with modified head to permit magazine loading in air-operated driver.

METHODS OF INVESTIGATION

Preparation of Specimens

After each piece of Douglas-fir, measuring 36 by 2 by 2 inches, was identified (fig. 2), the bark face and opposite face were marked for fastener location as indicated in figure 1. The pattern used to locate the various fasteners was staggered and spaced so as to avoid interference from nails driven from opposite faces. There were spaces for 15 fasteners on each of the two opposite faces; thus, each face received one of each of the 15 different fasteners. Orientation of the fasteners was accomplished with the use of a table of random numbers.

Behavior of the fasteners was investigated immediately after driving,² and after 2, 6-1/2, 13, 26, and 52 weeks of storage at 73° F. and 50 percent relative humidity; also after 1 year of outdoor storage on an unprotected test fence exposed to the weather.³ The initial moisture content of the Douglas-fir members was approximately 20 percent. This is slightly higher than accepted limits for container material (7)⁴ but not uncommon in actual practice, particularly in pallet construction; thus, drying was expected to occur in those specimens stored in controlled

conditions. Since the specimens stored outdoors were tested upon removal from the site, some drying was expected, but these specimens undoubtedly were subjected to alternate wetting and drying due to climatic conditions. There were 12 replicates for each condition and the selection of the test specimens for each of the storage conditions was accomplished with the use of a table of random numbers.

Specimens were prepared by driving the fastener through a suitable cover piece into the 2- by 2-inch, Douglas-fir member. The smooth box nail and the common bright nails were driven with a hammer as was the helically threaded nail. All other fasteners were driven with suitable pneumatic equipment designated for use with the specific fastener. Efforts were made to drive the fastener flush with the top surface of the cover piece. In assembly of the specimens, staple crowns and T-nail beads were positioned perpendicular to the grain of the face ply in the plywood cover pieces and perpendicular to the grain of the white pine cover pieces.

Static Loading Equipment and Technique

The static loading forces were applied through the use of a conventional universal testing machine operating at a head speed of 0.075 inch per

²Withdrawal was made within 4 hours after driving.

³Specimens were stored at the U.S. Forest Products Lab. exposure site located 8 miles west of Madison, Wis.

⁴Underlined numbers in parentheses refer to Literature Cited at the end of this report.

minute (1). The machine was equipped with an ink pen and recording device for obtaining a graph of the load-deformation for each specimen. Suitable metal blocks and clamps (fig. 3) were used to grasp the cover piece and restrain the main member of the specimen so that the movable head could apply a withdrawal force directly in line with the shank or legs of the fasteners. The maximum load required to start withdrawal or cause failure was obtained directly from the indicator dial of the universal testing machine and checked by the load-deformation chart of the autograph recorder. From this chart it was possible to compute the average energy to maximum load. Because of the limitations of the recording system and the length of time required to conduct each static loading evaluation, load-deformation curves were obtained only to maximum load.

After completion of the test, the condition of each fastener was noted particularly as to corrosion and condition of the coating. A notation was also made regarding the type of failure--whether the fastener withdrew from the piece containing the point or whether the head or crown pulled through the cover piece.

Impact Loading Equipment and Technique

The Forest Products Laboratory toughness testing machine (8) was modified to accommodate the specimens for the impact withdrawal evaluation. In addition to the toughness machine, the instrumentation for noting and recording the phenomenon during impact loading included: a resistance-type strain-gage load cell with special clamps, a calibration box, a cathode ray oscilloscope equipped with a Land process camera, and a triggering device for the scope (fig. 4).

Briefly, the toughness testing machine consists of a metal frame supporting a pendulum. When the pendulum is raised to a predetermined initial position and allowed to fall freely, it applies a load to the specimen by means of a cable or flexible chain fastened around a drum mounted on the axis of the pendulum.

Figure 3.--Method of clamping and supporting test specimen for static withdrawal tests. Thumb screws clamp steel backup plate to cover piece to minimize bending of cover piece during withdrawal. Specimens have been stored outdoors for 1 year.

ZM 126408

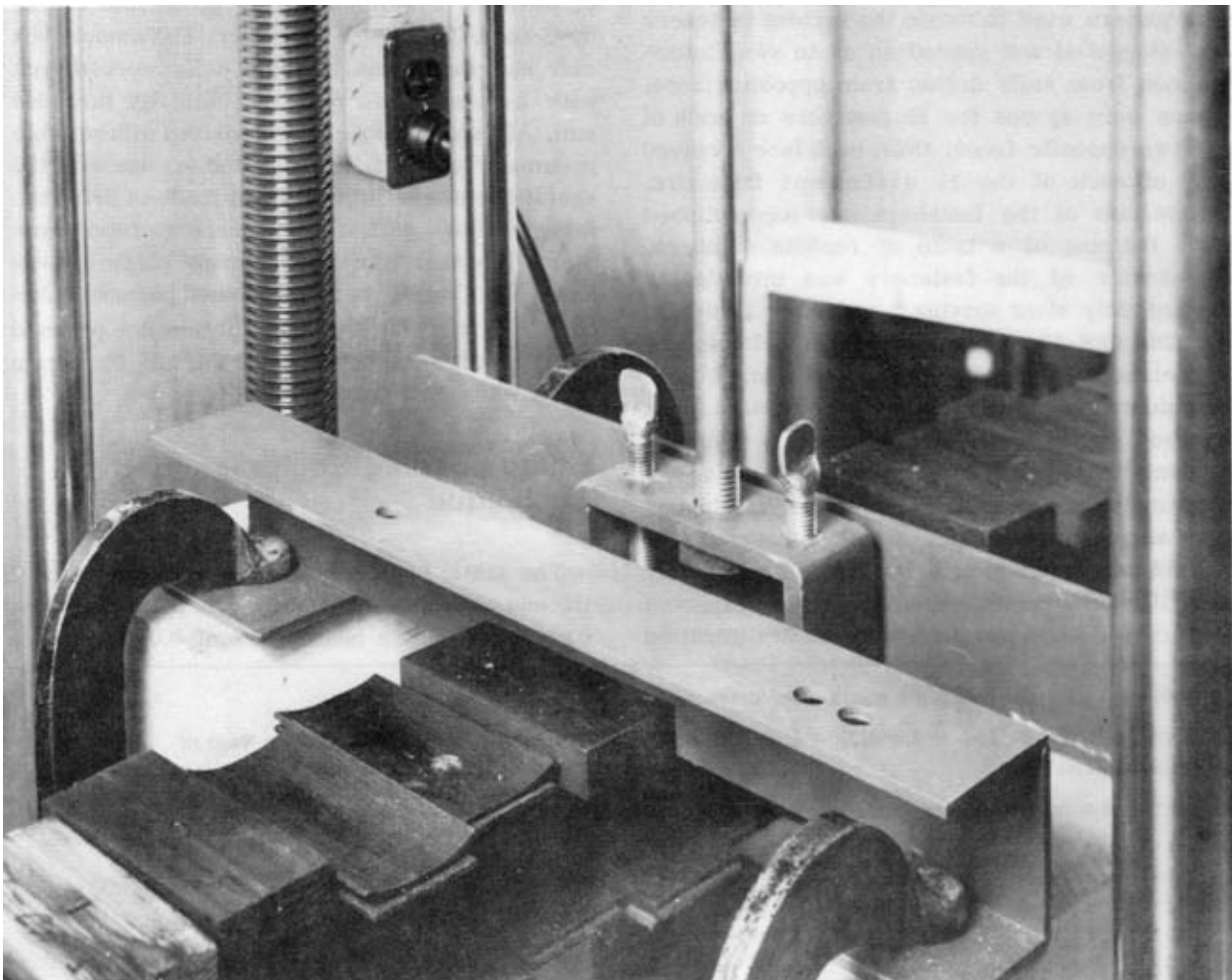

The energy necessary to cause failure of a specimen can be determined by reading the final angle of the pendulum from a fixed graduated scale and vernier. Conversion tables give a value in inch-pounds corresponding to the final angle and this value is an indication of the energy

expended. Estimated average impact-velocity is about 1 foot per second or 720 inches per minute. This agrees with the velocity at impact reported by J. J. Mack (4) in his investigation of dynamic withdrawal of nails using a toughness tester modified somewhat differently.

Figure 4.--Equipment for conducting dynamic withdrawal test of fasteners in simulated container application. (1), FPL toughness machine; (2), resistance type strain-gage load cell; (3), clamp; (4), test specimen restraining supports; (5), calibration box; (6), cathode ray oscilloscope; (7), Land process camera; (8), triggering device; and (9), test specimen.

ZM 126 410

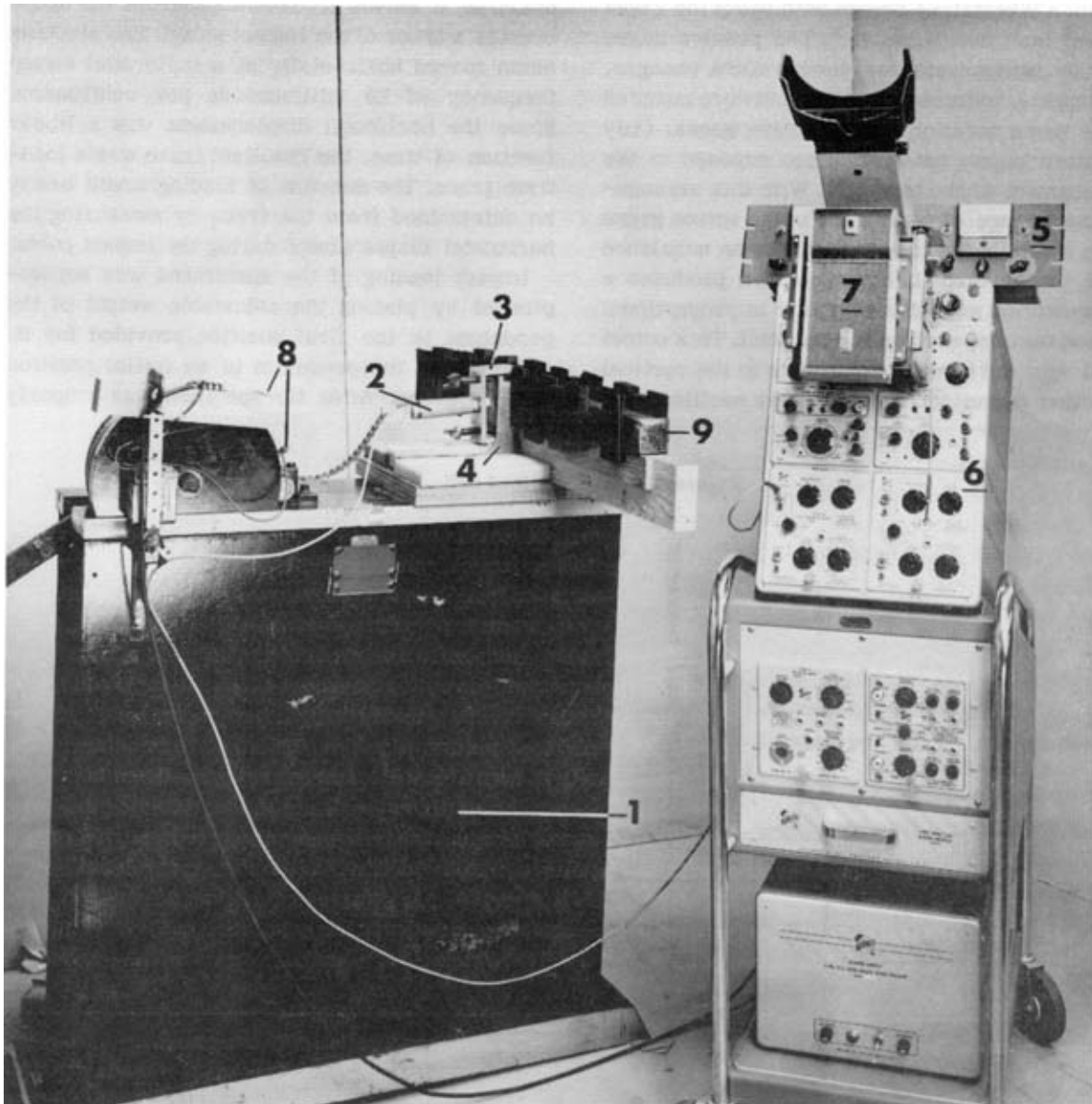

Some slight modifications of the toughness tester were necessary to permit the equipment to be located on the frame and at the same time adequately hold and support the test specimen. The load cell (fig. 5) was connected into the system so that the load supplied by the falling pendulum was applied directly through the load cell. The sensing portion of the load cell consisted of a hollow, thin-walled (0.012 inch thick), steel tube with an inside diameter of 1/2 inch and a length of 2 inches. Bonded to the outside surface of the load cell were four SR-4 resistance-type strain gages; thus, a change in the electrical resistance of the circuit occurs when the load cell is exposed to a tension strain within the elastic limit. The four strain gages were connected to form a Wheatstone bridge with two of the gages "active" and two "passive." The passive gages were to compensate for temperature changes, lead lengths, and other variables and were mounted at the same location as the active gages. Only the latter gages, however, were exposed to the displacement of the load cell. With this arrangement, a change of resistance in the active gages due to strain in the load cell causes an unbalance in the bridge circuit, which in turn produces a direct-current output signal that is proportional to the strain imposed on the load cell. This output signal was fed through amplifiers to the vertical deflection circuit of a cathode ray oscilloscope.

The resulting trace was recorded by means of a Land process camera.

Calibration of the instrumentation was accomplished by using a calibration resistor shunted across a leg of the bridge circuit to produce an unbalance of the bridge equal to that produced by a known load on the load cell. To accomplish this, the load cell was subjected to known tension loading by use of a universal testing machine (6).

To assure proper recording of the trace, it was necessary to trigger the oscilloscope which was set for single sweep operation. The triggering impulse was provided from an external source by the closing of electrical contacts during the swing of the pendulum just prior to impact of the specimen. Thus the deflection of the electron beam as it moves horizontally across the scope creates a trace of the impact pulse. The electron beam moved horizontally at a calibrated sweep frequency of 20 milliseconds per centimeter. Since the horizontal displacement was a linear function of time, the resultant trace was a load-time trace. The duration of loading could easily be determined from the trace by measuring the horizontal displacement during the impact pulse.

Impact loading of the specimens was accomplished by placing the adjustable weight of the pendulum in the first position provided for it, and raising the pendulum to an initial position of 60 degrees. After the specimen was properly

Figure 5.--Sketch of load cell.

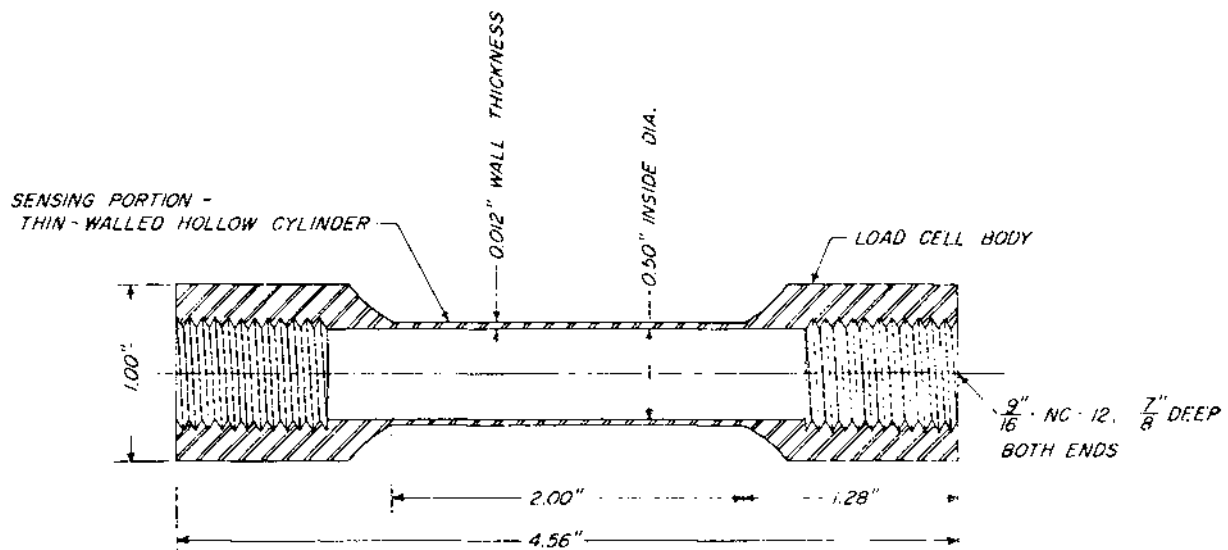

M120158

located and secured in the holding device, and the clamp adequately fastened to the cover piece of the specimen and to the load cell, the pendulum was released and allowed to swing through its arc. This pulled the chain taut and imposed an impact force on the two-component specimen, tending to cause direct withdrawal of the fastener under test. By means of the instrumentation provided, the load-time pulse was recorded and the final angle through which the pendulum swung was read from the scale and vernier of the machine. The sequence of events and the length of chain were arranged so that withdrawal was

completed just before the pendulum completed its downward swing.

The maximum load was calculated from the calibration information and the load-time pulse (fig. 6). The final angle of the pendulum was used with the conversion tables to obtain a value in inch-pounds that was an indication of the energy expended in causing failure.

As was done with static loading, observations and notes were made regarding the type of failure, the condition of the coating on the shank if any, and the degree of corrosion if present.

Figure 6.--Typical traces of dynamic withdrawal of fasteners: A, fastener pulled out (approximate distance 1-3/4 inches); B, fastener pulled through white pine cover piece (approximate distance 3/4 inch); C, fastener pulled through plywood cover piece (approximate distance 1/4 inch). Parallel horizontal traces are calibration lines and represent 370 pounds. Each grid is 1 centimeter and horizontal travel of trace is 20 milliseconds per centimeter. Duration of pulse is influenced by the distance fastener is withdrawn or pulled through.

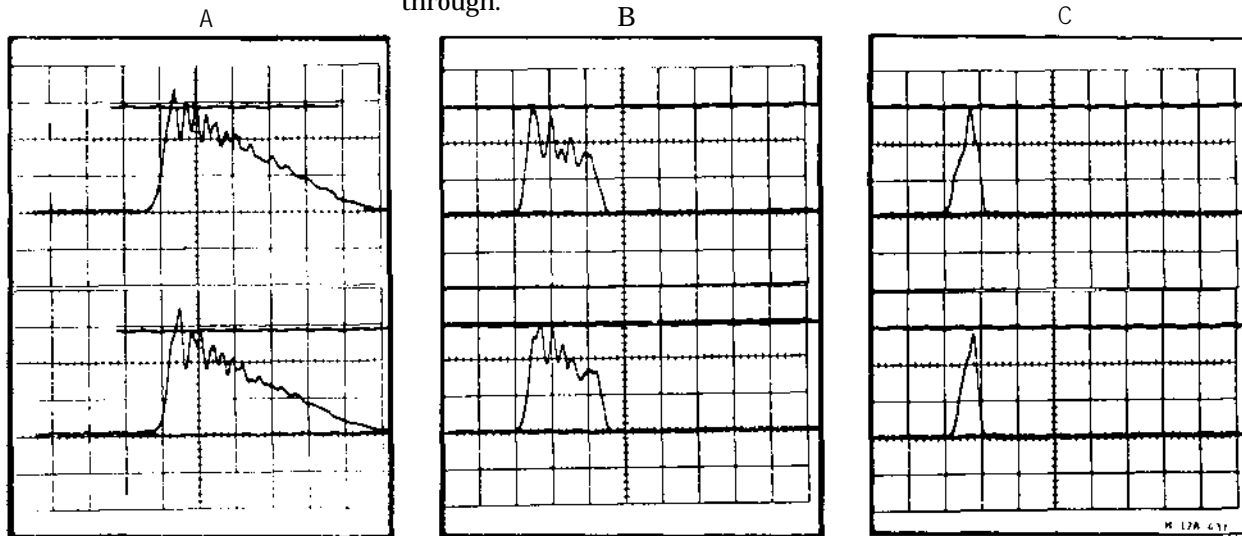

RESULTS AND OBSERVATIONS

Static Loading

A summary of the minimum, maximum, and average withdrawal loads for each fastener after

each of the seven periods of storage is given in table 1. Average values shown are based on 12 replicates for each group. An examination of these results shows that two fasteners (Nos. 6 and 14) exhibited a characteristic quite different from the other 13 fasteners. The nylon-coated staple (No. 6) and the helically threaded nail

Table 1.--Summary of the minimum, maximum, and average static-withdrawal loads of different fasteners after various storage periods

Fastener number	Duration of storage period																				
	None ²			2 Weeks ²			6-1/2 Weeks ²			13 Weeks ²			26 Weeks ²			52 Weeks ²			52 Weeks outdoors		
	Mini-	Maxi-	Aver-	Mini-	Maxi-	Aver-	Mini-	Maxi-	Aver-	Mini-	Maxi-	Aver-	Mini-	Maxi-	Aver-	Mini-	Maxi-	Aver-	Mini-	Maxi-	Aver-
	max	min	age ³	max	min	age ³	max	min	age ³	max	min	age ³	max	min	age ³	max	min	age ³	max	min	age ³
	Lb.	Lb.	Lb.	Lb.	Lb.	Lb.	Lb.	Lb.	Lb.	Lb.	Lb.	Lb.	Lb.	Lb.	Lb.	Lb.	Lb.	Lb.	Lb.	Lb.	Lb.
1	219	294	257	85	138	108	58	108	85	59	111	88	44	125	78	54	163	78	84	157	122
2	200	298	266	66	180	127	41	109	85	61	101	79	52	120	74	53	114	75	92	157	117
3	236	323	276	67	160	116	56	107	82	37	114	78	55	101	80	31	100	70	104	127	212
4	179	310	234	85	152	110	56	94	75	50	90	75	43	97	67	50	83	61	79	135	213
5	204	312	261	61	99	81	53	94	68	47	71	63	40	72	59	50	95	66	89	145	211
6	214	298	246	213	309	245	198	275	241	197	304	252	212	279	243	202	309	258	63	178	113
7	186	310	253	54	196	116	57	168	93	38	99	70	35	106	70	49	95	76	69	127	96
8	185	312	249	75	150	111	69	150	87	64	111	85	53	88	73	54	95	73	64	142	86
9	122	267	211	86	200	156	46	105	79	52	96	78	46	87	66	60	103	78	50	113	78
10	235	316	274	60	232	154	34	142	89	57	134	97	35	101	49	36	173	96	38	251	161
11	214	438	319	135	221	173	67	168	114	55	97	73	58	91	72	69	107	85	76	218	151
12	221	304	261	65	253	112	15	172	106	40	126	72	34	79	51	35	127	72	39	225	123
13	267	358	319	62	184	110	53	113	79	36	110	79	37	89	67	54	103	77	53	222	155
14	272	356	310	256	382	321	288	436	369	303	485	371	232	517	356	252	359	309	193	384	282
15	200	286	238	78	126	96	40	99	63	38	130	64	42	85	56	35	82	62	105	202	158

¹Tested within 4 hours after driving.

²Storage conditions maintained at 73° F. and 50 percent relative humidity.

³Average based on 12 test values.

(No. 14) retained their initial resistance to static withdrawal for at least a year after driving when stored at 73° F. and 50 percent relative humidity. This same phenomenon for helically threaded nails has also been noted by J. J. Mack (5). The remaining fasteners, regardless of type or coating, exhibited the normally expected decrease in withdrawal resistance when evaluated a few days after driving. This decrease was markedly evident as early as 2 weeks after driving and the decrease generally continued rather rapidly for about 6-1/2 weeks. After storage for this period of time, the decrease in resistance to withdrawal generally continued for approximately 6 months but at a considerably slower rate. These fasteners generally exhibited a slight increase in resistance to withdrawal when evaluated after storage for 1 year at 73° F. and 50 percent relative humidity, compared to the withdrawal values after 6 months of similar storage. These results are shown in figure 7, which is a plot of the average withdrawal loads after storage expressed as a percentage of the average initial withdrawal load. For simplicity, this figure shows the performance of all fasteners except Nos. 6 and 14 as a shaded "envelope" type curve. This avoids the confusion of many points

located within a small area and the associated problems of trying to differentiate the various plots of the individual fasteners.

The performance of the fasteners after 1 year of outdoor exposure at the Forest Products Laboratory's exposure site at Madison, Wis., shows that the helically threaded nail retained about 90 percent of its initial static resistance to withdrawal. The nylon-coated staple, which performed similarly to the helically threaded nail under controlled storage conditions, only retained about 46 percent of its initial static-withdrawal resistance after 1 year on the exposure site. After outdoor exposure for 1 year, the remaining 13 fasteners exhibited average withdrawal loads between 35 and 77 percent of their initial static-withdrawal resistance. It is interesting to note that these performances are somewhat higher than the respective performances after storage for 1 year at 73° F. and 50 percent relative humidity. Undoubtedly this can be attributed to the additional drying associated with the lower moisture content of the specimens in the controlled atmosphere and the increased corrosion associated with the specimens on the exposure site.

In container applications, proper nailing exists when no one type of nail failure persists and one

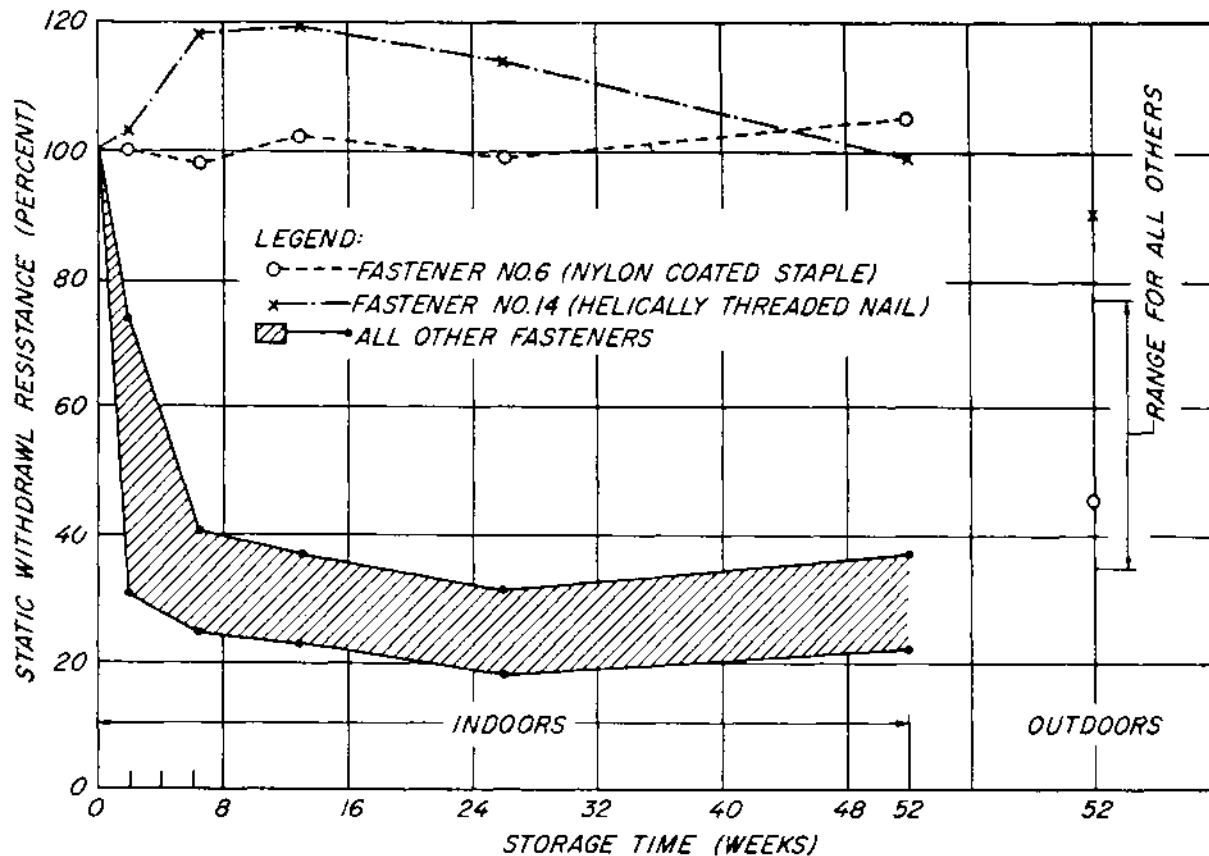

Figure 7.--Effect of storage time on static withdrawal resistance of fasteners. Indoor storage maintained at 73° F. and 50 percent relative humidity. Fastener description: No. 6, 16 gage (0.0625 in.), 7/16-in. crown, 2-in. leg, nylon-coated staple through 1/4-in. plywood; No. 14, 0.100- by 2-1/4-in. helically threaded nail through 3/4-in. white pine.

ZM 128 578

type of fastener failure has as much likelihood of occurring as does another. When evaluated immediately after driving, all 15 fasteners exhibited this characteristic, since some of the fasteners pulled out of the piece holding the point while others either pulled through or started to pull through the cover piece before withdrawing the shank from the member holding the fastener point. This was true for fasteners driven through nominal 1-inch material as well as for fasteners driven through plywood. All subsequent evaluations after storage at 73° F. and 50 percent relative humidity for 2 weeks showed practically no evidence of fasteners pulling through the cover pieces except for fasteners Nos. 6 and 14. These two fasteners retained their resistance to withdrawal to such an extent that they generally

pulled through the cover pieces. Even though fastener No. 6 showed a marked decrease in withdrawal resistance after outdoor storage for 1 year at the exposure site, it still tended to pull through the cover piece.

An examination of the fasteners showed, in general, that those stored outdoors were corroded or rusted to a greater degree than those stored at 73° F. and 50 percent relative humidity for the same length of time; furthermore, outdoor exposure was detrimental to the plywood cover pieces in that they delaminated to a greater degree than those in controlled storage (figs. 8 and 9). The white pine cover pieces stored on the exposure site had signs of discoloration but no evidence of deterioration,

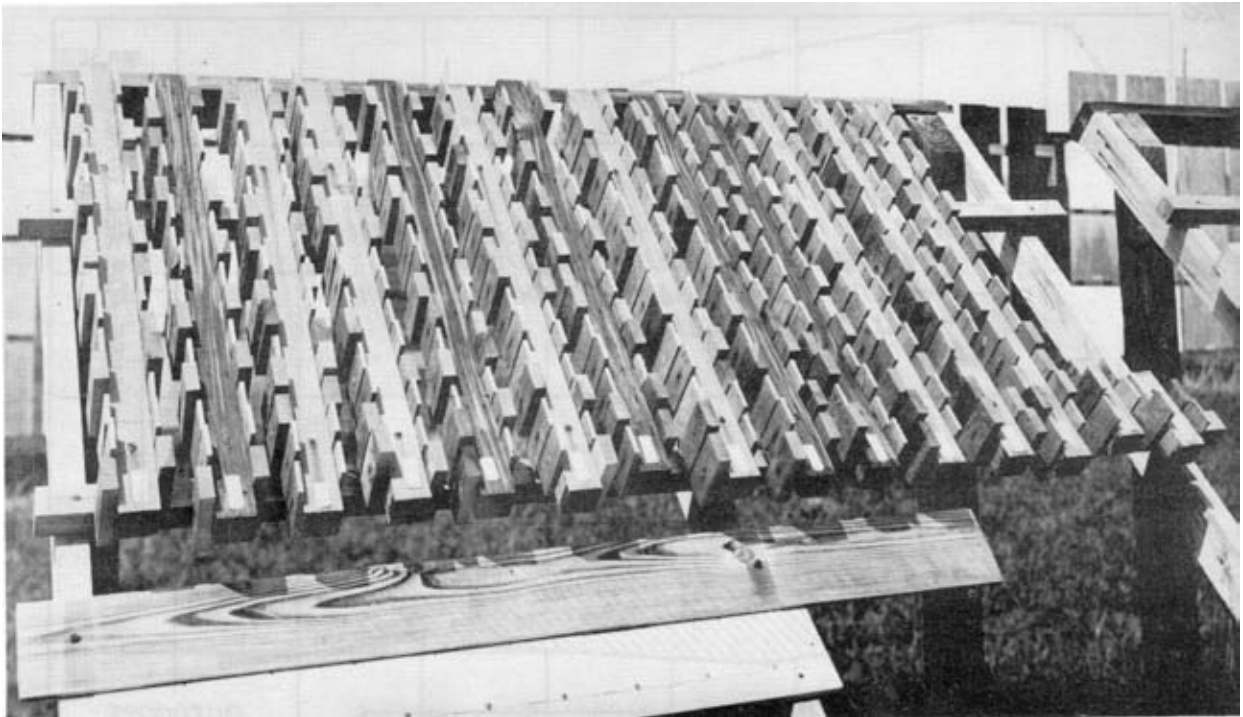

Figure 8.--Test specimens at start of exposure at the U.S. Forest Products Lab. exposure site west of Madison, Wis.

ZM 123 824

Figure 9.--Test specimens after 1-year's exposure at the U.S. Forest Products Lab. exposure site west of Madison, Wis. Note the weathered appearance and the deterioration of the plywood cover pieces.

ZM 123 780



Impact Loading

A summary of the minimum, maximum, and average dynamic-withdrawal load as read from the load-time trace for each fastener after each of the seven periods of storage is given in table 2. Table 3 contains a summary of minimum, maximum, and average energy values for the fasteners as computed from the tables used with the FPL toughness tester after each of the seven storage periods. Average values shown in these tables are based on 12 replicates for each group. As in the static tests, the same two fasteners (Nos. 6 and 14) retained their dynamic resistance to withdrawal for a period of at least 1 year when stored at 73° F. and 50 percent relative humidity. The other 13 fasteners, regardless of type or coating, exhibited a decrease in dynamic-withdrawal loads when subjected to storage before evaluation. This decrease was rather abrupt during the first 2 weeks and continued at a more gradual pace for the balance of the storage. These results are shown in figure 10, which is a plot of the average dynamic-withdrawal loads after storage expressed as a percentage of the average initial withdrawal load.

Outdoor storage for 1 year did not influence the average dynamic-withdrawal load for the helically threaded nail, while that for the nylon-coated staple decreased to about 60 percent of its initial dynamic-withdrawal resistance. The remaining fasteners generally showed a slight increase in dynamic-withdrawal resistance after outdoor exposure over the values obtained after 1 year of storage at 73° F. and 50 percent relative humidity.

Figure 11 shows the average dynamic-energy values expressed as a percentage of the values immediately after driving. Again the performance of the fasteners follows the previously established patterns. Fasteners Nos. 6 and 14 tend to retain or improve their performance with time up to a year of controlled storage. Outdoor storage for a year did not apparently influence the performance of the helically threaded nail while similar exposure resulted in reduced performance of the nylon-coated staple as compared to its performance after storage under controlled conditions. The remaining fasteners exhibited a decrease in dynamic-energy values when stored at 73° F. and 50 percent relative humidity as compared to their performance immediately after driving.

Table 2.--Summary of the minimum, maximum, and average dynamic withdrawal loads of different fasteners after various storage periods

Fastener number	Duration of storage period																				
	None ¹			2 Weeks ²			6-1/2 Weeks ²			13 Weeks ²			26 Weeks ²			52 Weeks ²			52 Weeks outdoors		
	Mini- mum	Maxi- mum	Aver- age ³	Mini- mum	Maxi- mum	Aver- age ³	Mini- mum	Maxi- mum	Aver- age ³	Mini- mum	Maxi- mum	Aver- age ³	Mini- mum	Maxi- mum	Aver- age ³	Mini- mum	Maxi- mum	Aver- age ³	Mini- mum	Maxi- mum	Aver- age ³
1	300	440	360	125	200	160	130	180	155	120	160	140	100	175	130	100	150	120	105	230	165
2	260	370	320	115	170	150	130	200	165	125	175	145	95	175	150	95	150	125	100	265	170
3	370	510	450	145	210	190	145	200	175	125	210	155	110	220	150	100	195	160	155	340	220
4	210	380	305	140	245	170	140	230	165	105	165	150	100	210	150	90	155	125	110	190	150
5	230	370	310	100	195	155	135	185	155	130	200	155	105	160	140	95	160	125	120	225	170
6	260	400	310	210	385	295	120	370	265	250	375	315	185	360	300	265	375	320	125	230	190
7	250	410	350	120	250	165	120	250	180	120	170	135	125	155	140	90	150	135	95	230	145
8	250	370	340	140	215	165	140	210	165	120	175	140	120	190	145	90	215	120	75	150	120
9	250	400	335	120	315	205	105	375	150	100	180	125	90	160	135	70	145	110	85	170	125
10	315	400	370	150	380	255	105	355	195	130	280	185	110	235	150	105	225	155	130	195	160
11	300	420	370	165	370	255	100	280	205	125	190	165	105	190	135	105	170	140	130	220	170
12	300	380	330	150	260	185	140	260	195	120	210	140	100	175	140	100	185	135	140	115	180
13	330	430	390	120	195	165	130	210	160	120	230	150	85	180	125	120	185	145	100	230	175
14	310	430	385	315	400	370	175	520	405	350	500	425	345	475	410	255	485	395	255	475	400
15	330	485	435	165	230	195	130	220	175	120	240	175	120	250	165	105	190	140	130	340	225

¹Tested within 4 hours after driving.

²Storage conditions maintained at 73° F. and 50 percent relative humidity.

³Average based on 12 test values.

Table 3.--Summary of the minimum, maximum, and average dynamic-withdrawal energy of different fasteners after various storage periods.

Fastener number	Duration of storage period																				
	None ¹			2 Weeks ²			6-1/2 Weeks ²			13 Weeks ²			26 Weeks ²			52 Weeks ²			52 Weeks outdoors		
	Mini- mum	Maxi- mum	Aver- age ³	Mini- mum	Maxi- mum	Aver- age ³	Mini- mum	Maxi- mum	Aver- age ³	Mini- mum	Maxi- mum	Aver- age ³	Mini- mum	Maxi- mum	Aver- age ³	Mini- mum	Maxi- mum	Aver- age ³	Mini- mum	Maxi- mum	Aver- age ³
	In.- lb.	In.- lb.	In.- lb.	In.- lb.	In.- lb.	In.- lb.	In.- lb.	In.- lb.	In.- lb.	In.- lb.	In.- lb.	In.- lb.	In.- lb.	In.- lb.	In.- lb.	In.- lb.	In.- lb.	In.- lb.	In.- lb.	In.- lb.	In.- lb.
1	65	235	130	50	95	70	55	90	65	35	90	65	40	75	55	50	75	55	45	90	60
2	55	195	105	30	95	70	50	90	65	50	80	60	20	75	60	25	70	50	40	80	60
3	210	320	260	25	120	75	25	100	70	35	80	60	45	90	70	35	120	70	60	110	80
4	60	145	110	55	90	70	50	80	60	50	80	65	50	100	75	45	85	65	30	80	55
5	45	120	65	15	75	55	50	80	65	50	90	60	40	65	55	50	70	60	35	85	55
6	35	60	50	45	70	60	40	90	60	50	80	65	45	85	60	45	80	55	20	50	35
7	40	90	55	30	65	50	40	65	50	25	60	45	25	55	40	10	60	35	20	60	45
8	25	70	50	30	60	45	30	50	45	30	50	40	30	55	40	20	50	35	15	50	35
9	35	80	50	30	70	50	30	60	50	15	55	45	20	50	40	20	55	40	10	45	30
10	60	165	135	30	150	70	15	75	50	35	90	45	20	50	45	20	50	35	20	60	40
11	130	160	140	40	80	60	40	55	50	30	60	45	25	55	40	20	45	35	25	55	45
12	115	145	135	35	70	55	30	55	45	20	50	40	20	60	40	20	65	40	10	100	45
13	170	270	220	20	100	75	40	80	60	40	85	60	15	75	50	15	70	55	15	75	60
14	40	255	155	190	295	220	155	295	215	75	365	220	125	360	240	145	265	200	90	265	200
15	75	205	150	40	80	55	30	75	55	30	85	55	40	85	55	30	50	35	40	85	60

¹ Tested within 4 hours after driving.

² Storage conditions maintained at 73° F. and 50 percent relative humidity.

³ Average based on 12 test values.

These fasteners were divided into three more or less distinct groups. The first group contained fasteners Nos. 5, 7, 8, and 9 and were characterized by a rather general decline in performance. The second group (fasteners Nos. 1, 2, and 4) exhibited a more marked decline the first 2 weeks of storage followed by a slow and gradual decrease. The average dynamic-energy values of these fasteners (excluding Nos. 6 and 14) generally increased slightly when evaluated after outdoor storage for 1 year as compared to a similar evaluation after storage for 1 year under controlled conditions.

When subjected to dynamic evaluation immediately after driving, every fastener with the possible exception of Nos. 4, 13, and 14 exhibited failures where the head or crown pulled through or started to pull through the cover piece as well as some withdrawal from the piece containing the point of the nail. When dynamic withdrawal was delayed for as little as 2 weeks, the type of failure was predominately withdrawal of the fastener shank, except for the nylon-coated staple and the helically threaded nail. These two fasteners (Nos. 6 and 14) generally had the crown or head pull through or start

to pull through the cover piece. This situation continued even when evaluated after storage for 1 year at 73° F. and 50 percent relative humidity. These two fasteners exhibited this same characteristic failure when evaluated after outdoor storage for 1 year. Occasionally one of the other fasteners pulled through the cover piece when evaluated after a year on the exposure site; however, this was generally confined to fasteners driven through plywood in which deterioration of the plywood promoted this type of failure.

Table 4 shows the results of moisture content determinations and the specific gravity of the test specimens. Specific gravity was determined on the basis of volume at time of test and oven-dry weight.

In any experiment of this type there are possible sources of error. One area that must be considered is that associated with overcoming the inertia of the moving parts in applying the impact forces. Adjustments may be made in the orientation of the toughness tester to compensate for friction, but the load and energy required to overcome inertia of these parts is a definite source of error that should be held to a minimum.

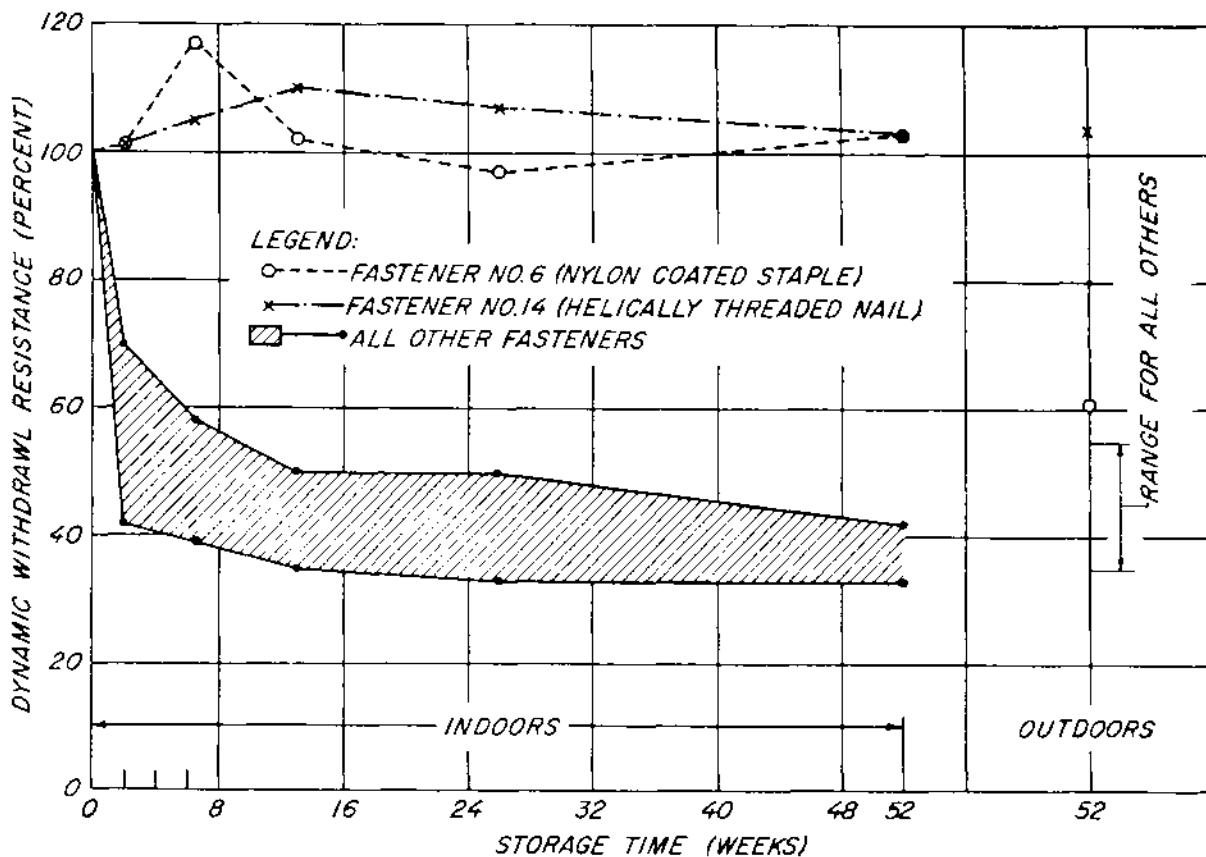

Figure 10.--Effect of storage time on dynamic withdrawal resistance of fasteners. Indoor storage maintained at 73° F. and 50 percent relative humidity. Fastener description: No. 6, 16 gage (0.0625 in.), 7/16-in. crown, 2-in. leg, nylon-coated staple through 1/4-in. plywood; No. 14, 0.100- by 2-1/4-in. helically threaded nail through 3/4-in. white pine.

ZM 128 579

This may be accomplished partially by reducing the size and weight of the parts used to transmit the potential energy of the pendulum (when in the test position) to the specimen. Checks were made at various intervals during the experiment by operating the impact equipment without a test specimen and examining the resultant load-time trace. Since these traces remained essentially the same, the checks indicated that any error thus introduced tended to remain the same throughout the experiment and would influence all impact results by the same constant. It appears reasonable, therefore, to obtain impact-withdrawal values somewhat higher than static-withdrawal values. Since a rapid rate of loading increases the load-carrying characteristics of wood as much as 25 percent (duration of load 1 second) (10), it is reasonable to expect that rapid

loading of fasteners in wood might normally result in higher withdrawal values.

Visual Condition of Fasteners

After each evaluation, the fasteners were examined visually in an effort to ascertain the condition of the coatings, if one was used, and the effectiveness of the coating in preventing corrosion or deterioration of the fastener. The general observations are given in table 5. Conditions were rather conducive to corrosion since the moisture content at time of driving was approximately 20 percent and those specimens stored outside were exposed to the elements of wind, rain, sun, and snow.

In general, the conventional bright nails including the helically threaded nail and the common

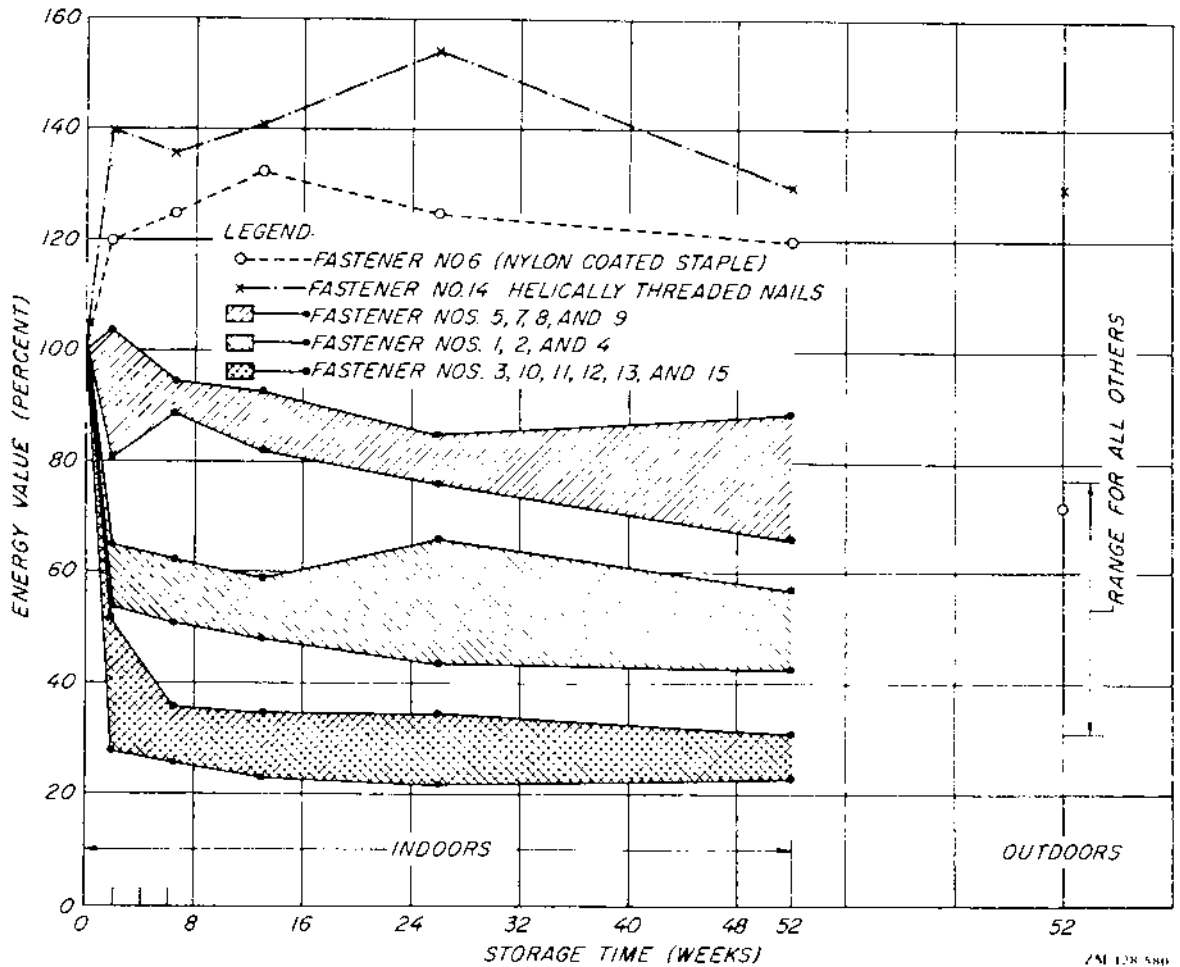

Figure 11.--Effect of storage time on energy values of fasteners subjected to dynamic loading. Indoor storage maintained at 73° F. and 50 percent relative humidity. Fastener descriptions:

- | | |
|---|--|
| No. | (8) 0.099- by 2-in. epoxy-coated T-nail through 1/4-in. plywood. |
| (1) 0.099- by 2-in. smooth box nail through 1/4-in. plywood. | (9) 0.097- by 2-in. acid-etched T-nail through 1/4-in. plywood. |
| (2) 0.112- by 2-in. common bright nail through 1/4-in. plywood. | (10) 0.113- by 2-1/2-in. plain T-nail through 3/4-in. white pine. |
| (3) 0.131- by 2-1/2-in. common bright nail through 3/4-in. white pine. | (11) 0.113- by 2-1/2-in. epoxy-coated T-nail through 3/4-in. white pine, |
| (4) 14-gage (0.080 in.), 7/16-in. crown, 2-in. leg, plain staple through 1/4-in. plywood. | (12) 0.113- by 2-1/2-in. irridite-coated T-nail through 3/4-in. white pine. |
| (6) 16-gage (0.0625 in.), 7/16-in. crown, 2-in. leg, plain staple through 1/4-in. plywood. | (13) 0.131- by 2-1/2-in. plain T-nail through 3/4-in. white pine. |
| (6) 16-gage (0.0625 in.), 7/16-in. crown, 2-in. leg, nylon-coated staple through 1/4-in. plywood. | (14) 0.100- by 2-1/4-in. helically threaded nail through 3/4-in. white pine. |
| (7) 0.099- by 2-in. plain T-nail through 1/4-in. plywood. | (15) 0.131- by 2-1/2-in. common nail with modified head to permit magazine loading in air-operated driver. |

Table 4.--Moisture content and specific gravity of Douglas-fir specimens after various storage periods

Storage period	Moisture content			Specific gravity ¹		
	Mini- mum	Maxi- mum	Aver- age	Mini- mum	Maxi- mum	Aver- age
	Pct.	Pct.	Pct.			
None	18.5	21.9	19.9	0.45	0.53	0.49
2 weeks ²	12.0	14.7	13.3	.45	.55	.51
6-1/2 weeks ²	10.1	11.4	10.9	.48	.54	.51
13 weeks ²	9.0	10.9	10.4	.47	.55	.52
26 weeks ²	8.7	9.8	9.3	.43	.57	.52
52 weeks ²	9.3	10.1	9.7	.46	.58	.52
52 weeks outdoors	14.5	18.3	16.0	.44	.54	.50

¹Specific gravity based on volume at time of test and oven-dry weight.

²Storage conditions maintained at 73° F. and 50 percent relative humidity.

nail with the modified head, when driven into Douglas-fir at about 20 percent moisture content, exhibited signs of corrosion after storage for 2 weeks at controlled conditions of 73° F. and 50 percent relative humidity. These fasteners generally exhibited increasing signs of corrosion as the storage time lengthened, with the worst conditions occurring in those specimens stored outdoors for a year.

The galvanizing employed with the plain staples and some of the plain T-nails was effective to some degree in preventing corrosion of the fasteners. The epoxy-coated fasteners had the coating disturbed or removed, probably during driving, since fasteners coated with epoxy compound generally exhibited more evidence of corrosion than those that were galvanized.

The nylon coating appeared to be reasonably effective in minimizing corrosion, particularly in those specimens stored under controlled condi-

Table 5.--Average visual condition of fasteners after static and dynamic tests were conducted following various storage periods

Fastener number	Description of fastener coating	Duration of storage period							
		None ¹	2 Weeks ²	6-1/2 Weeks ²	13 Weeks ²	26 Weeks ²	52 Weeks ²	52 Weeks outdoors	
1	Smooth box nail	Bright--no evidence of stain or corrosion	Slight rust	Some rust	Some rust	Rust	Rust	Rust--generally entire area	
2	Common bright nail	do	do	do	do	do	do	do	
3	do	do	do	do	do	do	do	do	
4	Plain staple	do	Bright--no evidence of stain or corrosion	Bright--no evidence of stain or corrosion	Bright--no evidence of stain or corrosion	Bright--no evidence of stain or corrosion	Some discoloration	Some discoloration	
5	do	do	do	do	do	do	do	do	
6	Nylon-coated staple	No damage to coating. No evidence of stain or corrosion	No damage to coating. No evidence of stain or corrosion	No damage to coating. No evidence of stain or corrosion	No damage to coating. No evidence of stain or corrosion	No damage to coating. No evidence of stain or corrosion	Some of coating removed. No evidence of stain or rust	Some of coating removed. Some stain and rust	
7	Plain T-nail	Bright--no evidence of stain or corrosion	Slight stain or discoloration	Light stain or discoloration	Light stain or discoloration	Slight stain	Slight stain and occasional spot of rust	Some rust	
8	Epoxy-coated T-nail	No damage to coating. No evidence of stain or corrosion	Most of coating removed. Slight stain or rust	Most of coating removed. Slight stain	Most of coating removed. Slight stain	Most of coating removed. Slight stain	Most of coating removed. Some rust	Most of coating removed. Rust	
9	Acid-etched T-nail	No evidence of stain or corrosion	Occasional stain	Slight stain	Slight stain to occasional rust	Some slight rust	Some discoloration	Some discoloration and occasional rust	
10	Plain T-nail	Bright--no evidence of stain or corrosion	Generally bright. Occasional stain	Generally bright. Some slight stain	Generally bright. Some slight stain	Some slight rust spots	Some rust spots	Rust	
11	Epoxy-coated T-nail	No damage to coating. No evidence of stain or corrosion	Most of coating removed. Some slight stain	Most of coating removed. Slight stain	Most of coating removed. Slight stain	Most of coating removed. Slight stain	Most of coating removed. Some stain	Most of coating removed. Some rust	
12	Iridite-coated T-nail	do	Coating generally appears good. No stain or rust	Coating generally appears good. No stain or rust	Some of gold coating removed. No stain or rust	Large portions of gold coating removed. No stain or rust	Some of gold coating removed. No stain or rust	Some of gold coating removed. Some white discoloration. No stain or rust	
13	Plain T-nail	Bright--no evidence of stain or corrosion	Slight rust	Some rust	Some rust	Some rust	Rust	Rust	
14	Helically threaded nail	do	Generally bright. Occasional rust	Slight rust ³	do ³	do ³	do	do	
15	Common nail with modified head	Damage to red coating used to form nails into strips. No corrosion	Coating damaged. Some occasional stain	Coating removed. Slight rust	Coating removed. Some rust	Coating removed. Some rust	Coating removed. Some rust	Coating removed. Rust	

¹Represents observed condition within 4 hours after driving.

²Storage conditions maintained at 73° F. and 50 percent relative humidity.

³Based on examination of part in cover piece since shank did not withdraw.

tions for a year. There was some evidence of breakdown of the nylon coating in the specimens stored outside for a year. This breakdown was located at the junction of the plywood cover piece and the Douglas-fir member where air-borne moisture could be trapped and possibly become slightly acidic from the extractives of the wood.

STATISTICAL ANALYSIS

From the test results (figs. 7, 10, and 11) it is obvious that two fasteners, the nylon-coated staple (No. 6) and the helically threaded nail (No. 14) performed differently than the others. It is also quite evident from the results (tables 1 and 2) that the same fastener subjected to similar storage conditions sustained different withdrawal loads, depending upon the method of test--static or dynamic. Figures 7, 10, and 11 show that the withdrawal performance of most of the fasteners was influenced by the storage time and conditions. It is, however, rather difficult to interpret any further and more detailed information from the results. For example, is there any significant difference in the performance of fasteners Nos. 1, 7, 8, and 9--and if so, where?

To obtain information regarding performance of the individual fasteners for the seven exposure periods for each test (static and dynamic), an analysis of variance was made for each fastener-test combination--15 fasteners and average static load, average dynamic load, and average dynamic-withdrawal energy. This resulted in 45 analyses of variance. From this, confidence limits at the 95 percent level were calculated⁵ to permit examination of the results for a particular fastener subjected to a specific test at any two of the exposure conditions. These confidence limits are given in table 6 and may be used in conjunction with the average values given in table 1 for static loads; table 2 for dynamic loads; and table 3 for dynamic-withdrawal energy. For example, from table 1 fastener No. 14 had average static-withdrawal loads of 310, 321, 369, 371, 356, and 309 pounds, respectively, when

The irridite coating as applied to the T-nail fastener No. 12 was the most effective in preventing corrosion of the fasteners, even when the test specimens were stored outside for a year. Examination of the fasteners revealed that some of the gold coloring or coating was removed, but there was no evidence of stain or rusting.

tested initially and after storage for 2, 6-1/2, 13, 26, and 52 weeks at 73° F. and 50 percent relative humidity. From table 6, fastener No. 14 has a calculated confidence limit of ± 73 pounds at the 95 percent level; thus, there is no significant difference indicated in the aforementioned withdrawal loads. In a similar manner, the influence of storage time and conditions may be examined for significant differences for any fastener using the average results in tables 1, 2, or 3 and the corresponding confidence limit (table 6) for the fastener-test result combination.

Similarly, to permit examination of the performance of different fasteners at specific conditions and methods of test, an analysis of variance was made for each of the seven storage periods combined with average static loads, average dynamic loads, and average dynamic-withdrawal energy. As before, these analyses were used to compute the confidence limits at the 95 percent level. These limits are given in table 7 and may be used with the respective average test results in tables 1, 2, and 3.

By using these confidence limits, a comparison may be made of fasteners Nos. 3, 13, and 15. These fasteners are the same size and differ only in the shape of the head. Fasteners Nos. 13 and 15 have a residue coating that is used to adhere them in clip form for magazine loading and is not primarily to influence the performance of these fasteners. Such an examination indicates there is no consistent significant difference in the performance of these three fasteners. There is some inconsistency of significance when tested immediately after driving but this disappears

⁵Calculations were based on Section 3-4 of Experimental Statistics Handb. 91 -- "Comparing the averages of several products," by Nancy Gibbons Natralla, pp. 3-40, 3-41, and 3-42. Natl. Bureau of Stds., U.S. Department of Commerce, Washington, D.C. 1963.

Table 6.--Computed confidence limits at 95 percent level for 15 different fasteners based on average test results

Fastener number	Computed confidence limits at 95 percent level for:		
	Average static load	Average dynamic load	Average dynamic withdrawal energy
	<u>Lb.</u>	<u>Lb.</u>	<u>In. -lb.</u>
1	± 27	± 32	± 31
2	± 28	± 35	± 29
3	± 45	± 38	± 26
4	± 26	± 39	± 21
5	± 22	± 30	± 16
6	± 37	± 50	± 11
7	± 37	± 39	± 15
8	± 27	± 34	± 11
9	± 31	± 45	± 13
10	± 53	± 61	± 24
11	± 50	± 43	± 10
12	± 50	± 42	± 17
13	± 41	± 37	± 28
14	± 73	± 64	± 71
15	± 28	± 45	± 29

when tested after 2 weeks of storage.

In a similar manner the performance of fasteners Nos. 1, 7, 8, and 9 may be compared since they are of similar size and differ only in the shape of the head and shank coating or treatment. Such a comparison reveals no consistent significant difference between the performance of these fasteners after various periods of storage. When tested immediately after being driven, fastener No. 1 exhibited a significantly higher withdrawal energy than did Nos. 7, 8, and 9. This is the only instance in which fastener No. 1 outperformed the other three fasteners. No significant difference was noted in the performance of the three T-nails (Nos. 7, 8, and 9).

Similarly a comparison of fasteners Nos. 2, 10, 11, and 12 (similar in shank diameter and depth of penetration, but differing in head con-

Table 7.--Computed confidence limits at 95 percent level for each of the storage periods based on average test results

Storage period	Computed confidence limits at 95 percent level for:		
	Average static load	Average dynamic load	Average dynamic withdrawal energy
	<u>Lb.</u>	<u>Lb.</u>	<u>In. -lb.</u>
None	± 52	± 55	± 48
2 weeks ¹	± 48	± 55	± 29
6-1/2 weeks ¹	± 38	± 51	± 21
13 weeks ¹	± 37	± 38	± 32
26 weeks ¹	± 41	± 40	± 30
52 weeks ¹	± 33	± 40	± 21
52 weeks outdoors	± 62	± 56	± 28

¹Storage conditions maintained at 73° F. and 50 percent relative humidity.

figuration and shank coatings) revealed no consistent significant difference. No one fastener in this group consistently performed better or worse than any other fastener in this group.

With the amount of data obtained in this experiment and the use of the confidence limits, a large number of comparisons is possible. To mention all of them is beyond the scope of this Research Paper; therefore, detailed comparisons are left to the discretion of the individual readers.

Questions often arise regarding a performance comparison of fasteners in wood when subjected to dynamic and static forces. To obtain this comparison, analyses of variance were made between the average withdrawal loads (dynamic and static) for each fastener after each period of storage (15 fasteners x 7 conditions = 105 analyses). Significance was determined by use of the F test at the 95 percent confidence limit (2). This was done by comparing the calculated F ratio to the tabled critical value of F. If the calculated F was as great or greater than the tabled value of F, the effect (average dynamic withdrawal vs. average static withdrawal) was significant. Of the 105 analyses, 99 showed significantly higher values for the average dynamic withdrawal. It is interesting to note

that many of the analyses indicated significantly greater values for average dynamic withdrawal at the 99 percent level. The six analyses that did not show significance were: fasteners Nos. 3, 10, and 13 after 1-year storage at the exposure site; fastener No. 11 immediately after driving; and fastener 14 after 6-1/2 and 26 weeks of storage at 73° F. and 50 percent relative humidity.

This indicates that the average dynamic-withdrawal load for a fastener is generally significantly higher than the average static-withdrawal load for similar conditions. This does not concur with J. J. Mack's findings (4) that in general the maximum load measured from the impact test curves was not significantly different from the static maximum load. Since both investigations used a modified toughness tester and the impact velocities were similar, an explanation of the difference might be found in the

recording systems. It is generally accepted that the pen-type recorder used by Mack does not have the frequency range and accuracy response of a cathode-ray oscilloscope. Indications from the oscilloscope traces in this study are that the frequencies obtained during the dynamic tests were in the range of 60 to 160 cycles per second.

In the study conducted in Australia, the duration of the dynamic test was 1/7 second, or approximately 144 milliseconds. The duration of the dynamic withdrawals reported in this Paper ranged from 20 to approximately 125 milliseconds. Naturally the time is going to be influenced by the depth of penetration and whether or not the fastener pulls through the cover piece or withdraws from the member holding the point (fig. 6). In the Australian study this was not the situation, since the nail was always withdrawn.

CONCLUSIONS AND RECOMMENDATIONS

The following conclusions are based solely on the performance and results obtained in this study and are applicable only when the fasteners are subjected to forces tending to cause axial withdrawal:

(1) Nylon-coated or helically threaded fasteners tend to retain their initial resistance to both static and dynamic withdrawal for at least a year when the wood undergoes a loss in moisture content under uniform storage conditions. Naturally, the performance of nylon-coated fasteners is dependent on the quality of the bond between the nylon and the base fastener. Outdoor storage is more detrimental to the performance of nylon-coated fasteners than to that of helically threaded fasteners.

(2) Smooth shanked, uncoated metal fasteners and those coated with materials other than nylon exhibited a marked decrease in withdrawal resistance whether loaded statically or dynamically 2 weeks after driving.

(3) If fastener assemblies are to be exposed to outdoor storage for a year, consideration should be given to the use of helically threaded nails for improved overall performance.

(4) Nails with modified heads such as T-nails or the clipped head of fastener No. 15 may be

expected to perform as well as similarly sized, conventional bright nails in either static or dynamic withdrawal, providing such heads are oriented for maximum resistance to pulling through the wood fibers. Most fasteners will exhibit a decrease in withdrawal resistance when subjected to storage after driving, particularly if the wood dries during this storage.

(5) Exposure to the elements--sun, wind, rain, snow, etc., causes more severe corrosion of metallic fasteners when driven into wood initially at 20 percent moisture content than if exposed to uniform storage conditions. Plain metallic fasteners driven into Douglas-fir at 20 percent moisture content may exhibit some evidence of corrosion after only 2 weeks of storage in a dry environment.

(6) The irridite coating offers excellent protection to fasteners against corrosion. Galvanizing offers reasonably good protection against corrosion but the epoxy coating offers only little protection. None of these coatings can be relied upon to improve the withdrawal performance of the fasteners.

(7) The nylon coating not only affords good resistance to corrosion but it also improves the withdrawal performance of the fastener. The nylon coating appears to be less effective in

preventing corrosion when the fasteners are exposed to the weather.

Although the conclusions are based on the results of a study involving a single species (Douglas-fir), it is reasonable to assume from past experience with fastener research that these behavior patterns would be similar with other species. Some further work involving representative species of groups 1, 3, and 4 (9) is recommended as a means of checking this assumption.

Some limited previous work (3) indicated that staples and T-nails subjected to dynamic lateral loading did not always sustain higher maximum

loads than when subjected to static lateral loading. In the previous work, some of the fasteners were clinched, which could influence the performance. Further research involving static and dynamic lateral loading of simulated container joints as well as the behavior of clinched fasteners in dynamic withdrawal might be worthy of consideration.

It is also recommended that further analysis be made of the data obtained in this and other related research in an effort to develop some broad performance guidelines for design applications.



LITERATURE CITED

- (1) American Society for Testing and Materials.
1964. Tests for small clear timber specimens (nail withdrawal). ASTM D 143-52.
- (2) Cochran, W. G., and Cox, G. M.
1957. Experimental designs. John Wiley and Sons, New York, pp. 53-58.
- (3) Kurtenacker, R S.
1962. Lateral loading evaluation of staples and T-nails. Mechanical Fasteners for Wood. Building Research Institute, Inc. Pub. No. 1003. Washington, D.C.
- (4) Mack, J. J.
1961. Nail size and withdrawal resistance. Tech. Paper No. 11, Commonwealth and Industrial Research Organization, Australia, Div. of Forest Products.
- (5) _____
1958. Withdrawal resistance of grooved nails. Forest Products Newsletter No. 242, Timber Mechanics Section, Australian Council for Scientific and Industrial Research, Melbourne.
- (6) Nesbit, J. S., Brennen, J. N., and Tarpley, H. I.
1960. High frequency strain gage and accelerometer calibration. Jour. Acoustical Soc. Amer., Vol. 32 (1): 71-75.
- (7) U.S. Department of Defense.
1959. Quality of wood members for containers and pallets. MIL-STD-731.
- (8) U.S. Forest Products Laboratory.
1961. Forest Products Laboratory's toughness testing machine. Forest Products Lab. Rpt. 1308, 28 pp., illus.
- (9) _____
1958. Nailed and lock-corner wood boxes. Forest Products Lab. Rpt. 2129, 50 pp. illus.
- (10) _____
1955. Wood handbook. U.S. Dept. Agr. Handb. 72, 528 pp., illus.