

United States
Department of
Agriculture

Forest Service

Forest
Products
Laboratory

Research
Paper
FPL 355

1979

Simulation of Hardwood Log Sawing

Abstract

Mathematical modeling computer programs for several hardwood sawing systems have been developed and are described. One has judgment capabilities. Several of the subroutines are common to all of the models. These models are the basis for further research which examines the question of best-grade sawing method in terms of lumber value yield.

Preface

This Research Paper is one in a series of three which describe the computer simulation of hardwood log sawing. Mathematically modeled logs with a selection of diameters, core defect diameters, and knot patterns were sawn by four sawing methods, and the resultant values were recorded.

This first paper, USDA Forest Service Research Paper FPL 355, "Simulation of hardwood log sawing," describes the sawing methods, and the background and development of these programs.

The second paper, FPL 356, "Lumber values from computerized simulation of hardwood log sawing," presents the results of the sawing in terms of volume yield and lumber value, and compares them for the four sawing methods.

The third paper, FPL 357, "Programs for computer simulation of hardwood log sawing," lists the programs, model assumptions, and program organization and variables.

Keywords

Computer simulation
Mathematical modeling
Hardwood sawing
Computer programs
Quadrant sawing
Cant sawing
Live sawing
Decision sawing
Grade sawing
Grade yield

Simulation of Hardwood Log Sawing

By
D. B. RICHARDS¹
W. K. ADKINS¹
H. HALLOCK, Forest Products Technologist
and
E. H. BULGRIN, Supervisory Forest Products Technologist

Introduction

The profitability of a hardwood sawmill operation depends upon many variables: log quality and size, log placement on the carriage, type of sawing method used, hidden defects within the log, yield of each grade of lumber and the current value of each grade, edging, trimming, and decisions regarding ripping and cross cutting to raise the grade, as well as all the cost and production factors involved in mill operations. The very large number of variables affecting the sawn-log value and the increased production rates due to current mechanization trends, result in a situation in which it is virtually impossible for the operators to make the correct timely decisions necessary to achieve the highest practical lumber values from their mills.

The automation of these decision making processes and/or the development of "rules of thumb" have been under investigation for some time. A completed step in this investigation is the grading program for hardwood lumber developed by the Forest Products Laboratory (FPL)^{3,4} which, given a mathematical description of a board with its defects, returns an accurate National

Hardwood Lumber Association (NHLA)⁵ board grade.

The programs outlined in this paper were developed at the University of Kentucky using an IBM 370/165 for investigation, within five sawing methods, of some of the three-dimensional factors affecting final sawn-log value: initial placement of the log on the carriage, hidden defects and defect clusters, edging method, rerip location, kerf size, and both centered and off-center core defects.

Sawing Methods

Simulation models were developed for quadrant sawing, cant sawing, decision sawing, live sawing, and live sawing plus reripping for grade. Quadrant and cant are symmetrical, 4-sided sawing methods. Decision sawing is a 4-sided sawing method, using a decision making process, which, for each board cut from the log, tries to pick the log face which promises the best resulting board. Decision sawing may yield unsymmetrical boards and will respond to uncovered hidden defects, whereas the other methods do not. Live rip is a variation of live sawing. In each sawing method the boards are all of the same thickness and are

referenced and spaced with respect to a saw kerf along the log axis (pith).

Quadrant Sawing

The center section for the quadrant method was arbitrarily picked to be a square cant that will yield four boards. Progressing outward from this center square cant the boards increase in width in each quadrant in a stepwise fashion until the bark (i.e., log surface) is reached and then decrease appropriately to fit in the slab. In the computer program each quadrant is cut completely before progressing to another but the board widths and the way they fit together at the corners are the same as would

¹ Professor of Forestry, Dept. of Forestry, and former graduate student, Dept. of Computer Science, University of Kentucky, Lexington, Ky.

² Maintained at Madison, Wis., in cooperation with the University of Wisconsin.

³ Galiger, Lynn and Hiram Hallock. 1971. A program to grade hardwood lumber. Unnumbered Supplement to USDA For. Serv. Res. Pap. FPL 157. For. Prod. Lab., Madison, Wis.

⁴ Hallock, Hiram and Lynn Galiger. 1971. Grading hardwood lumber by computer. USDA For. Serv. Res. Pap. FPL 157. For. Prod. Lab., Madison, Wis.

⁵ National Hardboard Lumber Association. 1978. Rules for the measurement and the inspection of hardwood and cypress lumber. NHLA, Chicago, Ill.

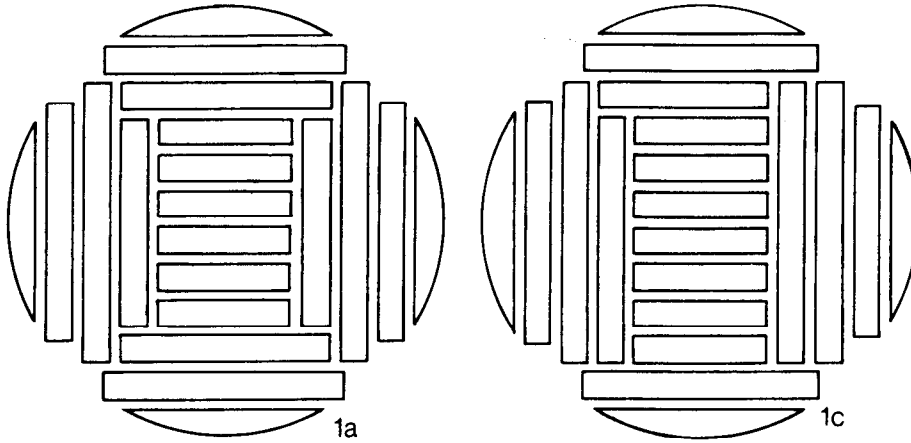

(M 148 324)

(M 148 325)

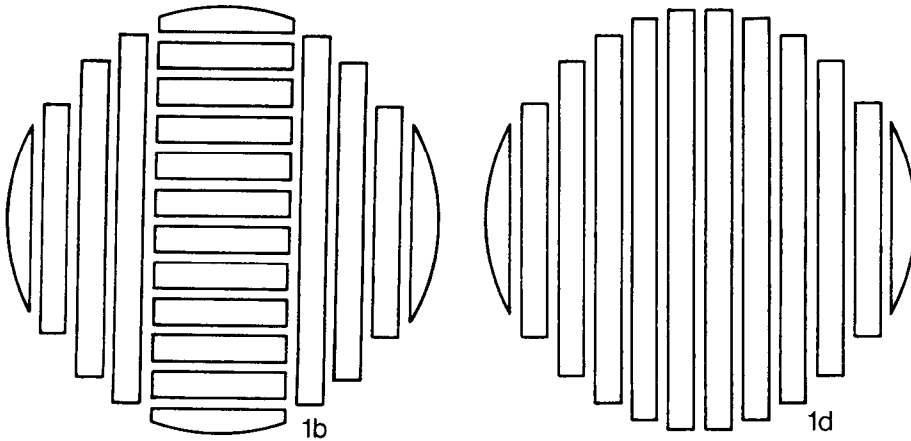

(M 148 326)

(M 148 327)

Figure 1. End views of logs sawn by: A. quadrant method, B. cant method, C. decision sawing (this is only one example: this method is variable due to the many possible decisions), and D. live method. Live sawing with rip is not shown because it is only a variant of live sawing that rips those wide central boards that have core defect on the outer face.

result if the log were turned about its axis after each board was cut, 180° turns alternating with 90° turns until the center square cant remains and is sawn into four boards (fig. 1A).

Cant Sawing

By cutting slabs and boards from faces 1 and 3 in the cant method, a central cant is produced that has a selected thickness. This central cant is then turned 90° and sawn into boards (fig. 1B). While in current studies the central cant was arbitrarily given a thickness of 2 inches less than half the log diameter $[(D/2)-2]$ it can, of course, be assigned any reasonable thickness.

Decision Sawing

The decision sawing method simulates the decisions of a human sawyer in grade sawing. Faces 1, 2, 3, and 4 of the log are sawn in sequence until the log is square and wane-free at midlength. Each exposed face of the log is then graded by the FPL computerized grading program,^{3,4,6} the highest grade face is selected for sawing (surface area is used to decide ties), and the selected face is sawed until a grade drop occurs. The program again grades every affected face and selects the highest grade face for sawing (surface area decides ties) and continues sawing until a grade drop occurs. Log turning and sawing continues in like manner until a

central square cant remains that will yield exactly four equal boards when parallel sawed. As noted earlier, some of the boards resulting from decision sawing may be unsymmetrical with respect to the log axis (fig. 1C).

Live Sawing

A saw kerf bisects the log along the central axis in live sawing and the plane of each subsequent saw cut (and hence each board face) is parallel to this central cut (fig. 1D)

Live Sawing with Ripping for Grade

In ripping, the log is sawed as in live sawing but the outer face of each board is then evaluated for defect type. If the central cylindrical core defect shows up on the outer face of the board, this defect is automatically ripped out and the boards produced are regraded and revalued. If the sum of the values of the boards so produced is higher than the value of the original wide board, the new rip sum is substituted for the original wide board value. If the rip sum is less than the original wide board value, then the original wide board value is retained and it is assumed that the board would not have been ripped. The rip subroutine is applied in sequence to each board that has the central core defect appearing on the outer board face.

Program Constants

In all these methods any less-than-log-length, side-cut boards are trimmed back by decrements of 1 foot until the small end of the board is at least 2½ inches wide. Any board with excessive wane (bark or lack of wood) is edged by parallel saw cuts to reduce the length of wane to half or slightly less than half the board length. Each board produced was graded by the FPL computer grading program and given a value based on Appalachian red oak (*Quercus* sp.) prices. Of course any other price schedule for any wood graded by standard grades could have been used.

In each program, the log is cut 12 separate times at 15° increments of

⁶ Richards, D. B. 1973. Hardwood lumber yield by various simulated sawing methods. *Forest Prod. J.* 27(12):47-50

⁷ Lemske, Abe. 1978. Hardwood market report May 20, 1978. 4 p. Abe Lemske, Memphis, Tenn.

rotation on the carriage (fig. 2) to investigate the effect of initial log placement through 180°. The saw initially cuts the zero-degree face of the log. All boards are cut parallel to the central log axis (pith).

Boards are cut from the log one at a time, defects inserted, and the boards graded by the FPL grading program. Twenty-two defects per board are the maximum currently allowed by this program. Grades returned are Firsts and Seconds (FAS), FAS One Face (1F), Selects, One Common (1C), Two Common (2C), lumped 3A/3B, and "not lumber." The simulation programs arbitrarily assign a grade of 3A/3B if the number of defects exceeds 22.

A wane defect occurs on an edge when the board halfwidth is less at any point than at the board midlength. The board face is described in Cartesian coordinates with (0.0) at the lower left corner of the board. All defects are measured in ¼-inch increments and are placed on the board face as rectangles with dimensions of the maximum length and width of the defect (fig. 3).

Log Model

Logs are simulated as truncated cones and can be assigned any reasonable amount of taper. A central core defect is assumed to be of such low quality that it yields no allowable clear cuttings.⁵ This cylindrical core defect can be assigned any reasonable diameter and, in addition to being located centrally can be displaced to any rational off-center location. Each knot is simulated as a solid conic section of a sphere (i.e., a cone capped with the spherical surface). The tip of the cone is at the log axis and the knot is terminated by a spherical surface with the knot length as radius. The knot length can be designated to terminate in the log or outside the log. Any number of knots can be placed in the log and each knot can be assigned any longitudinal or periclinal position in the log.

Program Description

The programs described were written in FORTRAN G for the IBM 370/165 at the University of Kentucky. Initialization, program control, and printing of results are performed by the main program. Cutting of a board

and edging are performed by subroutine KERF. Wane defects are inserted by subroutine WANE. Knots are inserted by subroutine KNOT. The core defect is inserted by subroutine CORE. Linkage to the FPL grading program is performed by subroutine GRADE. Board value is determined by subroutine PRICE. Best face determination in decision sawing is performed by subroutine DECIDE. Reripping for grade is performed by subroutines RERIP, which prepares and updates rerip parameters, and RIP, which performs the rip and prepares the grading linkages for the grading of each rip section. All programs are similar within sawing method idiosyncracies.

The typical program is described, with differences due to sawing methods noted.

Main Program

Processing begins with initialization of program parameters. User-supplied parameters are read: log diameter (small end), length, and taper: number of knots and their height in the log, periclinal angle, length, and a value for knot taper (24° taper yields a 3.4-inch-diameter surface knot in a 16-inch-diameter log, for example): cylindrical core defect diameter and its linear and angular offset from log center, sawing parameters such as kerf width, board thickness, and rerip kerf width (in reripping only): price per boardfoot of each of the five lumber grades. Other parameters used by the program are calculated: total available boardfeet in the log: the location of the initial cut on each face to be sawn (depending on the sawing method). Parameters used to evaluate sawing performance are initialized.

For each of the twelve 15° rotations of the log on the carriage the log is sawn, defects inserted, and the values and yields calculated. The log is sawn one board at a time in the order defined by the sawing method; all wane, knot, and core defects are located on the outer face and the board face is then graded. The process is repeated for the inner board face and a final board grade and value is determined. The board is then reripped, if applicable. After the log has been squared at mid-length in decision sawing, each affected log face is regraded if a grade drop has

occurred at the currently cut face, and the next board is cut from the best log face.

The results of each rotation on the log carriage are printed. rotation value, surface measures⁵ realized in each grade, total surface measure yield, percent of available surface measure realized, percent of surface measure realized in each grade, total dollar value yield, order of faces cut and their board grades (in decision sawing), and rerip surface measures in each grade, total rerip surface measure, and rerip surface measure loss (all in live rip).

The high, low, and average values for the 12 carriage positions are printed.

KERF

Subroutine KERF cuts a board from the current log face. If the resulting board is not lumber (less than 4 ft long, 3 in. wide at the midpoint, and 2.5 in. wide at the narrow end) another board is cut. If the face has been completely cut (i.e., all boards between the central cant and the bark have been cut) and no more boards are available, control is returned to the appropriate place in the main program for the decision as to the next face in the cutting order.

Once the board has been cut from the face, the total width of wane is limited to 4 inches to avoid overloading the grading program with an excessive number of defects. If the total wane exceeds 4 inches or the board is less than 2.5 inches wide at the small end, or less than 3 inches wide at midlength, the board is cut back in 1 foot decrements until either the wane and width units are met or the board becomes shorter than 4 feet. Another board is cut from this face if the current board becomes too short (except as described for the decision sawing method).

The board width (at midlength) and length are converted to ¼-inch units. Defining the board width as the width at midlength results in a board which is rectangular and wane-free for at least the first half of its length. This constitutes the "edging" method used. The unrounded surface measure is calculated and the length and width stored in locations in the defect location array. The grading program requires that they be stored in these locations for correct results

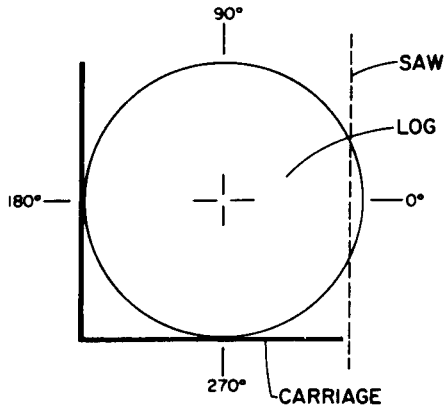

Figure 2. End view of a log on the sawmill carriage. The knots are positioned with respect to the zero point in a clockwise manner, but, to rotate the plane of the initial saw cut in a clockwise direction around the log for the various rotational positions, the log itself is rotated counter-clockwise as indicated by the angular increase.

(M 148 328)

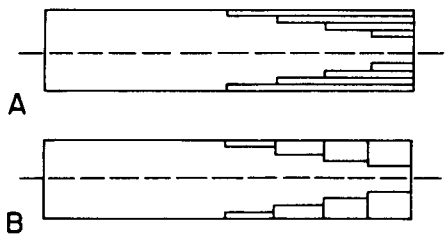

Figure 4. Diagrams of the two possible ways of simulating wane defects as rectangles. While either is possible, only B. will work properly in the FPL program.

(M 148 306)

WANE

Subroutine WANE locates the coordinates of all wane defects on the current face of the current board. Since the board has been "edged" by subroutine KERF so that it is wane-free for at least half its length, a new wane defect will be generated each time the board halfwidth decreases by up to ¼-inch from the halfwidth at the midpoint (all defects are in ¼-in. units). The method of recording the wane defects is critical to the correct operation of the grading program. Figure 4A is incorrect for use by the grading program; figure 4B shows the required method.

Boards resulting from live, cant, and quadrant are symmetrical about

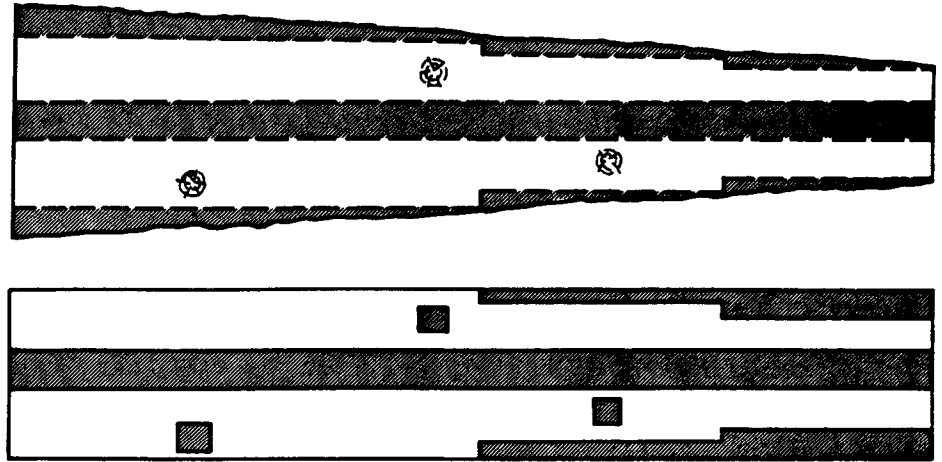

Figure 3. Diagram of a board with wane, knot, and core defects, and a diagram of how the computer inserts these into the board for grading purposes.

(M 148 322)

the board centerline, so the wane defects are also symmetrical. In decision sawing the wane is determined separately for each edge of the board. The defect code is set to indicate a wane defect to the grading program. The coordinates of the wane defects found are converted to ¼-inch units and stored in the defect arrays.

KNOT

Subroutine KNOT determines the location of knot defects on the current board face. The knot is simulated as a cone with the tip at the log axis (pith) and the large end terminated by the spherical surface generated by the knot length as radius. This knot can be assigned any positive length so it can extend to the log surface or beyond, or it can terminate within the log at any depth as a buried or hidden knot. Because it can be buried at any depth and positioned at an arbitrary angle with respect to the board face, its intersection with the board face (if an intersection occurs) can describe a variety of defect configurations.

A knot may entirely miss the board face under any of the following conditions: the knot length is insufficient to reach the board face; the angle of the knot with respect to the board face is such that they cannot intersect; or the knot lies above the top of the board due to log taper or board cutback. The knot will, in these cases, place no defect on the board and control is returned to the calling routine.

If any intersection occurs, the defect coordinates along the board width are first determined. A board-width-dependent sector system is used to simplify the determination of these coordinates (fig. 5). The sectors are really "pseudo-quadrants" because they do not even approximate 90°, but for brevity of nomenclature they are called quadrants in the program comments. Zero degrees is defined as on the line from log center perpendicular to the board face. Note that boards resulting from the decision sawing method may not necessarily be symmetrical about this zero-degree line (fig. 1C). Any knots that lie entirely within sector II and/or III will completely miss the board face and result in no defect by definition of the coordinate system (fig. 6A), leaving those knots lying wholly or partially within sectors I and/or IV (figs. 6B, C, D) as the only ones that intersect the board face. When the coordinates along the width have been calculated, the actual proportion of the possible halfwidth within the board (actual halfwidth/possible halfwidth) is also calculated (fig. 7).

The knot defect coordinates along the board length are next calculated. The actual length of the knot in the board is estimated as the product of its possible length multiplied by that proportion of half-width found above, up to a maximum of the possible length (fig. 7). The value is exact for those knots that completely intersect the board face.

The resulting defect coordinates

are converted to 1/4-inch increments, truncated at the board edges, and stored in the defect location arrays. The defect code is set to indicate a knot defect to the grading program. Control is then returned to the calling routine.

CORE

Subroutine CORE locates the coordinates of the intersection of the solid cylindrical core and the board face. As the core is assumed to be untapered and to extend the full length of the log, the defect will extend the full length of the board and be of constant width for the full board length.

The user-supplied linear and angular core offset from log center are used to determine the center of the core defect with respect to the board. The angle of core offset is adjusted according to the current angular position of the log on the carriage to place the core center at the correct position with respect to the saw face. The width-coordinates are defined by the intersection of the board face and core defect (fig. 8). The length-coordinates are zero and the value that is the board length, since the defect extends the full log length.

The adjustment of the core angular offset is performed in the main program for cant, quadrant, and live sawing; the adjustment is performed in subroutine CORE for decision sawing.

The defect locations are converted to 1/4-inch units, truncated at the board edges, and stored in the defect arrays. The defect code is set to indicate a core defect to the grading program.

GRADE

Subroutine GRADE performs the linkage to the FPL grading program. The version used on past work allowed only 22 defects. GRADE checks the number of defects and, if more than 22 (or 44 in the future), arbitrarily assigns a grade of 3A/3B and prints a message noting that the defect limit was exceeded. Parameters passed to the grading program are the number of defects, the defect type code array, and the defect location arrays. The FPL grading program returns a grade and a rounded surface measure. GRADE returns the current board face grade.

PRICE

Subroutine PRICE determines the board grade, based on the grade of each side according to the matrix in table 1, and calculates the resulting board value based on its surface measure and the price for that grade. Parameters passed to PRICE include a variable which keeps running track of the total realized log dollar value and an array which keeps track of the surface measure realized in each grade. (In live rip, a board section resulting from a rip for grade may be the "board" being priced, so the appropriate rerip variables are passed.) These variables are updated with the new board value and surface measure in the appropriate grade. Control is then returned to the calling routine.

DECIDE

Subroutine DECIDE is particular to decision sawing. It picks the face of the log for cutting that should yield the best board. The main program

has already caused all of the affected log faces to be regraded after a grade drop occurs on the current face so that all log faces, their grades and surface measures are known to DECIDE, as well as the grade of the

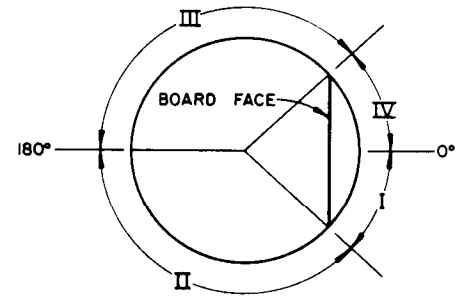

Figure 5. The sector system used for referencing a knot position to a board face. Despite the fact that they are not true quadrants, for convenience they are referred to as quadrant I, quadrant II, ect., in the program subroutine KNOT.

(M 148 307)

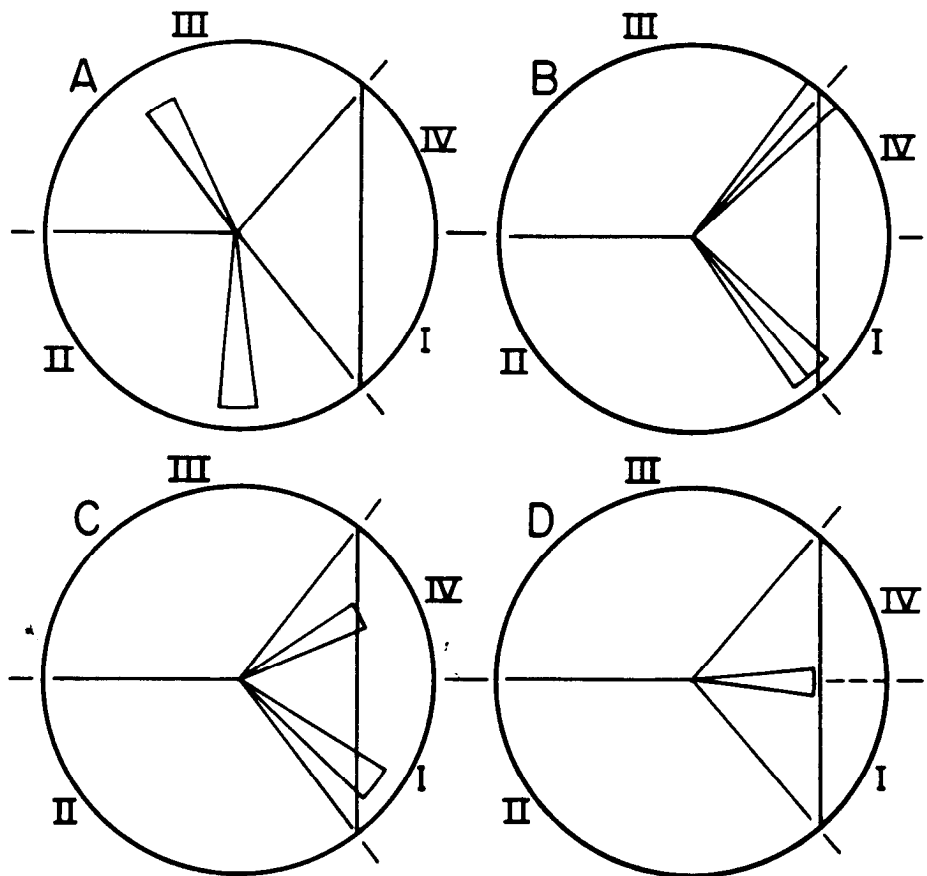

Figure 6. Diagrams of some of the ways in which a knot can fail to intersect a board or else only partially intersect or "graze" the board. (M 148 308)

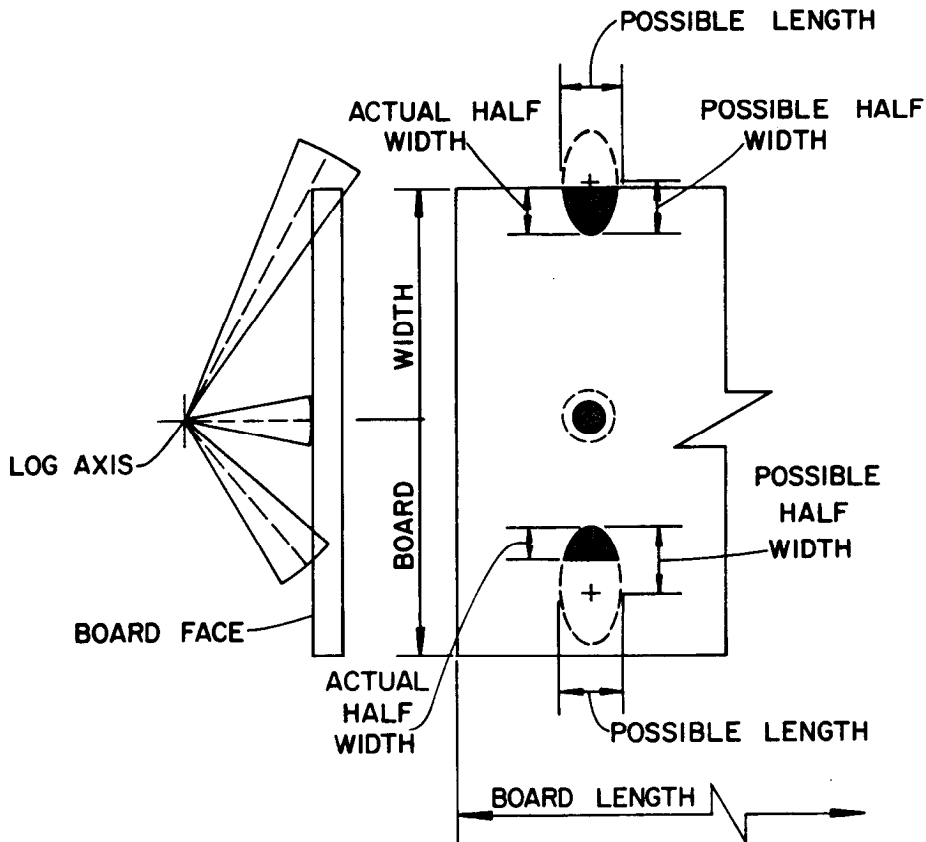

Figure 7. Diagram of how grazing knots partially intersect a board, together with their trace on the face of the board. (M 148 329)

TABLE 1.—The board grade assigned by PRICE based on the grade of each board face returned from subroutine GRADE

Grade of second board face	Grade of one board face				
	FAS	Selects ¹	1C	2C	Below 2C
FAS	FAS	—	FAS1F ¹	2C	Below 2C
Selects	—	1C	1C	2C	Below 2C
1C	FAS1F	1C	1C	2C	Below 2C
2C	2C	2C	2C	2C	Below 2C
Below 2C	Below 2C	Below 2C	Below 2C	Below 2C	Below 2C

¹ The NHLA Hardwood Standard Grades allow the option of grading using either the grade of "selects" or FAS1F. The FPL grading program was designed to use the "Selects" grade. This sawing simulation program uses the "FAS1F" grade which is determined as shown above.

board resulting from the last cut, the current best grade and surface measure, and which faces of the log have already been completely cut.

If the board grade resulting from the last cut did not drop below the current best grade, then the same face will be recut. If the log face has been completely cut (i.e., all boards between bark and central cant have been cut) or the board grade dropped, the log face with the best grade will be chosen as the next face to cut (the grade of a face completely cut has been set to an arbitrary value

which ensures that it will never be picked). A tie in grade is broken with surface measure (the surface measure value of a completely cut face has also been set to ensure it will not be picked). If a tie still exists-i.e., if all faces have the same grades and surface measures-the last one considered will be chosen. The face chosen is returned to the main program, or, if all faces are completely cut, a flag is set which indicates the log is completely sawn and control returns to the main program.

RERIP

Subroutine RERIP is particular to live rip sawing. It causes a rerip for grade to be performed on the current board if a core defect was found on the board outer face and the board originally grades below SELECTS (it is assumed that improvement in value is not likely if the board is already FAS or SELECTS). In addition, if the rerip does not improve the board value, it is not used (as if the rerip were never performed).

Subroutine CORE sets a flag if a core defect is found on the outer face of the current board. This flag is examined on entry to subroutine RERIP and, if not set, control is returned to the main program as no rerip will be performed. For reripping the core defect, width-coordinates (along the board width) on the board outer face become the rip locations. This results in a board which will be ripped into three sections (fig. 9). This is a good selection of rip locations but probably not optimum.

The middle section containing the core defect is arbitrarily assigned a grade of 3A/3B if it is wide enough for lumber (3 in.). If the rip locations cause the width of either "clear" side section to fall below 3 inches, that section is merged with the center and no rip is performed on that side. Subroutine RIP is called with any valid rip locations and returns the section grades. The process is repeated for the board inner face, with the exception that the rip locations from the outer face are used. Subroutine PRICE is then used to determine the value of the sections based on their grade and surface measure. If this rerip value is greater than the board value without rerip, the rerip value will be used for log evaluation, but the program keeps track of both values so that the value without rerip can also be used. Finally, if a rerip is performed, the amount of surface measure loss due to rerip is updated by the kerfs taken and the entire surface measure of any (merged) section which was below 3 inches in width. The rerip kerfs are taken from the center defective section.

Finally, the flag which indicated a core defect is reset and control returned to the main program.

RIP

Subroutine RIP makes "pseudo-boards" of the side sections defined by subroutine RERIP, converting the mathematical description of the current board in the defect arrays to the forms required by the grading program to grade each side section

separately.

Subroutine RIP first examines both sections to determine if either were found by subroutine RERIP to be too small for lumber. If so, no rip is performed on that side. The board description in the defect arrays is saved because these arrays are used to define the side section "pseudo-

boards" for the grading program. The defects located in each rip section are truncated at the rip locations and each side section is passed as a separate board face to the grading program. The defect arrays are then restored to their original values and the section grades returned to subroutine RERIP.

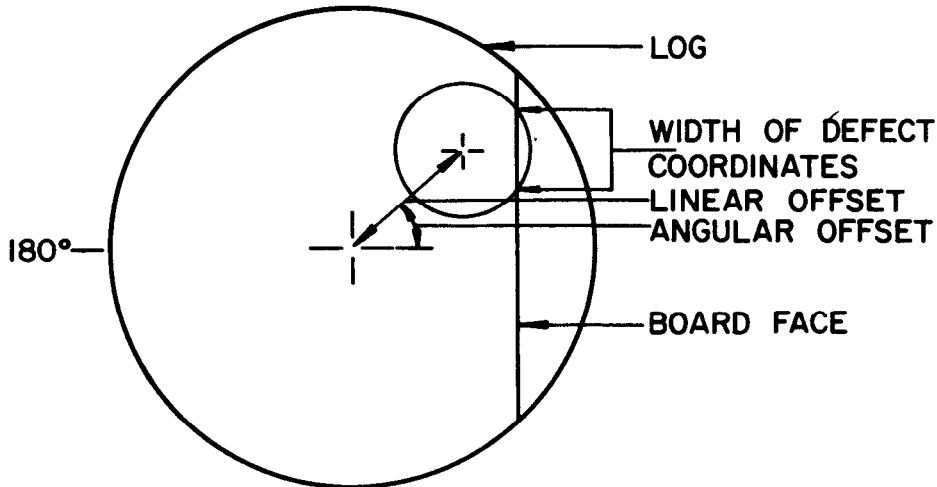

Figure 8. End view of a log with the cylindrical core defect not centered on the log axis (pith) but offset an appreciable distance. The computer program can handle this situation as well as the centrally located core defect.

(M 148 309)

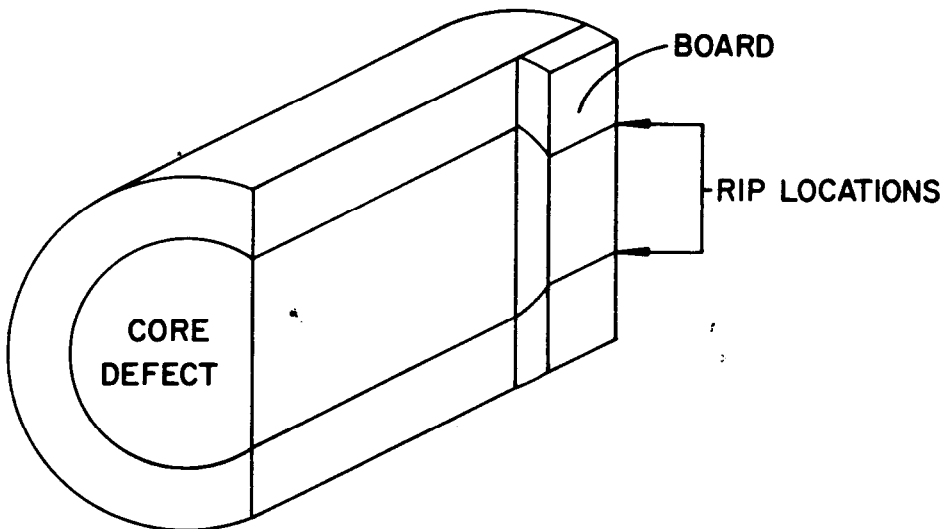

Figure 9. Cut away view of a log showing how the rip location in ripping for grade is referenced to the core defect on the outer face of the board. The kerf is taken out of the core defect. (M 148 330)

OTHERS IN THE SERIES

As indicated earlier, this USDA Forest Service Research Paper will be followed by two others that unite to cover computer simulation of hardwood log sawing. Identification of these additional research papers and their abstracts follow:

Res. Pap FPL 356--Lumber Values from Computerized Simulation of Hardwood Log Sawing by D. B. Richards, W. K. Adkins, H. Hallock, and E. H. Bulgrin.

Computer Simulation sawing programs were used to study sawing of mathematical models of hardwood logs by live sawing and three 4-sided sawing methods. One of the 0-sided methods duplicated "grade sawing" by sawing each successive board from the log face with the highest potential grade. Logs from 10 through 28 inches in diameter were sawn. In addition, a refinement in the live sawing called live-rip, in which center sawn boards are ripped to increase value, was studied.

Results generally indicate that all of the k-sided methods studied have similar lumber values. Live sawing was better than the 0-sided methods with good logs but inferior for 10- and 12-inch logs with large defective cores. Live sawing followed by ripping produced the highest lumber values in almost all cases.

Res. Pap, FPL 357--Programs for Computer Simulation of Hardwood Log Sawing, by W. K. Adkins, D. B. Richards, D. W. Lewis, and E. H. Bulgrin.

Four computer programs were developed at the University of Kentucky as simulation models for investigating factors affecting sawn log value over four hardwood sawing methods: Quadrant sawing, cant sawing, decision sawing, and live sawing with re-rip for grade. The programs are listed, along with information on the sawing methods, model assumptions, and program organization.

2.5-9-11-79

