

United States
Department of
Agriculture

Forest Service

Forest
Products
Laboratory

General
Technoal

FPL-44



FPL Design for Lumber Dry Kiln Using Solar/Wood Energy in Tropical Latitudes

John L. Tschernitz
William T. Simpson

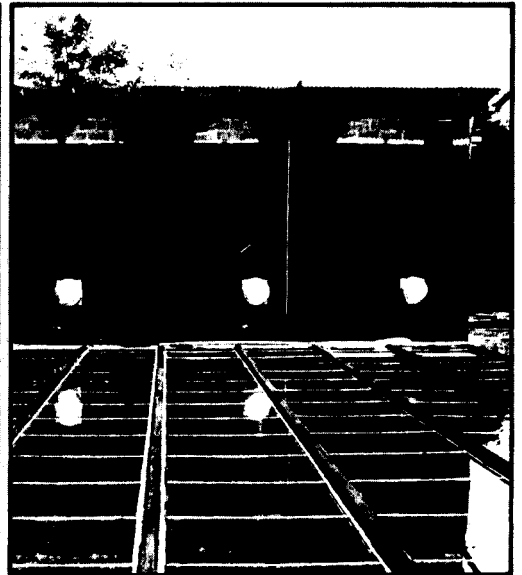
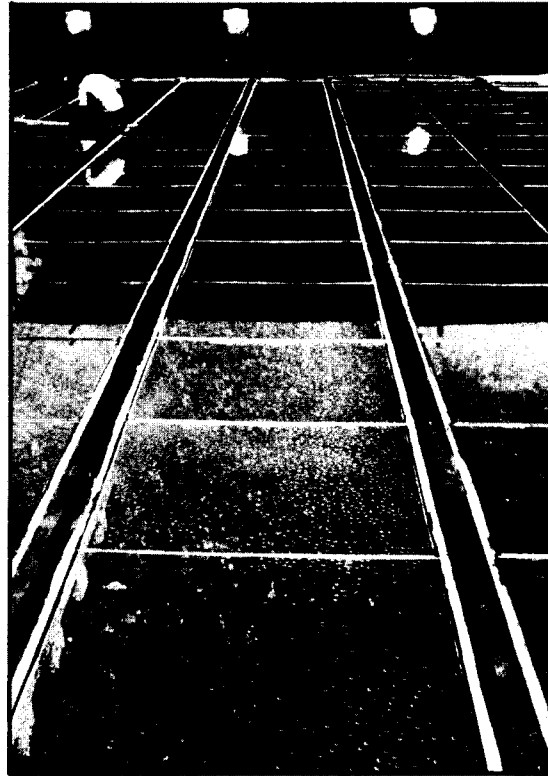

Abstract

Developing countries with a timber resource that can be manufactured into finished products either for local use or export often lack the capital to build high-cost dry kilns. Many of these countries are in the tropics where solar radiation and ambient temperatures are high. The low-cost solar/wood energy lumber dry kiln described in this report was designed and tested by the Forest Products Laboratory (FPL) for such countries where solar dry kilns can be built and operated at low cost.

The FPL design is for a 6,000-fbm capacity kiln having an insulated drying compartment, an external horizontal solar collector, and a furnace room containing a wood burner. Capacities larger or smaller than 6,000 fbm are also possible. This design allows collector and wood burner sizing to match the energy demands of the dryer. The design also incorporates low-cost controls that allow unattended drying when operated as a solar-only dryer. Manual firing is necessary when the wood-burning system is supplying the energy.

This kiln design is the final, commercial-size version established after years of testing several 1,000-fbm capacity prototypes. In December 1984 a kiln of this design was built in Sri Lanka at a factory that manufactures furniture and laminated beams from rubber and coconut wood.

Keywords: Solar, solar drying, wood energy, dry kiln, tropics, dryer.

April 1985

Tschernitz, John L.; Simpson, William T. FPL design for lumber dry kiln using solar/wood energy in tropical latitudes. Gen. Tech. Rep. FPL-44. Madison, WI: U.S. Department of Agriculture, Forest Service, Forest Products Laboratory; 1985.17 p.

A limited number of free copies of this publication are available to the public from the Forest Products Laboratory, P.O. Box 5130, Madison, WI 53705. Laboratory publications are sent to over 1,000 libraries in the United States and elsewhere.

The Laboratory is maintained in cooperation with the University of Wisconsin.

FPL Design for Lumber Dry Kiln Using Solar/Wood Energy in Tropical Latitudes

John L. Tschernitz, Chemical Engineer
William T. Simpson, Supervisory Research Forest
Products Technologist

Forest Products Laboratory, Madison, WI

Introduction

In 1975 the Forest Products Laboratory (FPL) began designing and testing low-cost solar dry kilns for small- to medium-sized production facilities in tropical developing countries. Several kiln designs were proposed, and one was selected from which three small-capacity prototypes were built and tested for operation and durability. This design was ultimately optimized so that a commercial-size kiln design could be proposed, a detailed description of which is contained in this report.

The project began when the U.S. Agency for International Development (USAID) asked FPL to investigate the use of solar energy to improve the drying practices of small- and medium-scale producers in developing countries, and to propose a kiln design if the technology was feasible, which it was (Tschernitz and Simpson 1977). We built a 1,000-fbm prototype at Madison, Wis. in 1977 (Simpson and Tschernitz 1984, Tschernitz and Simpson 1979) and tested it every summer since.

In 1981 we assisted in building a 1,000-fbm prototype funded by USAID, SRI LANKA, at a furniture factory in Sri Lanka, and it has been operating successfully since then (Simpson and Tschernitz 1982). In 1982 we assisted in installing another solar kiln of the same design funded by the United Nations Food and Agriculture Organization (UNFAO) at the Forest Research Institute at Yezin, Burma (fig. 1).

The design described in this report, along with the existing prototype, will provide the full kiln-drying needs of the furniture factory located near Horana in the southwestern quarter of Sri Lanka, 7° N latitude.

While the size chosen matches the factory's needs, the design can be built in smaller or larger versions. In early 1984 FPL signed an agreement with Borwood Ltd. of Colombo, Sri Lanka, with funding from the United Nations Development Program (UNDP), to provide the design details and technical consultation for construction, startup, and operation of the kiln, which was completed in December 1984.

A schematic diagram of the prototype kiln is shown in figure A-1. The caption is keyed to labeled kiln components in enough detail to illustrate the general operation of the kiln.



Figure 1.— 1,000-fbm (2.4-m³) capacity solar kiln at Forest Research Institute, Yezin, Burma. (M152096-1)

Description of the Dryer

General Principles of Operation

A schematic of the proposed dryer design is shown in figure A-2. It differs from the prototype in several ways: 1) the capacity is increased from 1,000 fbm (2.4 m³) to approximately 6,000 fbm (14 m³) of 1-inch- (25-mm) thick lumber with 3/4-inch (19-mm) stickers; 2) four collectors, instead of one, are located side-by-side delivering air into one large drying chamber; and 3) a wood residue burner has been added to allow drying 24 hours per day independent of solar insolation levels.

Air circulates through two intersecting loops, one through the collectors and/or residue burner, and the other through the wood package (fig. A-2). The wood package handles twice the flow volume of the collectors, which are two independent pairs of two parallel collectors. Airflow in each half of a collector pair is counter to the flow in the other half so that only one duct (C-fig. A-4) is necessary to carry air from the paired collectors to the manifold (D-fig. A-2). The four exhausters (K-fig. A-2) remove air (containing evaporated water) from the kiln at the leaving-air side (high humidity) of the wood package. The make-up air from outside enters the system at four points (J-fig. A-2) through the collectors (B-fig. A-2). This is done for three reasons: 1) the cooler ambient air lowers the temperature in the collector, and thus heat losses are decreased; 2) after the solar energy input no longer maintains the collector above dryer temperatures, the stored energy (collector above ambient temperature) can be used to preheat the incoming air; 3) the ambient temperature of the outside air with its lower humidity can purge the collector of high-humidity dryer air and thereby prevent or reduce condensation within the collector, particularly at night, which will increase its efficiency (energy is required to re-evaporate water at the beginning of the next diurnal cycle).

Heated air from the collectors is pulled into the dryer by two blowers (C-fig. A-2) and discharged (D-fig. A-2) directly into four overhead fans (E-fig. A-2) that circulate air through the stacked lumber.

Automatic control of the solar dryer is desirable, at the least possible cost, in order to accommodate 1) the intermittent delivery of solar energy to the collector; 2) variable relative humidities (RH) within the drying chamber, which will depend upon the ambient humidity and temperature in the chamber; and 3) the variable rate of drying of the wood. Without such controls, almost continuous manual observation would be needed to approach the quality and efficiency of drying attainable with automatic control. Controls include 1) two differential thermal comparators (F_c, F_d -fig. A-2) to sense the difference between dryer and collector temperatures and turn the solar blowers (C-fig. A-2) on and off accordingly; 2) a humidistat (RH1-fig. A-2) to allow automatic venting as needed because controlled venting increases thermal efficiency and also permits scheduling high RH's early in drying and low RH's later

on; 3) a second humidistat (RH2-fig. A-2) to establish a maximum RH above which the dryer will shut down. This might happen during long periods of low-solar input and high humidities, i.e. rainy periods, and is particularly important when the wood is below 20 percent moisture content; and 4) a third humidistat (RH3-fig. A-2) has two functions: a) control the humidifier (G-fig. A-2) for conditioning at the end of the drying run, and b) raise the relative humidity in the drying chamber in order to prevent or reduce degrade in refractory woods at intermediate moisture contents.

A low-cost combustion system fueled by wood has been incorporated in the solar dryer design. A simple burner is located in a furnace chamber on the opposite side of the drying compartment from the solar collector (A-fig. A-2). The furnace can operate either simultaneously or separately from the solar collector.

Construction Details of the Dryer

Figures A-3 through A-8 provide a description of the important construction details of the kiln:

- Figure A-3 - Plan view of entire kiln
- Figure A-4 - Section view of entire kiln
- Figure A-5 - Section view of solar collector ducts
- Figure A-6 - Section view of solar collector
- Figure A-7 - Elevation view of furnace room
- Figure A-8 - Wiring diagram of control system

Solar collector (fig. A-6).—The collector is external to the drying compartment so that collector area and orientation are not limited by the geometry of the dryer. The collector is horizontal (except for a 1/2 degree north-south drainage tilt) and is built into the ground for ease and low cost of construction. The horizontal orientation is particularly effective near the equator.

Figure A-6 is an end cross section of one of the two pairs of collectors. A foundation of concrete blocks or poured concrete form the perimeter of the collector. A 12-inch- (0.3-m) deep excavation is filled with gravel to approximately 6 inches (0.15 m) of the top of the block or concrete foundation. A layer of charcoal pieces sized to 0.5-1 inch (1.3-2.5 cm), about 2-3 inches (5.1-7.6 cm) thick, covers the gravel. Charcoal is an inexpensive energy-absorbing surface and heat-transfer medium and a good insulator that reduces heat loss to the ground. The interior surfaces of the foundation are painted flat black. The collector cover spans the 4 feet between sections of the foundation.

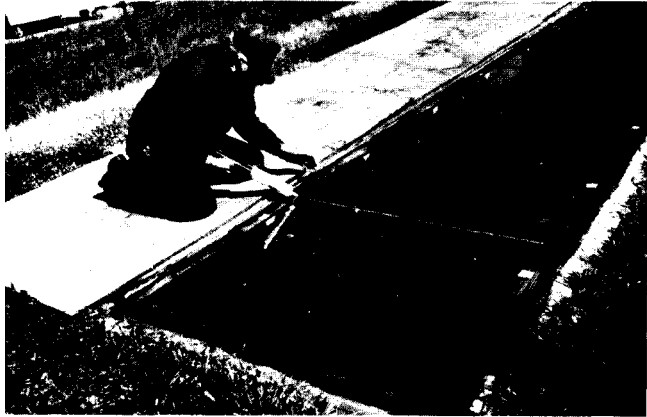

Figure 2.—Glass collector cover on prototype kiln. Wood sills shown in this photo are not included in the design of the 6,000-fbm kiln. (M830178-8)

Experience with the prototype indicates that common window glass will be the most cost effective collector cover, particularly in areas without access to rigid plastic cover material. The sections of glass making up the cover are installed to overlap (0.5 inch, 1.3 cm) as shingles do (fig. 2). Butyl sealant tape and silicone sealant are used to seal the glass directly to the block or concrete, foundation. One feature of this construction method is avoidance of the expense and possible decay of wood frames for the glass. Individual sections of glass are replaceable simply by cutting the sealant around the edges.

The collector is 50 feet (15 m) long, and each section is approximately 4 feet (1.2 m) wide. Because of overlap at the edges, the effective collector area is approximately 1,500 square feet (136 m²). The ratio of lumber capacity to collector area is 4 fbm per square foot (0.1 m³/m²). In each of the four collectors air is drawn from the drying compartment and/or fresh air intakes (J-fig. A-2), travels the length of one side of the collector, crosses over to the other side through the 4-foot-long gap at the end, and then travels down that side to the collector and back into the drying compartment through the ducts shown in figure A-5. Blowers (C-fig. A-2) induce airflow through the collector and into the drying compartment to the manifold that discharges the heated air just behind fans for internal circulation. The collector is under negative pressure so that any leakage is into the system.

Drying compartment. —The inside dimensions of the drying compartment are approximately 10 by 34 by 11 feet high (3 by 10.4 by 3.3 m). The kiln is track loaded and is designed for a 5-foot-wide load of lumber (fig. A-4). The walls are of 12- by 12- by 24-inch concrete block, hollow and filled with loose insulation. The ceiling of the drying compartment consists of 2- by 4-inch (50- by 100-mm) boards on edge (figs. A-4, A-5). This provides good insulation and a solid

ceiling for attachment of fans and other kiln components. Above the 2 by 4 ceiling is a built-up roof with sealed surfaces and space for insulation. Above that an open-pitched shed-type roof of corrugated metal painted black serves the dual role of providing for water runoff and as a pre-heater for makeup air entering the solar collector (figs. A-2, A-4).

Wood residue burner. —Wood residue is burned in a simple, low-cost burner housed in a furnace chamber on the side of the drying compartment opposite the solar collector (figs. A-3, A-4, A-7). The burner consists of two double-wall 55-gallon steel drums mounted on a framework. One drum is the combustion chamber. The other, along with the chimney, serve as additional heat transfer surfaces. The burner operates at 65 percent efficiency and can produce up to 80,000 Btu/hour (23 kW) (Anonymous 1981). A blower (fig. A-4) discharges kiln air into the furnace chamber, and forces heated air from the furnace room back through a duct into the drying compartment. When humidity control is necessary, a humidistat (RH3-fig. A-2)-activated water spray can release water into the furnace chamber for mixing with air going to the drying compartment. A manifold within the drying compartment distributes heated air into the internal circulating air.

Table 1 lists the major building materials for the kiln.

Table 1.—List of major building materials for solar/wood energy kiln

Item	Amount
Poured concrete for foundations and footings	26 yd ³ (20 m ³)
Concrete blocks—12 x 8 x 24 in. (0.31 x 0.20 x 0.62 m)	1,200 blocks
Roof-decking boards—2 in. x 4 in. x 11 ft (0.051 x 0.102 x 3.35 m)	205 boards
Loose-fill insulation	625 ft ³ (17.7 m ³)
Kiln coating	1,400 ft ² (130 m ²) coverage
Plastic film (black) for collector	1,600 ft ² (149 m ²)
Charcoal	14 yd ³ (10.7 m ³)
Gravel	9 yd ³ (6.9 m ³)
No. 5 concrete-reinforcing bar	150 ft (45.7 m)
Steel I-beam for furnace room roof (W8 x 24)	8.5 ft (2.6 m)
Glass (3/16 in. (4.7 mm) thick)	1,485 ft ² (138 m ²)
Corrugated roof	
Steel	532 ft ² (49.4 m ²)
Asbestos	280 ft ² (26.0 m ²)
55-gallon drums	2
Butyl automotive sealant	1,200 ft (366 m)
Silicone sealant	120 tubes
Steel header	30 ft (9.1 m)
Angle iron	as needed
Sheet metal	as needed
Lumber	as needed
Fasteners	as needed

Energy Supply and Demand

Energy supply and demand estimates can be made on an annual basis for the 6,000-fbm kiln for drying 1-inch-thick rubberwood in Sri Lanka, as summarized in tables 2 and 3. Table 2 summarizes a 7-day drying schedule, and table 3 contrasts a slower 10-day schedule where proportionately more solar than wood energy can be used. There are also many other possible similar schedules. In each schedule there are three sources of energy supply: solar (based on 1,500 ft² of collector operating at 50 pct efficiency), wood residue (one burner rated at 80,000 Btu/hr), and electrical energy from the fan and blower motors. Assuming that the normal mode of operation will make maximum use of solar energy for a given schedule and supplement with wood residue to supply the rest, the 7-day schedule will use 41 percent solar, 46 percent wood residue, and 13 percent electric; the 10-day schedule will use 62 percent solar, 18 percent wood residue, and 20 percent electric. Thus, if one is willing to increase drying time, use of wood residue can be reduced. If one needs to minimize drying time, then proportionally more wood residue energy can be used. Electric energy might be reduced by not operating two of the four fans late in drying when air circulation requirements are reduced.

Table 2.—Energy supply and demand estimates (average annual basis) for solar/wood energy dry kiln for operation in southwestern Sri Lanka, drying 6,000 fbm of 1-inch-thick rubberwood from 60 to 13 percent using a 7-day (168-h) schedule

Schedule 1 ¹	Energy at times of				
	² 168 h (pct)	24 h	³ 12 h	⁴ 1 h	
	----- Btu x 10 ⁶ -----				
supply					
Solar (1,500 ft ² collector at 50 pct efficiency)	6.09 (41)	0.87	0.87	0.250	
Wood residue burner	⁵ 13.44 (46)	1.92	0.96	0.080	
Electric (fan/blower motor)	1.99 (13)	0.28	0.14	0.012	
Total	21.52	3.07	1.97	0.342	
Demand					
Maximum	—	3.21	1.60	0.133	
Average for 168 hours	15.01 (100)	2.14	1.07	0.089	
¹ Moisture content (pct)	temperature (°F)	relative humidity (pct)			
60-50	110	80			
50-30	120	50			
30-15	130	30			
15-13	140	30			

²Total drying time to 13 pct moisture content.

³Daylight hours.

⁴Maximum hourly rate at solar noon.

⁵If the full 6.09 x 10⁶ Btu of net available solar energy is utilized, then the net wood residue is 6.93 x 10⁶ Btu.

Table 3.—Energy supply and demand estimates (average annual basis) for solar/wood energy dry kiln for operation in southwestern Sri Lanka, drying 6,000 fbm of 1-inch-thick rubberwood from 60 to 12 percent using a 10-day (240-h) schedule

Schedule 2 ¹	Energy at times of				
	² 240 h (pct)	24 h	³ 12 h	⁴ 1 h	
	----- Btu x 10 ⁶ -----				
supply					
Solar (1,500 ft ² collector at 50 pct efficiency)	8.70 (62)	0.87	0.87	0.250	
Wood residue burner	⁵ 19.20 (18)	1.92	0.96	0.080	
Electric (fan/blower motor)	2.84 (20)	0.28	0.14	0.012	
Total	30.74	3.07	1.97	0.342	
Demand					
Maximum	—	2.50	1.25	0.104	
Average for 240 hours	14.07 (100)	1.41	0.70	0.058	
¹ Moisture content (pct)	temperature (°F)	relative humidity (pct)			
60-50	100	80			
50-30	110	50			
30-15	115	30			
15-12	120	40			

²Total drying time to 12 pct moisture content.

³Daylight hours.

⁴Maximum hourly rate at solar noon.

⁵If the full 8.70 x 10⁶ Btu of net available solar energy is utilized, then the net wood residue is 2.53 x 10⁶ Btu.

Control and Operation of the Kiln

The kiln is designed to operate automatically except for the burner that must be charged manually. A range of operating variables can be changed by manipulating set points. This provides a means to control drying according to a schedule.

Solar-Only Operation

Daily Control Sequence

A description of events in a typical 24-hour control sequence will illustrate how the dryer operates. Following that, a detailed description of the control equipment and a wiring diagram of the control circuit will be presented.

0000-0800 hours. -The timer (fig. A-8) opens the control relay, and the kiln is turned off.

0800 hours. -The timer closes the control relay (R1-fig. A-8) if the RH in the dryer is below the RH2 set point (the upper limit of RH set by RH2 in fig. A-2). The internal fans are on. The power vents (K-fig. A-2) are on if the RH in the dryer is above RH1 set point.

0800-2200 hours. —The solar blowers (C-fig. A-2, fig. A-8) start when the temperature in the collector (F-fig. A-2) is above the temperature in the drying chamber (F_d -fig. A-2) (Deko Lab control-fig. A-8). Simultaneous with the solar blower operation, the dampers (H-fig. A-2, fig. A-8) open to permit continuous circulation of air from the dryer through the collector and back into the dryer through the duct (D-fig. A-2) behind the fans (E-fig. A-2). When the solar blowers are off, the duct that takes air from the drying chamber into the collectors must be dampered. Dampering prevents the loss of energy through induced circulation, by fan head, of warm air from the drying chamber through the cool collector. The electrical input to the solar blowers is in front of the control relay (R1-fig. A-8) so that the solar blowers (C-fig. A-2, fig. A-8) can be activated if they have been shut off by high RH (RH2-fig. A-2, fig. A-8). This is important because when sufficient solar energy becomes available to heat the air in the collector, it lowers the RH of the air entering the drying chamber. When the RH falls below the set point (RH2) the dryer turns on automatically.

The differential temperature controls (F_c/F_d -fig. A-2, Deko Lab control-fig. A-8) activate the solar blowers intermittently throughout the drying day (times between 0800 and 2200, or other time as set by the timer) whenever the temperature in the collector is higher than the drying chamber. When the solar blowers are *OFF*, the fans and exhaust blowers will continue to operate. Drying can proceed without solar heat input into the collector because of energy storage in the wood/dryer system, the drying capacity of the ambient air, and the stored energy in the collectors. The stored energy can be recovered by preheating, i.e., scavenging of the collector with the vent air entry induced by the exhaust blowers.

If the RH falls below set point RH1 (some time between 0800 and 2200, or other time as set by the timer), the humidifier (G-fig. A-2, fig. A-8) is activated by its own humidistat (RH3) to increase the RH.

2200-2400 hours. —The dryer will normally stop operation. Since the dampers (H-fig. A-2, fig. A-8) are closed (solar blowers have been off) the drying chamber will be isolated from the collectors and overnight heat loss is minimized. A thermostat is located in parallel with the timer/relay circuit (fig. A-8). If at 2200 hours (or other time set by the timer) the temperature in the chamber is greater than 90 °F (32 °C), or other variable setting, the drying will continue until the temperature drops below 90 °F (32 °C) or the humidity rises above set point RH2. The cycle will be repeated again at 0800 hours the next day.

Operating Controls

Timer. —The set points, *ON* and *OFF* time for any 24-hour day, can be changed to meet local solar drying conditions. The timer can also be bypassed manually (switch S5-fig. A-8).

Differential temperature switch—Deko Lab. —The solar blowers can be controlled manually by the bypass switches (S7,S8-fig. A-8). The Deko Lab controls will activate the solar blowers at collector temperatures in the difference range of 2 to 20 °F (1.1 to 11 °C) (difference between F_c and F_d in fig. A-2, as adjusted by setscrew) above the dryer temperature. For dryer operation the differential should be about 5 °F (2.8 °C). (Trial/error set-screw selection).

Relative humidity control. —All set point selection is manual with the dryer. The set point of RH1 can be changed continuously from 0 to 100 percent RH. This switch is closed above set point and controls the exhaust blower (an arbitrary scale that can be calibrated for higher accuracy). At temperatures above 120 °F (49 °C), a slight temperature shift in this scale will be noted. Customarily, the set point will be high initially and low in the final stages of drying, particularly for refractory woods.

RH2 is similar to RH1, except the switch is open (*OFF*) above set point. The switch controls the power relay. This control is used to maintain humidities below a certain maximum level, which may be necessary during a series of cloudy days in order to prevent the moisture increase in the already low-moisture wood.

RH3 operates the humidifier (compressor-spray nozzles) and is similar to RH1, except the switch is open (OFF) above set point. The drying chamber can be controlled to maintain the humidity above a minimum level by means of this humidifier. In order to humidify, the switch (S4-fig. A-8) must be closed to activate RH3 for control of the humidifier and solenoid water valve. The control point on RH3 can be varied over a wide range. If drying stresses are present at the end of the drying run, the humidifier can be used to accomplish a conditioning stress relief period. At RH's in the chamber greater than 85 percent and temperatures in excess of 110 °F, stress relief can be accomplished in 1 to 3 days (solar) depending upon the wood properties, thickness, and/or degree of stress.

Table 4.—Electric switches (refer to fig. A-8)

Switch	Function
S5B	Thermostat cutoff (timer bypass)
S7, S8	Line bypass of Deko Lab controls for solar blower
S12, S13, S14, S15	Manual ON/OFF for internal fans
S16, S17	Manual ON/OFF for solar blowers
S5	Timer bypass
S5A	ON/OFF timer contact
S6	Bypass RH2
S4	Manual ON/OFF for humidifier
S4A	Bypass RH3
S9	Manual ON/OFF for exhaust
S3	Bypass RH1
S18	Furnace blower ON (Position 1) or controlled by RH3 (Position 2)
S19	ON/OFF kiln lights
S10	Main disconnect
RH1 ¹	Honeywell humidistat H404 A 1003 Closes on rise of RH above set point
RH2 ¹	Honeywell humidistat H404 C 1019 Opens on rise of RH above set point
RH3 ¹	Honeywell humidistat H404 C 1019 Opens on rise of RH above set point

¹Located within solar dryer.

Table 5.—Control panel operational modes (refer to fig. A-8)

Switch	Automatic mode	Manual mode
S5B	Closed ¹	Open ²
S7, S8	Position 6	Position 5
S12, S13, S14, S15	Closed	Closed
S16, S17	Closed	Closed
S5	Open	Closed
S5A	Closed	Open
S6	Open	Closed
S4	Closed or open	Closed
S4A	Open	Closed or open
S9	Closed	Closed or open
S3	Open	Closed
S18	Position 2	Position 1 or 2

¹Closed—power ON.

²Open —power OFF

Air circulation. —Four single-speed fans are controlled by the timer, RH2, thermostat, and manual switches (S12-15-fig. A-8). The fans can be operated together or separately, and in the later stages of drying when air circulation requirements decrease, it will be economical to switch two of the four fans off for reduced energy consumption.

Control of Various Components

Timer— variable ON/OFF by time of day, or manual switch (S5A-fig. A-8).

Solar blower— Deko Lab TC-3 thermal switch or manual switches (S7,S8-fig. A-8).

Fans— Timer, RH2, or manually (switches S12-15-fig. A-8).

Exhaust vents— RH1, timer, RH2, or manual switch (S9-fig. A-8).

Humidifier— RH3 or manual switch (S4-fig. A-8).

Dampers— Deko Lab thermal switch or manual switch (switches S7, S8-fig. A-8).

Furnace blower— RH3 or manual switch (S18-fig. A-8).

Table 4 summarizes the electric switches in the control system (with reference to fig. A-8). Table 5 summarizes switch positions for automatic or manual operation. Table 6 is a list of required electrical equipment.

Supplemental Wood Fuel Operation

Table 6.—Electrical equipment list

Figure 3	Item	Quantity
C	Solar blower, 18-1/8-inch wheel diameter, 3,750 CFM free air delivery at 467 RPM, 1 hp, 220 V*, 50 Hz, totally enclosed fan-cooled motor.	2
E	Internal fans, 30-inch-diameter blades, 11,000 CFM free air delivery at 690 RPM, 1 hp, 220 V*, 50 Hz, totally enclosed fan-cooled motor.	4
K	Exhaust ventilators, 12-inch-diameter blade, 940 CFM free air delivery at 1,500 RPM, 1/10 hp, 110 V, 60 Hz, sealed motor.	4
	Step down auto transformer 220-115 V, 1.7 kVA (for exhaust ventilators).	1
	Furnace blower, direct drive, 9-inch wheel diameter, 1,390 CFM at 1-1/2-inch static pressure and 1,725 RPM, 1 hp *, 220 V, 50 Hz, totally enclosed fan-cooled motor.	1
H	Honeywell damper motor model M346A1140, 230 V, 50 Hz.	4
RH1	Humidistat that switches OFF when humidity falls to set point, 220 V.	1
RH2, RH3	Humidistat that switches ON when humidity falls to set point, 220 V.	2
F _c , F _d	Differential temperature controller, 230 V, 50 Hz.	2
	Timer (24 hr), 230 V, 50 Hz.	1
	Relay (R2-fig. A-8), 1-1/2 hp, 230 V, 50 Hz.	1
	Contacter (R1-fig. A-8), 7-1/2 hp, 230 V, 50 Hz.	1
	Solenoid valve (fig. A-8), 230 V, 50-60 Hz.	1
	Compressor for humidifier, 1/2 hp, 230 V, 50 Hz, 4-1/2-gallon tank.	1
	Thermostat, remote sensing, SPDT, range should cover at least 30 to 90 °F.	1

* Optional 440V, 3ø

A simple wood waste fuel combustion system has been incorporated into the solar drying system. It consists of two 55-gallon steel drums, mounted on a framework, as the combustion chamber and heat transfer surfaces (figs. A-2, A-3, A-4, and A-7). The purpose of this adjunct system is to increase the drying throughput of the kiln by operating 1) at night, 2) on cloudy days, and 3) during rainy periods. The auxiliary furnace can operate simultaneously with the solar collector in the following way. The solar blower is only activated when the collector is warmer than the kiln chamber. Thus, if the furnace has heated the drying chamber higher than the discharge temperature of the collector, the solar blower will stop and the dampers (H-fig. A-2) will close. Two events then follow: 1) When the RH1 control calls for venting, fresh air is drawn through the collector to be preheated (J, B-fig. A-2), thereby recovering any solar energy accumulating in the collector when the blower is off, even though the collector is now at a lower temperature than the dryer. 2) At low vent rates the collector temperature may again rise above the kiln "control" temperature, and the solar blower will start. The energy input from the furnace will be varied manually from the maximum to lower levels by damper control of combustion air to the drum and with the amount and quality of fuel charged to the furnace. Observation of temperature in the furnace house and/or the kiln will guide the operator in the manual firing of the combustion chamber. If for some reason the temperature in the kiln rises to levels felt injurious to the wood, a discharge vent (furnace heat bypass-fig. A-4) can be opened to cool the system.

The steel drums will probably need to be replaced frequently because corrosion will perforate the drum wall. This compromise is made with the assumption that steel drums are readily available, and that even with frequent replacement the cost will be less than with a more durable but more expensive burner. If a different combustion unit is substituted, the operation of the blockhouse furnace chamber (A-fig. A-2) would still be maintained.

If it is necessary to raise the humidity at certain stages of the drying cycle (RH3 control), a pneumatic atomizer (G-fig. A-2, fig. A-8) has been installed in the furnace chamber to spray water onto the heated drums. The evaporated water is then introduced along with the heated air into the kiln. If the furnace is not in operation when it is necessary to raise the humidity in the dryer, the atomizer is still activated by RH3. In addition, when switch S18 (fig. A-8) is in the correct position, the furnace blower will also be activated by RH3 so that the humidified air is circulated from the furnace room to the drying chamber.

Waste wood fuel should be inventoried in order to provide for air drying and thus more efficient combustion and higher heat release from the lower moisture content wood. It may be desirable to use the solar dryer itself to predry fuel between wood charges should the inventory of air-dried fuel be low.

Construction of Kiln

In August 1984 kiln control equipment (fans, blowers, motors, various sensors, etc.), and special sealants for the glass collector, were shipped from the United States to Sri Lanka. Concurrently, the staff of Borwood, Ltd. began construction of the kiln structure using local building materials. In early November, the authors arrived in Sri Lanka to help in final construction details and assure proper operation. The kiln was completed in early December. Figure 3 shows the kiln shortly before completion.

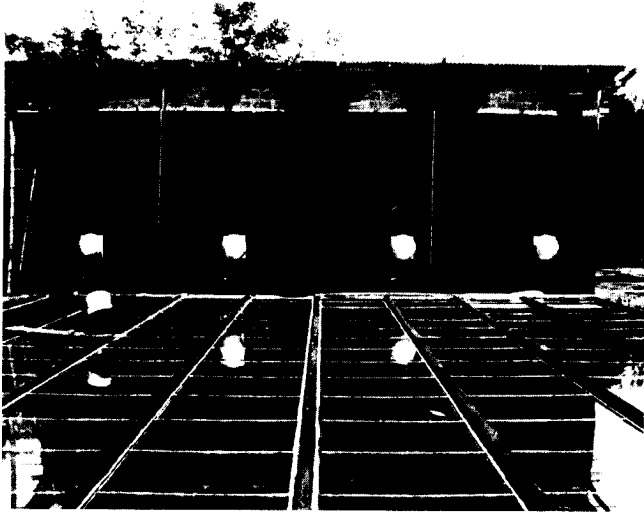

Figure 3.—Partially completed 6,000 fbm solar/wood energy dry kiln at Borwood Ltd., near Colombo, Sri Lanka. (M84-0506-11)

Summary

The FPL design for the solar/wood energy dry kiln described in this report is the culmination of a project that included design, construction, and testing of several small prototype kilns. Observation of prototype performance suggested several design changes. The final design is commercial size (for small-medium size operations in tropical developing countries) and incorporates design improvements suggested by prototype performance.

The specific design is for 6,000 fbm (14 m³) capacity, although within practical limits the design is modular in 3,000 fbm (7 m³) increments. The kiln consists of three major components: 1) a glass-covered collector built horizontally into the ground; 2) a separate drying compartment; and 3) a furnace room housing a wood residue burner. The basic design philosophy was to provide as much automatic control as practical using low-cost industrial controls. The combination of solar and wood waste energy allows 24 hours per day drying regardless of weather.

The design was intended specifically for a furniture laminated beam factory near Colombo, Sri Lanka. The kiln was built in December 1984, and is now operational.

Literature Cited

Anonymous. The return of the wood stove. Consumer Reports. 46(10); 1981.

Simpson, W. T.; Tschernitz, J. L. Solar dry kiln gets trial in Sri Lanka. World Wood. 23(1): 13; 1982.

Simpson, W. T.; Tschernitz, J. L. Solar dry kiln for tropical latitudes. Forest Products Journal. 34(5): 25-34; 1984.

Tschernitz, J. L.; Simpson, W. T. Solar kilns: Feasibility of utilizing solar energy for drying lumber in developing countries. USAID FPL-AID-PASA TA (AG 02-75). Washington, DC: U.S. Department of Agriculture, Forest Service; 1977.

Tschernitz, J. L.; Simpson, W. T. Solar-heated, forced-air lumber dryer for tropical latitudes. Solar Energy. 22: 563-566; 1979.

Acknowledgment

We thank the following staff at FPL Tedd Mianowski, technician; Doug Hall and Dennis Rose, electricians; and Mike Statz, draftsman, for their valuable contributions to this project.

In particular, we wish to acknowledge Hope Todd, Director of Borwood, Ltd., for his interest in this project as well as his management of the financing and construction of the solar kiln at Horana; and C. Dassanayake, Engineer at Borwood, for his effective efforts in directing the technical details of construction.

Appendix
Schematics (figs. A-1 through A-8)

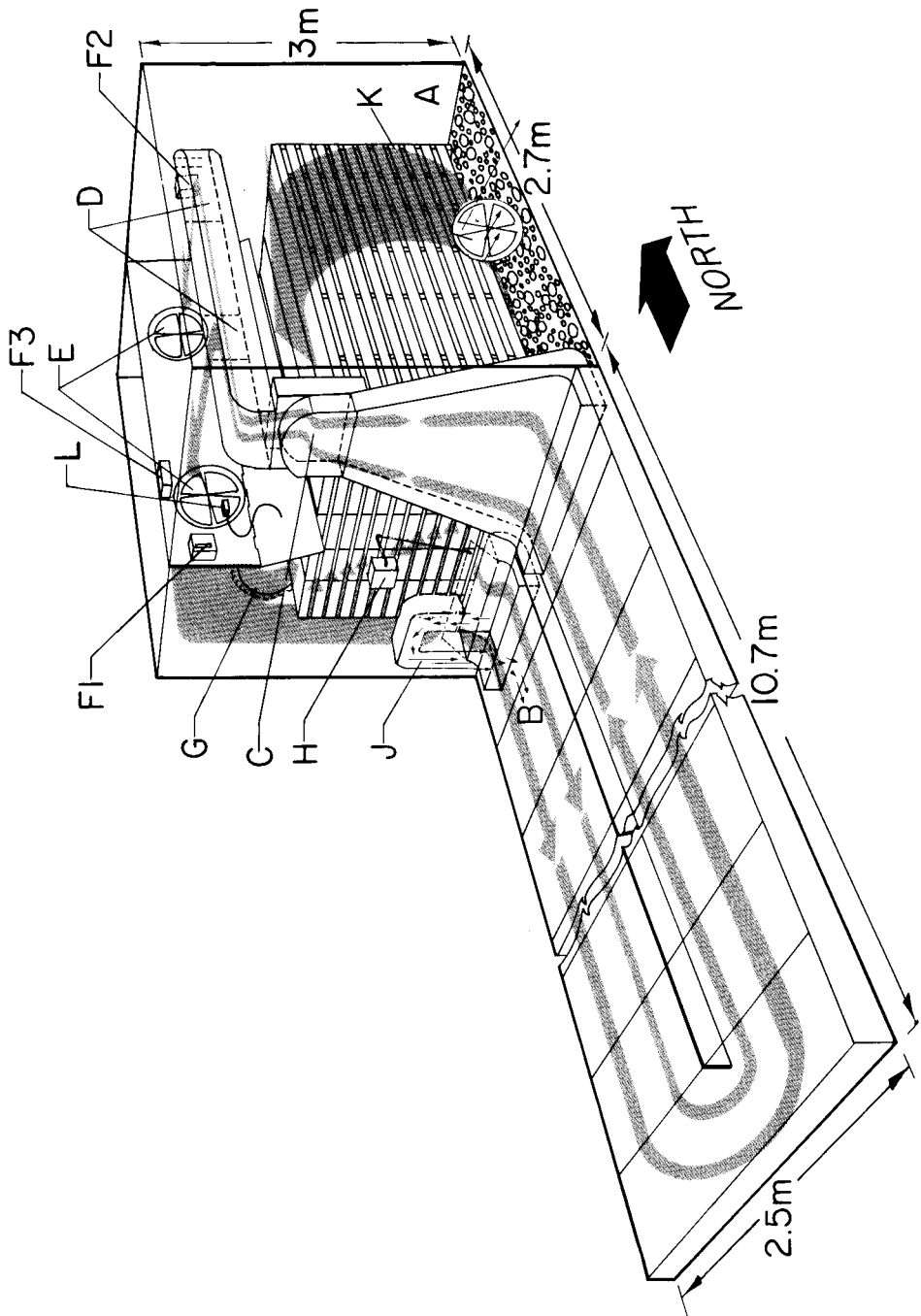

Figure A-1.—Schematic of solar dry kiln: (A) Drying chamber; (B) Solar collector; (C) Blower to induce air flow through the collector; (D) Hot air discharge to internal fans; (E) Internal fans; (F1) Humidistat for ventilator; (F2) Humidistat for upper limit control; (F3) Humidistat for humidifier; (G) Disk humidifier; (H) Damper motor for dryer-collector interchange or isolation; (J) Fresh air intake; (K) Power exhaust; (L) Thermostat. (M152098)

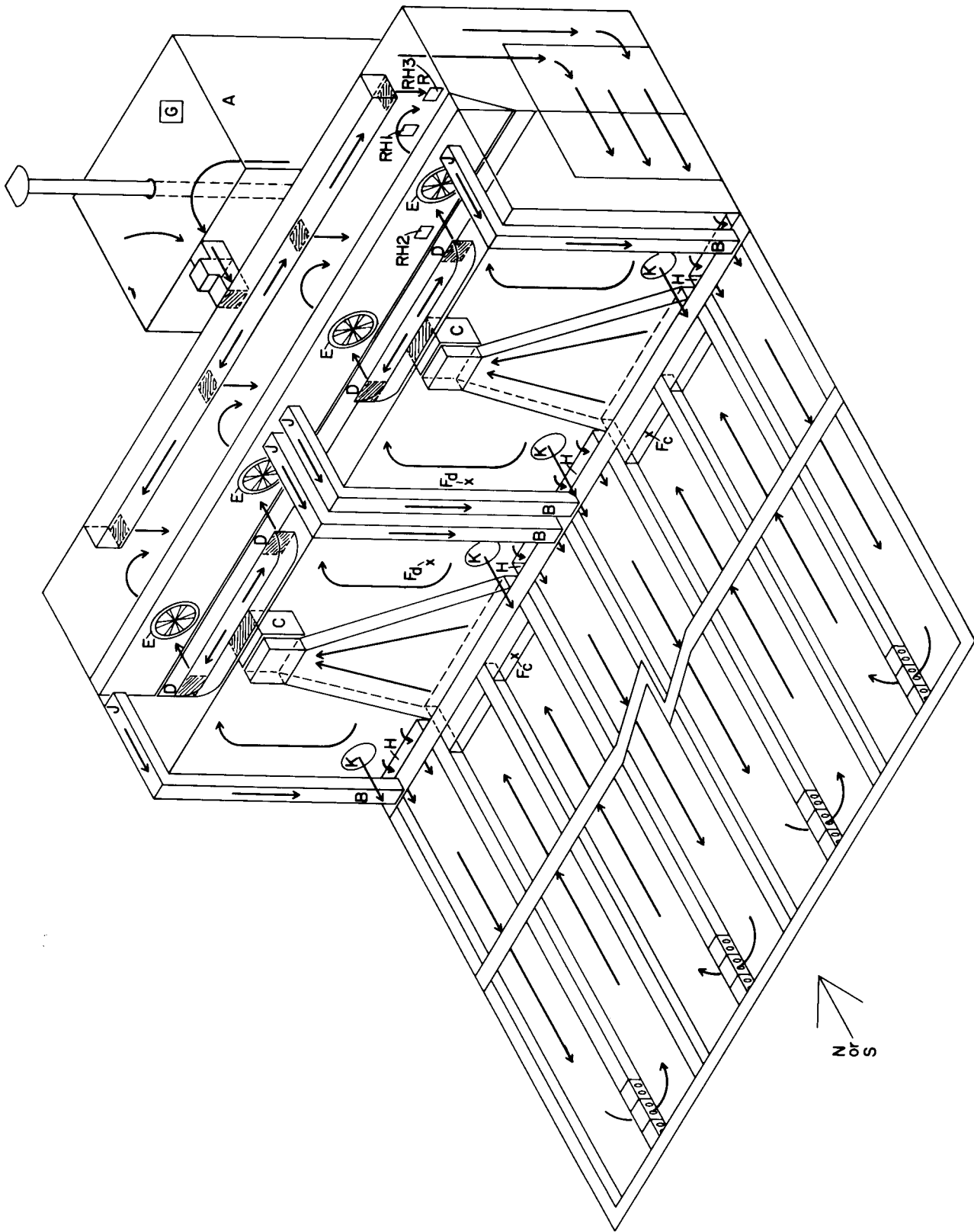

Figure A-2.—Schematic diagram of solar/wood residue dry kiln: (A) Furnace room; (B) Intake air enters collector; (C) Solar blower; (D) Manifold ducts for solar-heated air; (E) Internal fans; (F_c) Differential temperature sensor - collector; (F_{c'}) Differential temperature sensor - dryer; (G) Humidifier; (H) Return air duct from dryer to collector (dampered); (J) Entry point of intake air; (K) Exhaust vents; (RH1) Humidistat (for exhaust vents K); (RH2) Humidistat (for shutting off kiln at high humidity); (RH3) Humidistat (for humidifier G). (ML845651)

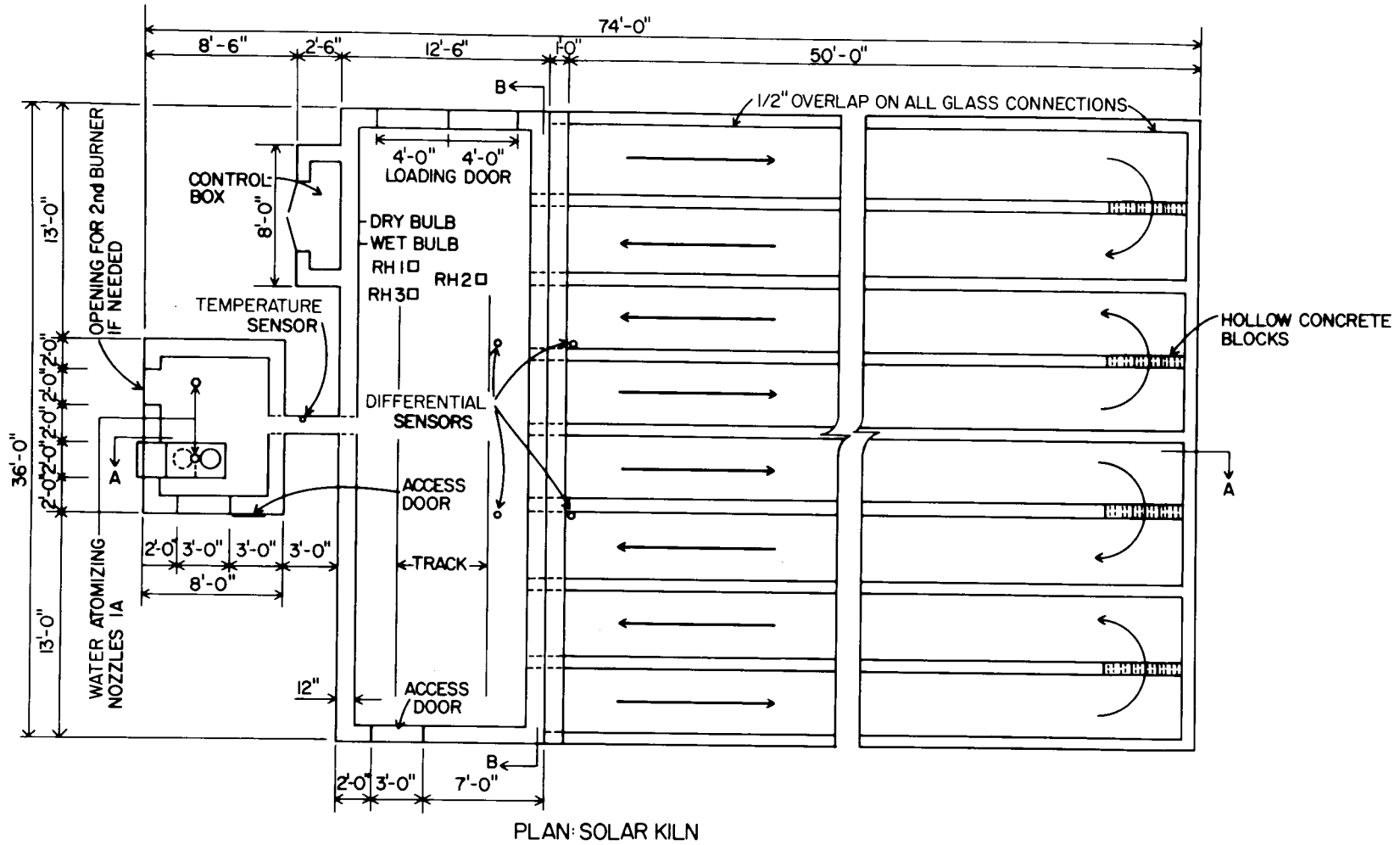

Figure A-3.—Plan view of solar/wood residue kiln. (ML845653)

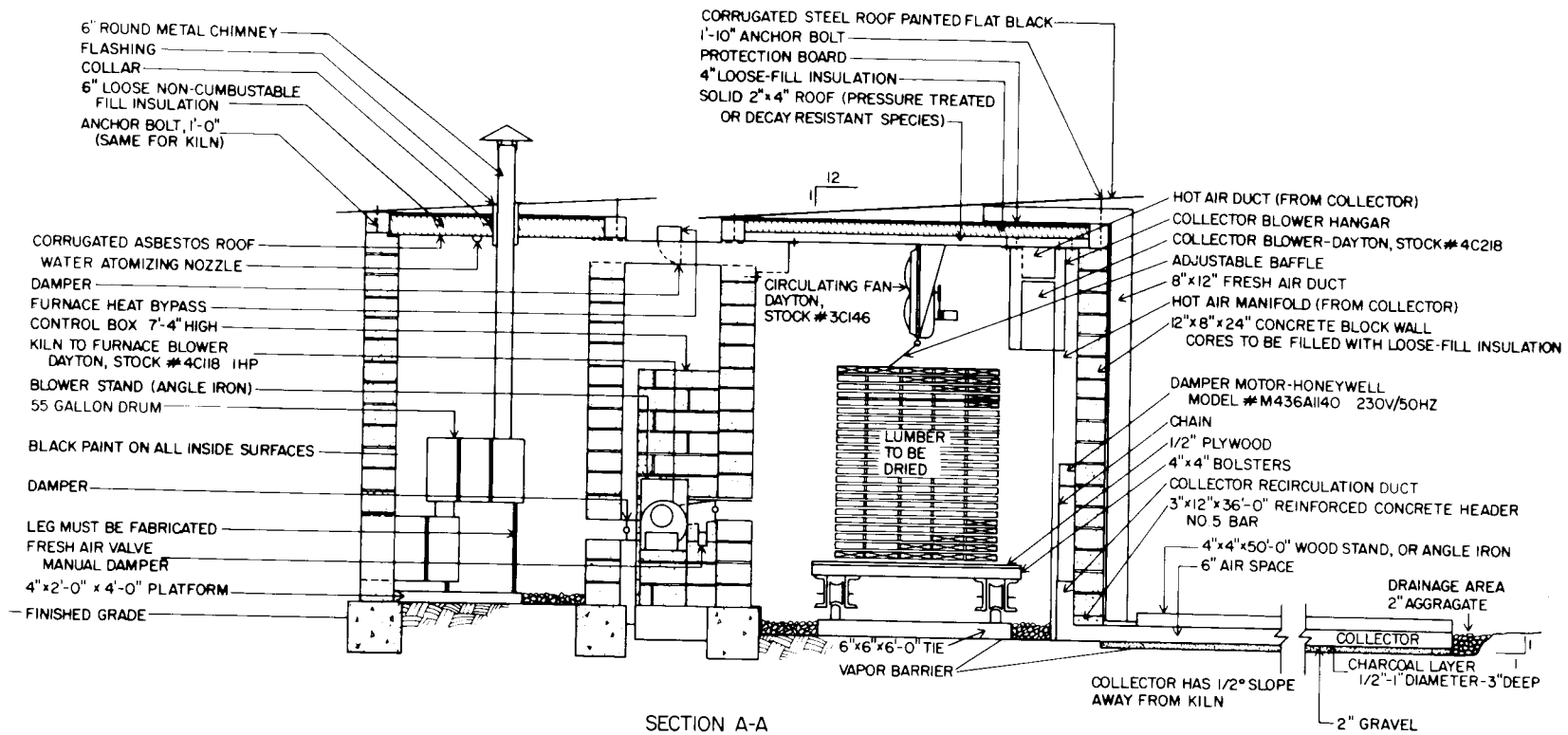

Figure A-4.—Section view of solar/wood residue kiln. (ML845652)

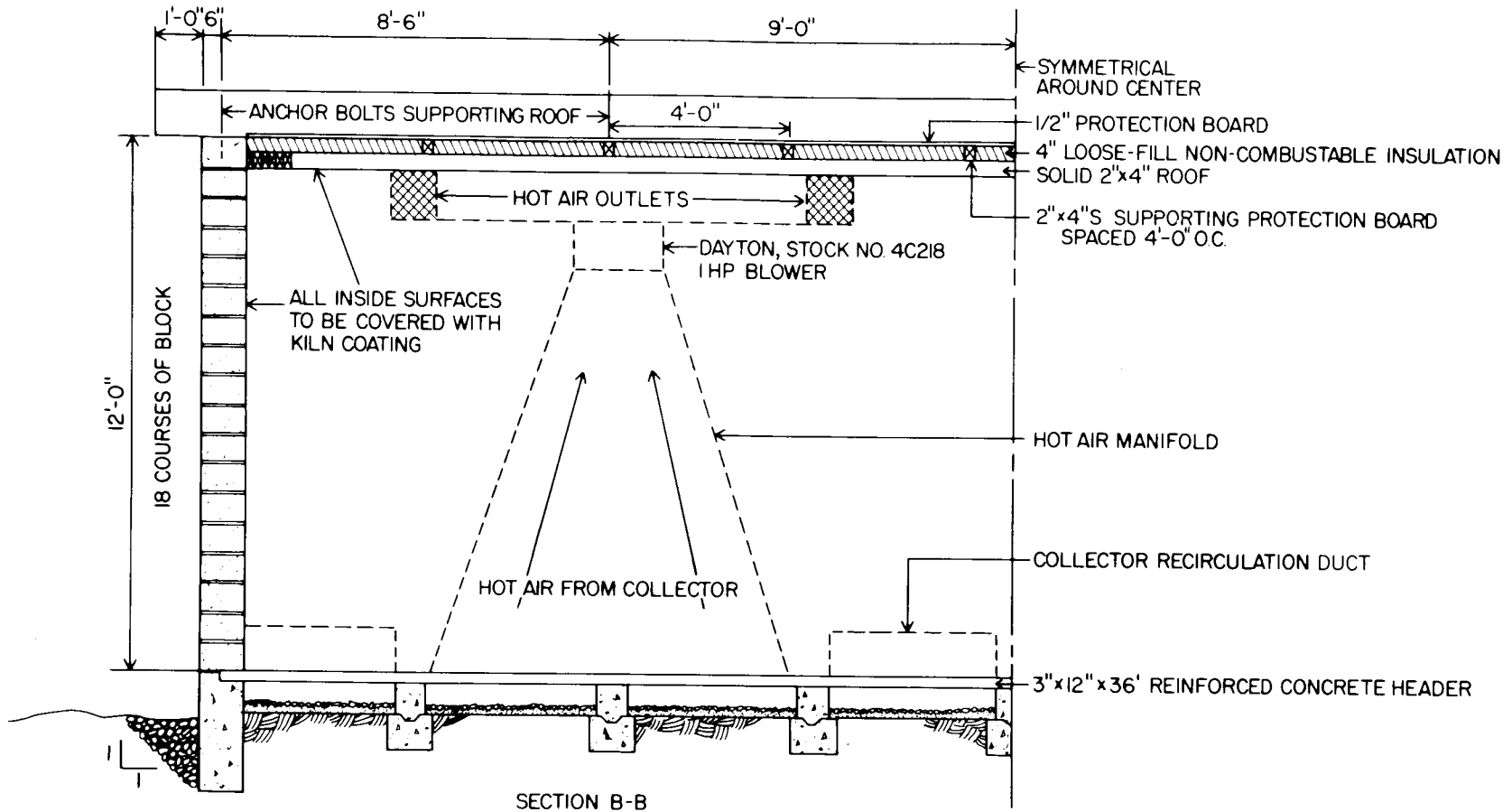

Figure A-5.—Section view of solar collector ducts. (ML845654)

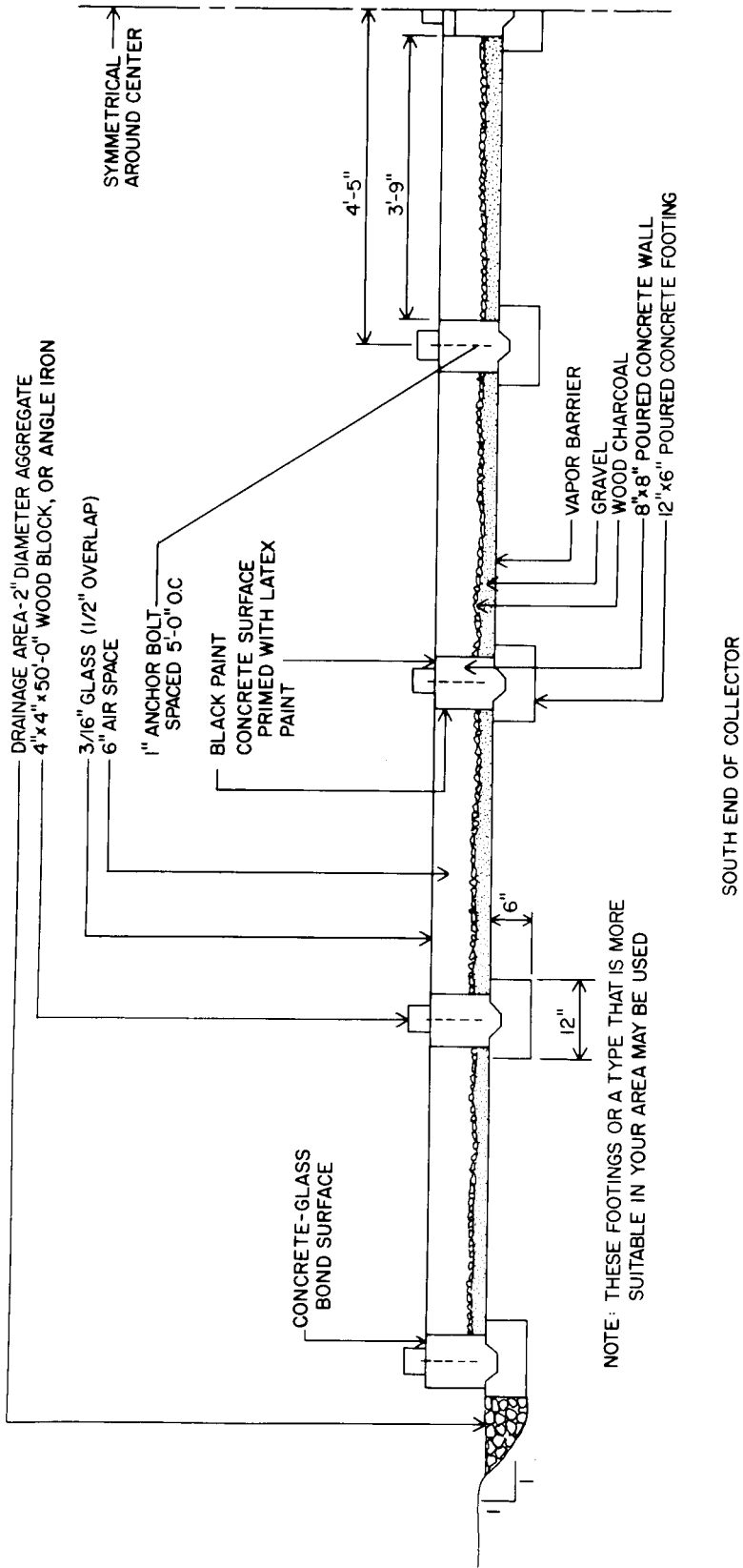
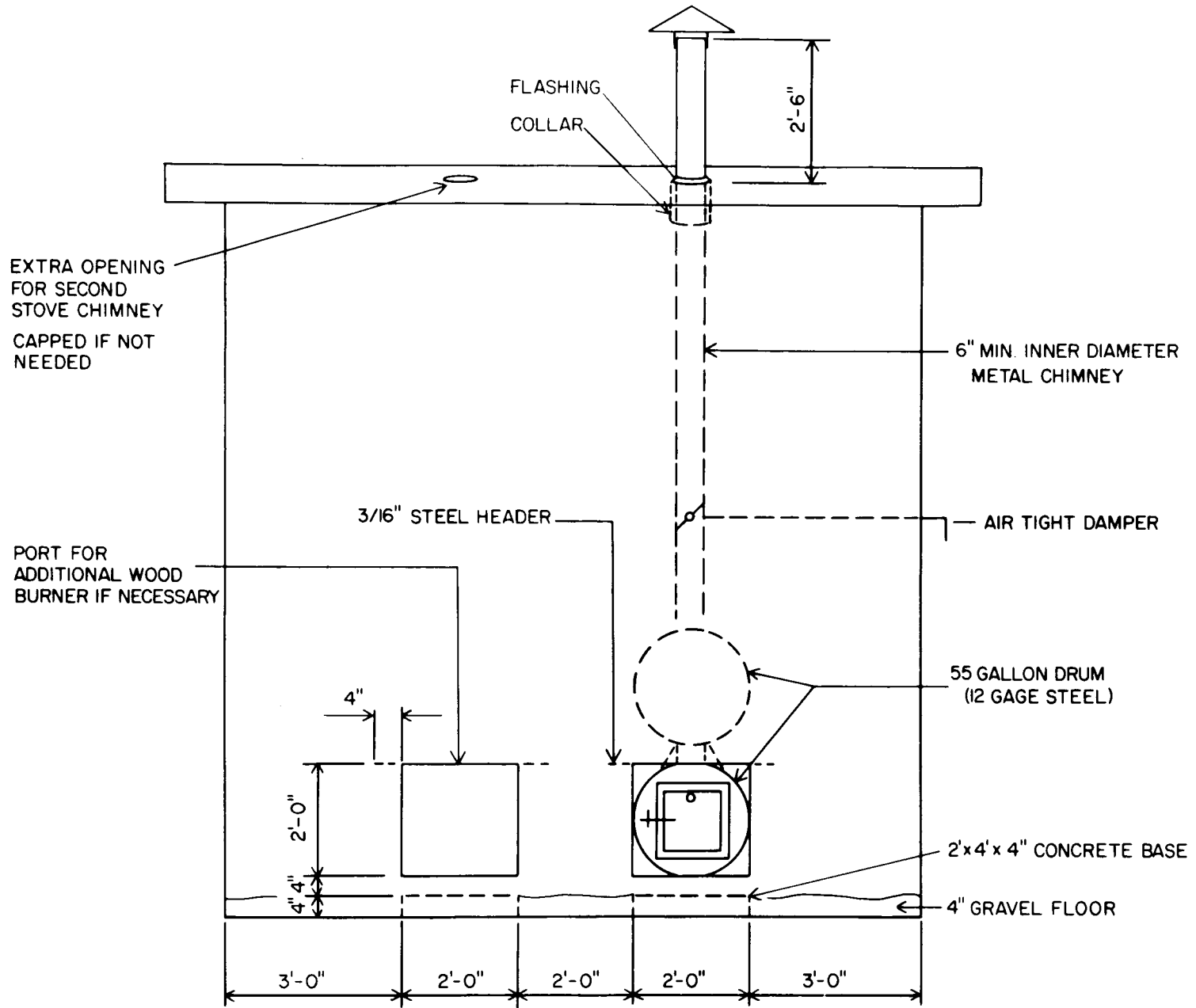

Figure A-6.—Section view of solar collector. (ML845656)



REAR ELEVATION : FURNACE ROOM

Figure A-7.—Elevation view of furnace room. (ML845655)

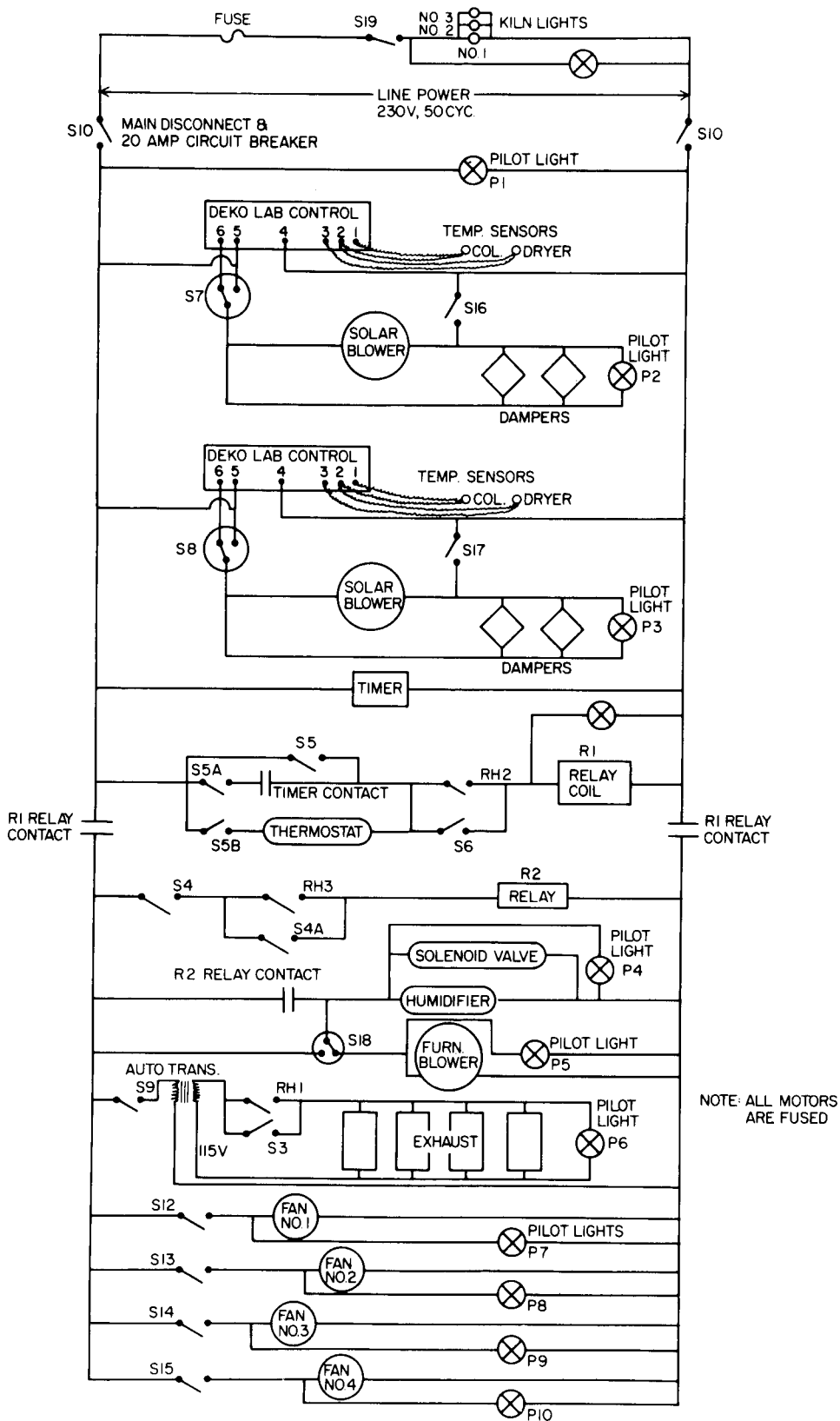

Figure A-8.— Wiring diagram of control system. (ML845650)

2.0-4/85

The Forest Products Laboratory (USDA Forest Service) has served as the national center for wood utilization research since 1910. The Laboratory, on the University of Wisconsin-Madison campus, has achieved worldwide recognition for its contribution to the knowledge and better use of wood.

Early research at the Laboratory helped establish U.S. industries that produce pulp and paper, lumber, structural beams, plywood, particleboard and wood furniture, and other wood products. Studies now in progress provide a basis for more effective management and use of our timber resource by answering critical questions on its basic characteristics and on its conversion for use in a variety of consumer applications.

Unanswered questions remain and new ones will arise because of changes in the timber resource and increased use of wood products. As we approach the 21st Century, scientists at the Forest Products Laboratory will continue to meet the challenge posed by these questions.

